

New Inventions.

Improved Mortising Machine.

The annexed engraving is part of a side elevation of a mortising machine, for which a patent was granted to Fergus Purden, of Baltimore, Md., on the 14th of last June, 1853. The nature of the improvement consists in making the bed piece in two parts so that it may be adjusted to mortises in different positions and of various widths, to allow the chips to escape from the under side of the piece mortised.

B is the post of the machine; it is represented as broken off at the top and bottom, and the improvement only is represented. D is a slide fastened to the post. F is the tool stock fitted to turn in a box, a; the upper end turns on a pivot. Gearing on the upper part of the tool stock gives it a rotary motion. The lower end of the stock, F, has a triangular socket in it to which the shanks of the drills or chisels may be fitted. For small drills and chisels a chuck is used.

The traversing bed, V, is supported and fastened in the desired position by the bolt, n, which traverses in a vertical slot in the post, B. There are two slides, p (one seen), fitted in grooves across the front of the bed, V, which are moved by two screws, q (one seen); W is a traversing bed bar; it is fastened to the slides, p, so as to be traversed on the bed, V, to adjust the divided bed in relation to the mortising cutter. The bed bar, W, is perforated by the screws, s s, which are fitted to turn freely in it. The dotted lines, t, represent pins in W, to prevent the screws, s s, from slipping endwise. These screws work in left-handed nuts in the other traversing bar, X (which lies upon the bed, V), for moving the said bar, and to adjust it as the width of the mortise requires, so that the bed pieces, W and X, support the sides of the mortise when the chips are forced out by the cutter.

The stand, Y, is fastened to the post, B, and holds the rod, u, which may be placed as desired and fastened by the screw, v, so as to hold the stop, Z, in the required position to prevent the material mortised from being raised by the chisel or drill. The stop, Z, has a score, Z', on its under surface to allow the ends of the chips which rise above the surface of the material operated on to pass freely under the stop. The adjusting bar, w, is fastened to the slide, x, represented by dotted lines, which slide traverses in grooves in the post. It is operated by a screw, y, which is fitted to turn on plate z; it adjusts the bar, w, to bring the material to be bored or mortised, and which is set against it, in a proper position under the drill or chisel. When the slide, x, is adjusted it may be fastened by the key, x'.

The piece to be bored or mortised is placed upon the bed bars, W and X, which should be

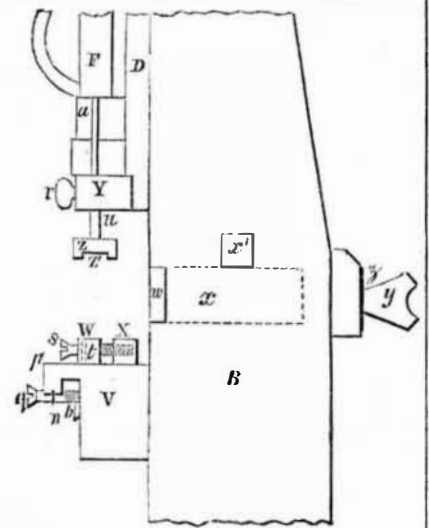

so adjusted that the drill or chisel will pass between them when it goes through the piece. The stop, Z, is set to prevent the piece from being lifted by the tool, when raised to draw it out. The score, Z', in the stop, Z, allows the ends of the chips in the mortise, which project above the surface of the piece under operation to pass freely. When the piece to be mortised is reversed, the chips come between the bars, W and X, so that they are pushed out of the

mortise, between the bars, by the chisel, in making the mortise, on the opposite side without interrupting the work or the operation of the machine.

The claim is for "the divided bed so constructed that it can be adjusted to suit the width of the mortise to be cut, to prevent the side of the mortise from being splintered by the cutter or chips, when they are forced through and driven out on the under side."

More information may be obtained by letter addressed to the patentee.

New Spoke Machine.

Andrew B. Carlin, of Allentown, Pa., has taken measures to secure a patent for an improved machine for turning spokes for carriage wheels and other like articles. The improvement consists in giving to the carriage on which the stuff is centered to be turned into spokes, an up and down motion to and from the cutters, so as to give the ovalate form to the spoke. The feeding carriage is formed in two parts connected at their outer ends by a hinged joint, the lower part is vibrated at certain times

to a greater extent, and by a separate mechanical device, than the upper, for the purpose of making greater depressions in the article to be turned, at certain points. The cutters are of a gouge shape, and revolve on an arbor; the stuff also revolves against the cutters, and a cam gives the feeding carriage its proper motion to feed the stuff so as to turn the spoke into proper form. By a different cam—which is the pattern—than that used for spokes, other articles of a different shape may be turned in this machine.

BONNELL'S FLOURING PROCESS.

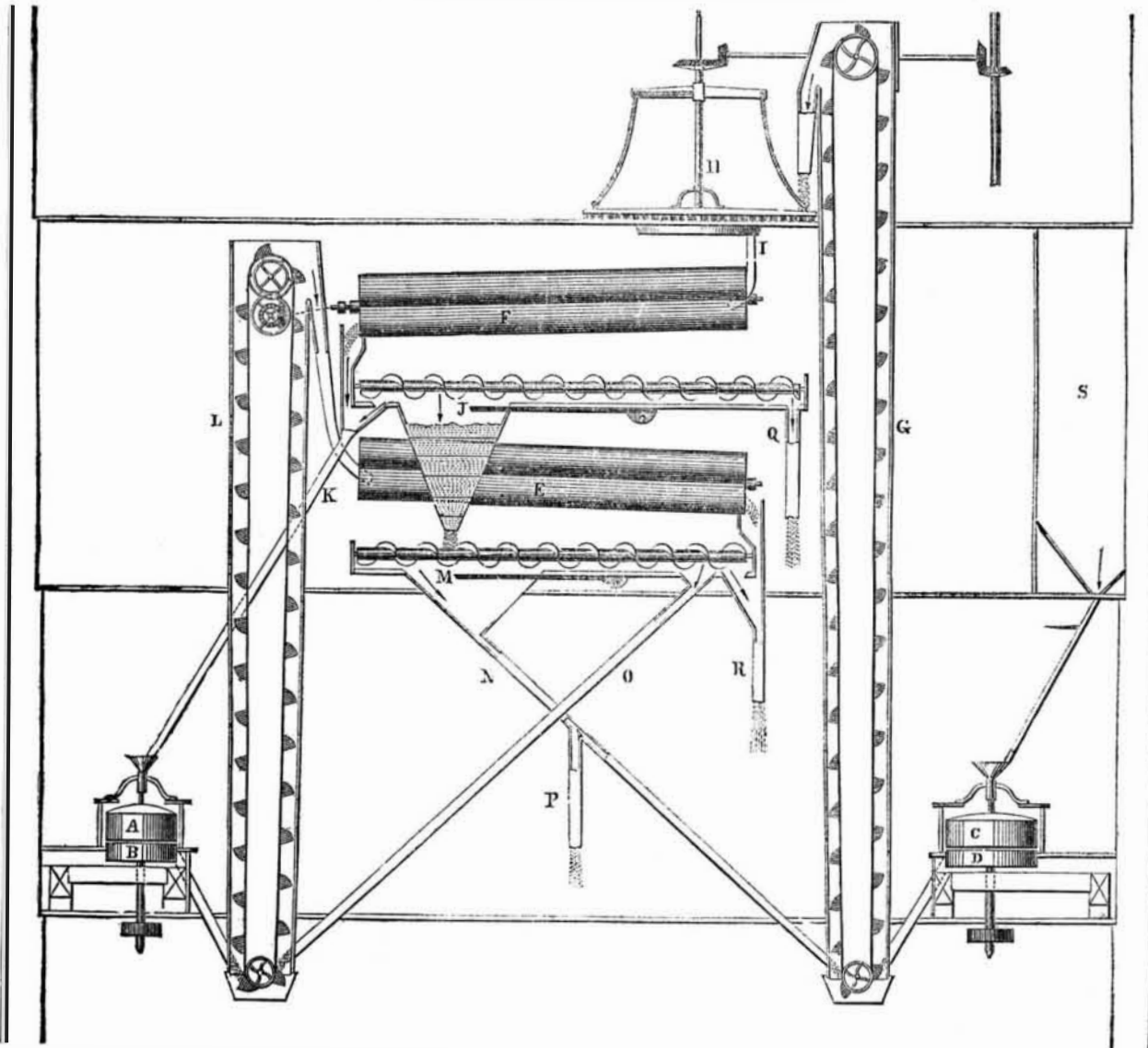

The accompanying engraving is a vertical section of a mill, which illustrates the process of flouring, for which a patent was granted to David P. Bonnell, of Indianapolis, Ind., on the 14th of August, 1849, and re-issued on the 5th of last July.

The grain is drawn from the garner, S, into the main mill stones, C D, and being ground, is carried by the elevators, G, to the hopper boy, H, and through the spout, I, to the first or superfine bolts, F, when by means of the conveyor, the superfine flour is thrown out at the spout, Q, and the returns taken off at the slide, J. The offal and specks at the tail of said bolt goes as directed by the arrows, down the spout, K, and is ground by the auxiliary mill, A B. It is then carried by the elevators, L, to the head of bolt, E, and the clear flour taken off with the conveyor at the slide, M, and sent with the returns from bolt, F, down the spout, N, and up elevators, G, to the hopper boy, H, when it is again re-bolted through the bolt, F, and incorporated with the superfine flour, or it may be taken off at the spout, P, and made into a separate article of improved Graham, or other flour, leaving that produced by the bolt, F, an extra, or double extra, article. Towards the tail of bolt, E, the returns are sent through the spout, O, to the elevator, L, and thus back to the head of bolt, E, and the bran and brown specks at the tail are discharged through the spout, R, and sent to any succeeding bolts or dusters desired, where the same rule should be observed as above, to wit:—Send the flour from the head of each bolt, back to the head of the one bolt preceding it—the middle to its own head, and the tail to the head of the next that succeeds it.

There should be a small garner over the auxiliary mill, A B, to hold a few bushels of offal, so that any irregularity of the supply from the bolts may be overcome and the stone not be permitted to run dry. The bolt cloth for this plan should generally be No. 9 and 10, except for separating the feeds, and the slides under the conveyors should move far enough to permit the miller to divide his flour and returns according to his own judgment and discretion, and a barrel of good superfine flour may be made from four bushels clean and good wheat, or a large proportion of the flour may be made into extra, with very little, if any more wheat to the barrel.

Further information may be obtained by letter addressed to M. A. Patterson, of Tecumseh, Mich., D. P. Bonnell, Indianapolis, Ind., George Arnold, of Gettysburgh, Pa., and Hiram Dodge, of West Point, Ind.

We shall publish either the full, or a well digested abstract of Mr. Bonnell's patent specification in one or two future numbers, commencing with our next; it is a very important subject.

Locomotion by Compressed Air.

Mr. J. Nickel, a correspondent of the American Journal of Science, communicates the details of a secret invention for locomotion by compressed air. He says, "the inventor, M. Julienne, believes that it will prove an economical motive power of great value. What I have seen of it satisfies me that obstacles which have till now opposed the employment of the expansive force of compressed air will disappear through the process of M. Julienne, which consists simply of

compressing air by means of a hydraulic press.

By this method M. Julienne substitutes for the solid piston, which a grain of sand may alter, which the slightest irregularity in the pump would throw out of action, and which becomes heated by friction—a liquid piston, not less incomprehensible than the other, filling always exactly the space in which it moves, be it regular or not, and acting by progression on a resistance so exactly calculated, that its proportion, although increasing, is always in relation to the force to be overcome.

The air is thus compressed at thirty atmospheres, in iron bottles, which are about four millimetres thick. It is perfectly preserved under this pressure, and it was with a bottle of this kind that M. Julienne put in action, in my presence, a small vehicle carrying two persons, and moving with great rapidity."

No man possessing a grain of engineering knowledge, would have made a statement like the above. The compressed air surely cannot give out more power than the quantity employed to compress it. Why then not apply the mechanical power employed to condense the air direct to the propulsion of machinery, instead of uselessly employing expensive machinery to apply it second hand. It reminds us of that wisdom displayed in two or three places that we might mention, in the employment of a steam engine for pumping water up a height to drive a water wheel.

The Flax Cotton Factory, at Cohoes, N. Y., was destroyed by fire last week. The flax cotton was used in the factory, along with cotton and wool, in the manufacture of knit fabrics.