

Scientific American.

THE ADVOCATE OF INDUSTRY, AND JOURNAL OF SCIENTIFIC, MECHANICAL AND OTHER IMPROVEMENTS.

VOLUME VIII.]

NEW-YORK, JUNE 4, 1853.

[NUMBER 38.

THE Scientific American,

PUBLISHED WEEKLY

At 128 Fulton street, N. Y., (Sun Buildings),

BY MUNN & COMPANY.

Hutchins & Co., Boston.
Dexter & Bro., New York City.
Stokes & Bro., Philadelphia.
LeCount & Strong, San Francisco, Cal
Cooke, Kinney & Co., ditto.
B. Dawson, Montreal, C. E.
M. Boullemet, Mobile, Ala.
E. W. Wiley, New Orleans, La.
E. G. Fuller, Halifax, N. S.
M. M. Gardissal & Co., Paris.

Responsible Agents may also be found in all the principal cities and towns in the United States.
Terms—\$2 a-year—\$1 in advance and the remainder in 6 months.

USEFUL RECEIPTS.

Hair Waters.

A very fashionable liquid, now in such prevalent use for removing the dandruff from the hair, is made by mixing together bay rum 4 quarts; water 1 pint; glycerin 2 ozs.; tinct. cantharides $\frac{1}{2}$ oz.; carb. ammonia $\frac{1}{2}$ oz.; borax 1 oz.

Dissolve the two last in the water and add the solution to the other materials mixed together, and then shake up well.

The hair is moistened with this liquid, and the slight lather occasioned by rubbing with the hands must be washed out with water.

By doubling the quantity of borax, the lather is more soapy, but the addition is injurious to the hair.

By omitting the borax, a wash is obtained nearly identical with the far famed "Balm of Columbia," and similar cosmetics for the hair.

Hair Tonic.

Black tea 2 ozs.; water 1 gallon; bay rum 1 quart; glycerin 3 ozs.; tinct. cantharides, 1 oz.

Exhaust the tea with the water heated to boiling, filter, and stir in the remaining ingredients previously mixed.—[Ex.

[The cantharides should never be used; they injure the hair far more than the borax; they were first employed by the French perfumers. Some honey added to either of these hair waters greatly improves their quality for thickening the growth of the hair.

Cherries Without Stones.

Cherries without stones have been produced in France, it is said, by the following method:—In the spring, before the circulation of the sap, a young seedling cherry tree is split from the upper extremity down to the fork of its roots; then, by means of a piece of wood in the form of a spatula, the pith is carefully removed from the tree, in such a manner as to avoid any excoriations or other injury; a knife is used only for commencing the split. Afterwards the two sections are brought together, and tied with woolen, care being taken to close hermetically with clay the whole length of the cleft. The sap soon re-unites the separated portions of the tree, and, two years afterwards, cherries are produced of the usual appearance, but, instead of stones, there will only be small soft pellicles.

A Musical Peddling Dentist.

One M. Duchesne has been driving about Paris in a gaudy wagon and with a band of music, taking out teeth. He stops in some frequented place, collects a crowd by means of the cymbal, and then invites the afflicted to apply at once for extraction and relief. A notice on the side of the wagon reads thus:—"5,000 francs if I miss a tooth." Each applicant mounts on the seat with M. Duchesne, who demands the coin before proceeding.—The head is then inclined backwards, the mouth opened, the tweezers inserted, and the tooth snatched from its gory bed. It is held up in the air an instant for the admiration of the multitude, and at each extraction the drum gives a bang of triumph.

WILSON'S IMPROVED PATENT SEWING MACHINE.—Figure 1.

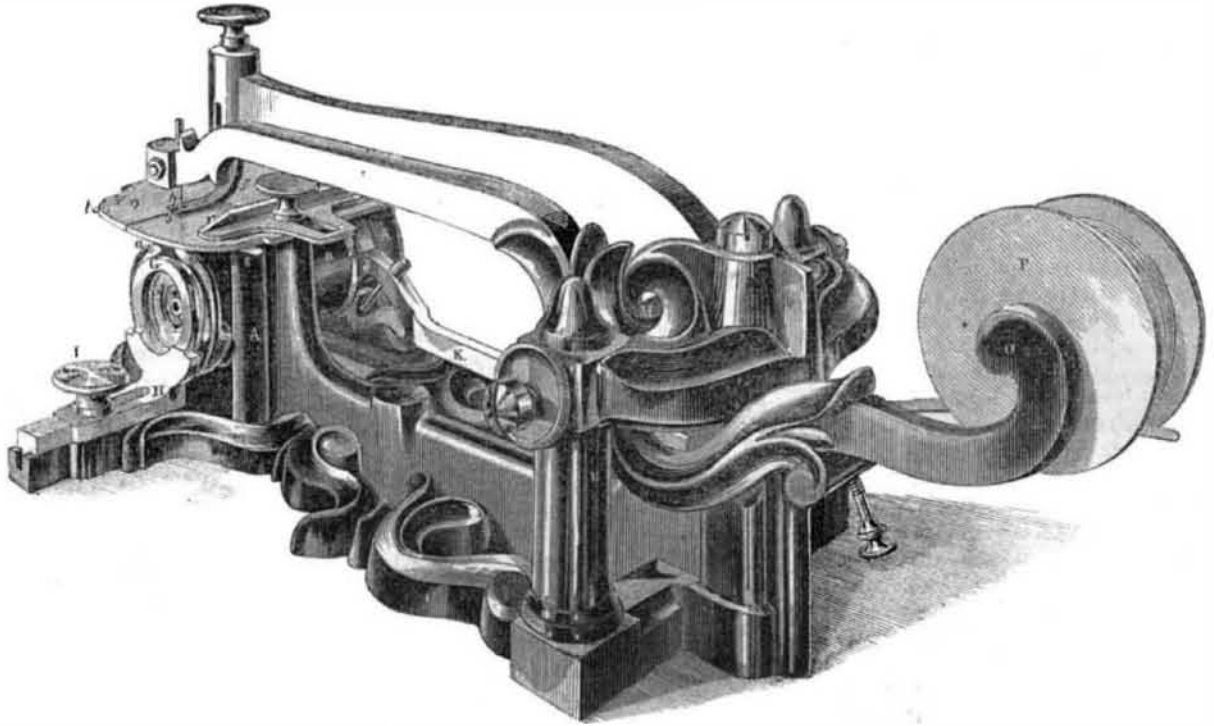

The annexed engravings are views of the celebrated Sewing Machine invented by A. B. Wilson, of the firm of Wheeler, Wilson, & Co., and for which a patent was granted on the 15th of last June (1852). Mr. Wilson had invented and received patents for previous sewing machines, one of which has been described in our columns, but this one appears to be the very perfection of sewing machines.

Figure 1 is a perspective view; figure 2 is an end elevation of the same; figure 3 is a transverse vertical section of the same; figure

4 is a view in perspective of the rotating hook which opens the loops; figure 5 is a view in perspective of the cymbal spool which carries the thread; figure 6 is a perspective view of the feed bar and appendages attached from the machine. The same letters refer to like parts.

The machine is a peculiar one and works with two threads, and forms the firm lock stitch, but it has no shuttle and has but one needle. The working parts are secured to a neat small frame, A B, and when in operation

and the notch, *c*, between the portions of the screw threads is made to extend back from the hook, *a*, about one-third of the circumference. Within the concavity in the face of the hook, plate, *F*, there is a hollow quilt-formed bobbin, *F*, which carries a thread to be passed through the loop formed by the needle thread when it has passed through the cloth, so as to form the lock or true binding stitch. This peculiar bobbin is held by a ring, *G*, attached to a rod, *H*, which is adjusted by a screw, *I*, secured in the frame; this ring keeps the bobbin in its place, but allows it to turn freely. One part, *d*, of the mandrel is turned eccentrically and is encircled by a ring, *J*, to which a rod, *K*, is attached, which connects to an arm, *L*, and is secured to the arbor, *M*, which is fitted in bearings in the standards, *B B*, of the frame, and forms the fulcrum of a two-armed lever, one of whose arms, *N*, is the needle arm, and to the other, *O*, is secured the spindle, upon which is hung the spool or bobbin, *P*, which carries the thread for supplying the needle and forming the loops. By the revolution of the mandrel, *C*, the eccentric, *d*, is caused to give a vibratory movement to the lever, *N O*.

The cloth or material to be sewn is laid upon a plate, *Q*, which is secured to the top of the standards, *A A*, and forms a small table. It is held down by a small pressing plate, *f*, which is attached to the end of an arm, *R*, secured to the back of the standards, *B B*, and extending over the top of the needle to pass through, and an opening corresponding to the notch, *g*, is cut through the plate, *Q*, for the same purpose; *N* is the vibrating arm which carries and works the needle, *h*; the hook, *a*, rotates and passes as close as possible in front of the needle; the movements of the hook and needle are so regulated that the hook passes the needle just as the latter is commencing its ascent. The cloth is fed forward to the needle by means of a peculiar feed bar, *S* (fig. 6). This bar is straight and flat with a slot nearly its whole length, and with two ears, *i i*, on its under side; under the slot is secured a spring bar, *k*, which has a pointed tooth, *l*, at the end. The bar, *S*, slides in mortices in the standards, *A*, below the plate, *Q*. The point of tooth, *l*, is below the small slot in plate, *Q*, and passes through it, catching the cloth and moving it forward a short distance for a stitch, then rapping down to take another stitch. This

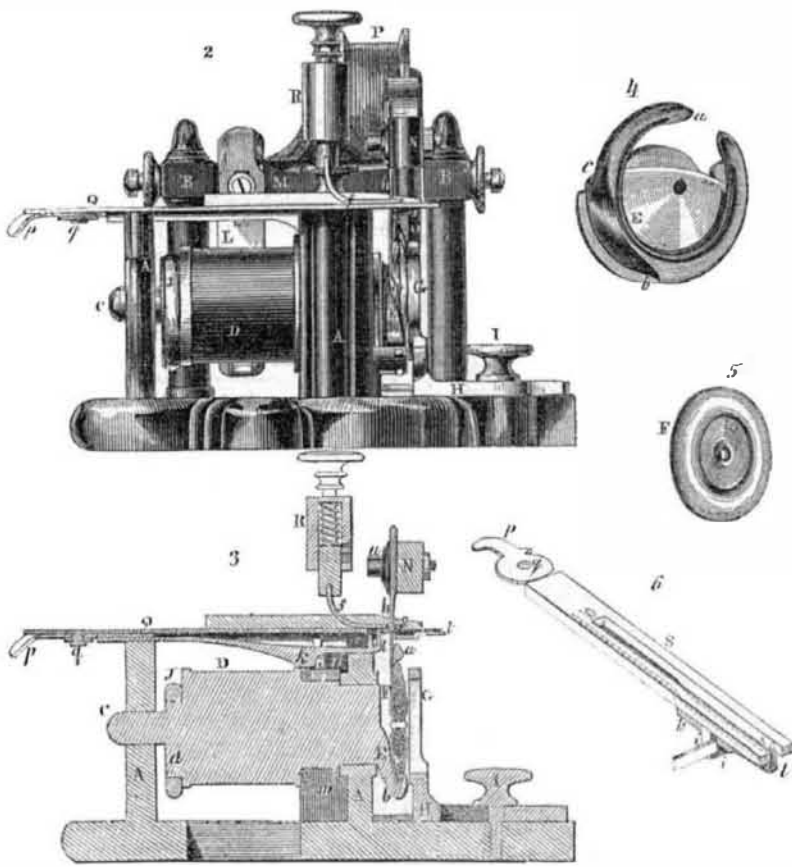

is placed on a small table before the operator and is driven by a stirrup band and pulley, like a foot lathe, or it can be driven by steam or water power with band and pulley; *C* is a mandrel, and *D* a pulley on it to receive motion by a band as described. At the front, end of the mandrel, *C*, there is a rotating cam plate hook, *E*, (best seen in figure 4) on

it; this rotating cam hook is of a peculiar form; it is concave on its face, and has portions of two threads of a screw formed on its periphery, a portion of the periphery is also cut away to form the hook, *a*, which opens the loop in the needle thread. One part of the front or outer thread of the screw is chamfered off at *b*, to the back or inner thread,