

## SLOAN'S PATENT HYDROSTAT FOR STEAM BOILERS.

Figure 1.

Figure 2.

Figure 3.

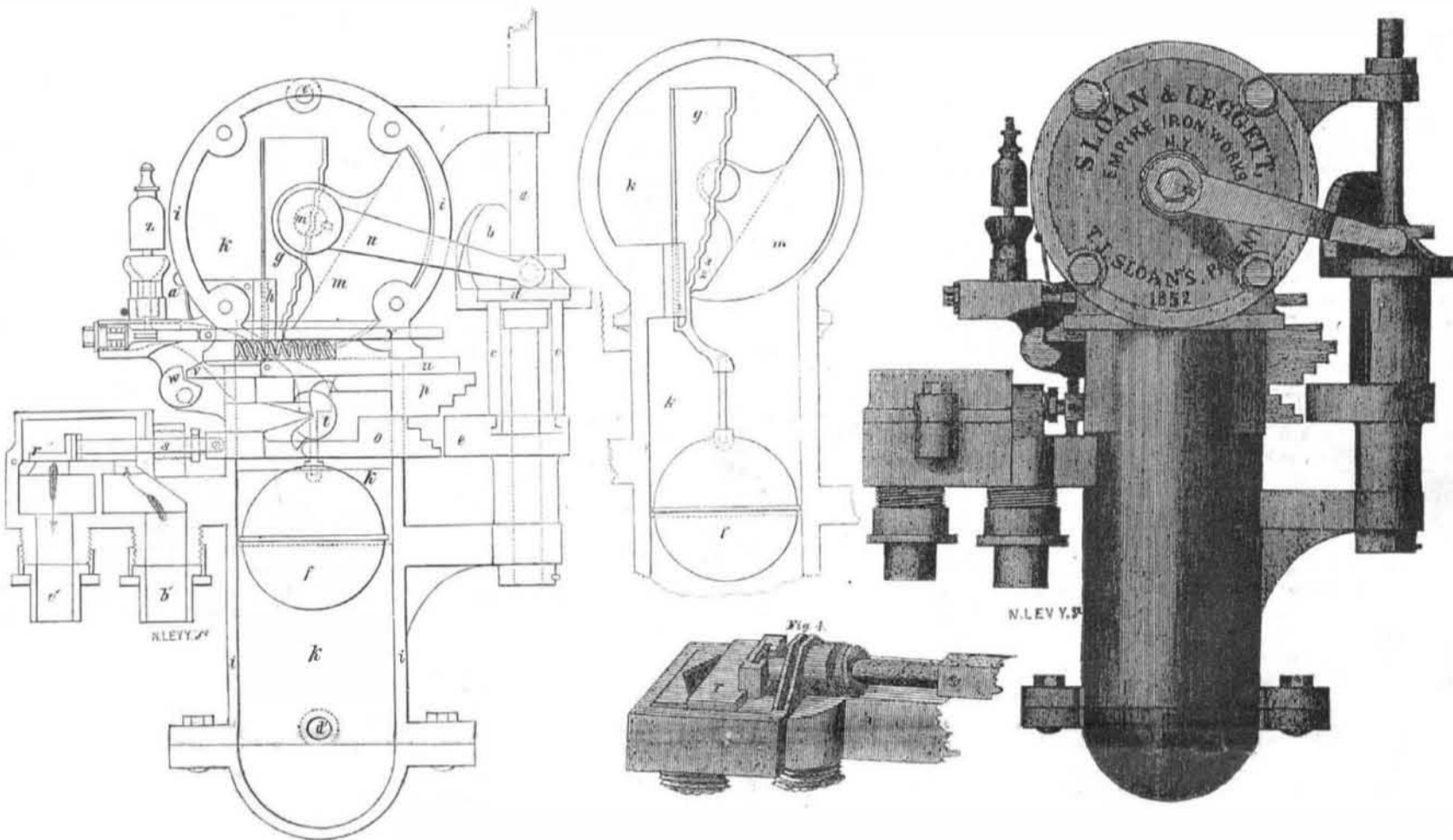

The above are engravings of the 'Hydrostat' for the prevention of steam boiler explosions, invented and patented by T. J. Sloan, of this city, N. Y., last year, and noticed by us in our remarks about inventions exhibited at the last Fair of the American Institute.

Figure 1 is a vertical section of the apparatus; figure 2 is a vertical section of the float and notched arm in the hot water chamber; figure 3 is an outside view of the apparatus, and figure 4 is a perspective view of the slide valve with its cover removed. The same letters refer to like parts.

The hydrostat is designed to keep the water in the boiler always at the same level or near the water line, which is done by interposing a regulating valve, between the feed pump and the boiler, the said valve being regulated by a float which indicates the height of water in the boiler, but which is operated by the engine, and thus no mechanical labor is entailed upon the float, to make it work incorrecly, but it is left free and easy of motion by the rise and fall of water in the boiler, so as to make it always indicate the water-line correctly.

The hydrostat illustrated is connected to the boiler by two tubes behind; *a* is a vertical spindle which receives a continual rotary motion from a shaft above, coming from the engine. On this spindle is a revolving cam, which forms an outside collar surrounding a grooved collar and sleeve, *d*; which move up and down every revolution of the spindle in curved slits, *c c*; on the cam collar, *e*, is another cam like, *b*, but is attached to the sleeve of collar, *d*, and not to spindle, *a*; *f* is a copper float to which is attached a composition metal arm or indicator, *g*, having a flange on either side, serving as a guide in its passage loosely through the slotted rest, *h*, fastened on the inside of the case, *i i i*, which forms the steam chamber and water reservoir, *k k k*, with its water and

steam connections, *d'* and *e'*. The dotted line across the float, *f*, shows the water-level, with the float resting on the surface, holding the indicator, *g*, with the lowest grade or step opposite the edge of the weight, *m*, figs. 1 and 2. A shaft, forming part of the weight, *m*, passes through a stuffing-box in the outside of the front plate enclosing the steam chamber, *k*; keyed firmly to this shaft is an arm or lever, *n*, with a pin in the other end resting on the cam, *b*, and entering the groove of the collar, *d*; when the shaft, *a* revolves, the cam, *b*, coming in contact with the pin raises it to the highest point of the cam, *b*, thereby, also, lifting the grooved collar, *d*, which carries the slides, *c c*, and the cam, *e*, also relieving the indicator, *g*, from the pressure of the weight, *m*, allowing it to assume the positions which the float determines by resting on the water; the cam, *b*, still moving, allows the arm, *n*, and grooved collar, *d*, to fall gently, until the edge of the weight, *m*, again touches one of the steps of the indicator, thus making the position of the cam, *e*, dependent upon the elevation or depression of the float. The notched slides, *o*, and *p*, are fitted so as to play freely in a chamber cast through the instrument, so that the slides, *o* and *p*, do not come in contact with the steam; these slides are so connected with the supply valve, *r*, controlling the connection between the two parts of the feed-pipe *b'* and *c'*; that when, *p*, is pushed in by the cam, *e*, the valve is opened, and when, *o*, is pushed in, the valve is closed, and the slides are so attached by the piece, *t*, on a wedge centre, that one slide comes out in proportion as the other is pushed in, and vice versa. The water in the engraving is represented as high; we will suppose it commences to fall; at each succeeding revolution of the shaft, *a*, the weight, *m*, will rest on a higher notch or step of the indicator, *g*, causing the cam, *e*, to rise accordingly, which will successively press in the slide, *p*,

until the supply-valve, *r*, is wide open, when, if the water still continues to fall, the cam, *e*, is raised still higher, and, in its revolutions will press in the slide, *u*, which, by means of the fall, *v*, and hub, *w*, causes the hammer, *a'*, to strike the bell on the back part of the instrument, thereby giving the first alarm to the engineer that the pumps are not feeding or the water is shut off; and if he cannot remedy the difficulty, and the water continues falling, the cam, *e*, is elevated still further, so that it presses in the stem, *y*, which opens the puppet-valve and admits the steam to the whistle *z*, which sounds the general alarm, notifying the engineer and others that the water in the boilers is getting too low for safety. If the supply begins to be restored again, the float rises, and the parts assume their original position.

The feed water to the boiler must pass through the instrument coming in by pipe, *b'*, and out to the boiler by pipe, *c'* when the valve, *r*, is open, and the notched slides, *o p*, operate one another, so that when one is pushed in the other is thrust out; it is thus that the valve, *r*, is self acting. This instrument being continually in motion, it cannot become useless from neglect. Should the stuffing-box at *m*, be too tightly packed, or it from any cause the parts do not work freely, the arm lever, *n*, will remain at the top of its stroke, holding up the sleeve and collar, *d*, by which the cam, *e*, will be made to strike the slide, *u*, as the said cam revolves, and thus strike the pin, *v*, and give the alarm spoken of. The arm, lever, *n*, is operated in the same way, by dropping down as the water falls low as indicated by the sinking of the float, *f*. The notches, 2 3, as shown in figure 2, of the indicator, *g*, are so represented that the action of the weight, *m*, on the said indicator is clearly seen, so as to show how the arm, *n*, figure 1, works the collar, *d*, and cam, *e*, which operates the slides of the valve, and

likewise the bell and whistle pins.

This beautiful, useful, and ingenious apparatus is manufactured by Messrs. Sloan & Leggett, the proprietors and manufacturers, at the Empire Iron Works, foot of East 25th street, this city.

In our opinion, it tends greatly to the safety of every steam boiler on which it is placed, and is the most unique instrument as a boiler gauge, regulator of feed water and alarm, that has yet been invented.

### Aerial Navigation again.

By the Washington papers we learn that Prof. Porter has been astonishing the dwellers in that goodly city with his wonderful Aeroport, 20 feet long, and filled with hydrogen gas—the lightest of all the known elements of matter.

"The float was filled with hydrogen gas; from it was suspended a saloon, containing a steam engine to move the screw propellers, which operate between the float and the saloon. The Aeroport moved gracefully around the room to the great delight of the spectators. So far as this experiment is concerned it was successful."

We are not informed of the size of the steam engine; it was no doubt as big as a piece of chalk, therefore, according to the small amount of evidence, which is required by so many paragraphists, we have now a demonstrated fact of aerial steam navigation being perfectly successful. We have no such hope, because we have no faith in this project,—some new discovery must be made before that can be accomplished. Prof. P., however, is a wonderful wizard in conjuring up new inventions to contend for victory with the "Prince of the Power of the Air."

A Boston firm has just cut 5,000 tons of ice on Winnipissogee Lake. Its cost will be \$2 per ton at Long Wharf, the firm will get at least \$25,000.