

## NEW INVENTIONS.

## Felloe Machine.

John Sitton, of Columbus, Miss., has taken measures to secure a patent for the above. This machine, which the inventor denominates the "Wheelwright's Assistant," is intended to perform the various operations of boring the hub, forming the tenons and shoulders of the spokes, and also *holing* the felloes. An important improvement is in the use of two circular plates, one lying on the other, and capable of revolving. These plates serve for regulating the distances between the spokes, as the top one carries the hub while being bored, and the wheel when the tenons are being cut. This arrangement, when fixed for boring, &c., is held in position by pins acted on by springs. The auger carriage moves back and forth on an adjustable way or bed, which can be fixed to suit different-sized wheels, the carriage is made to advance by means of a cord and weight, and is drawn rapidly back by operating a treadle. The tool for cutting the tenons and shoulders of the spokes is of a peculiar shape, and acts more perfectly than other tools, both for cutting and also regulating the depth of the tenons and also for squaring the shoulders. An adjustable bench for boring the felloes upon, can be attached or removed as required, this is furnished with an arrangement for holding the latter, and is so contrived that the bench need not be shifted when the end of the felloe is to be bored, but merely a movable pin. In addition to all these improvements there is a neat mode of regulating the size of the wheels by an index plate properly fixed.

## Auger Handle.

An improved Auger Handle has been lately invented by Willis Churchill, of Hamden, New Haven Co., Ct., who has taken measures to secure a patent. The advantages of this handle are, that the auger can be very quickly taken out without much trouble, and a smaller auger be substituted, which is tightened in its place by a rapid turn given to a part of the handle. It is, moreover, much stronger than in the case of those made by the ordinary arrangement. Its principle consists in forming the handle in two parts, each having a screwed rod, on which works a cylindrical nut: one of these nuts has two eye-pieces cast on it, and the other has one similar eye-piece. When the auger is to be fixed, the two parts of the handle are placed together and the tool inserted in the socket. It consequently passes through the three eye-pieces which are so arranged that the single eye lies between the two which are on the other nut, hence both parts of the handle are held together by the stock of the auger being passed through the three eyes. But if the stock be not sufficiently tight, it is only necessary to turn one half of the handle, when its nut will be moved along the screwed rod, and drawing its eye-piece with it, will cause the auger to be firmly held.

## Improved Windmill.

Measures to secure a patent for an improvement in Windmills have been taken by A. Osborn, of Albany, N. Y. This improvement is intended to facilitate the construction of the wings or sails so as to give them the proper curve. Practice has proved that the wings, where they join the centre or hub, should have an angle of about 20°, and the outer ends of the wings an angle of about 7°, a gradual curve following the length of the wings. The inventor obtains the desired form by using two circular rods, which are placed one on each side of the sails or wings, and near their outer edges; these rods are connected by clamps or adjustable screws, so as to be brought nearer to each other, as required. These rods also serve as a fly or balance to the wings.

## Carriage Spindle.

The common heavy cast-iron sleeves, which are much used for axles, are exceedingly clumsy, so that many prefer to use the wooden axle alone, while others are made entirely of iron. A contrivance to obviate this defect has been made by Thomas Mills, of Clearfield, Pa., who has taken measures to secure a patent. The invention is intended to introduce the use of a sleeve or tube made of light wrought-iron plate, which gradually tapers so as to fit on

the tapering end of the spindle to which it is bolted. A shoulder collar, with two straps, fits tightly on this sleeve, and serves also as a shoulder for the axle to which it is secured by a screw bolt and nut. This arrangement materially strengthens and braces the spindle. The sleeve is made by cutting a thin piece of

boiler plate to the proper size and shape, and then, after heating it, passing the plate between three tapering rollers, one of which is adjustable. The edges of the tube are afterwards brazed together, a couple of rings being employed to secure it from opening during the process.

## IMPROVEMENT IN PIPE MOULDING.

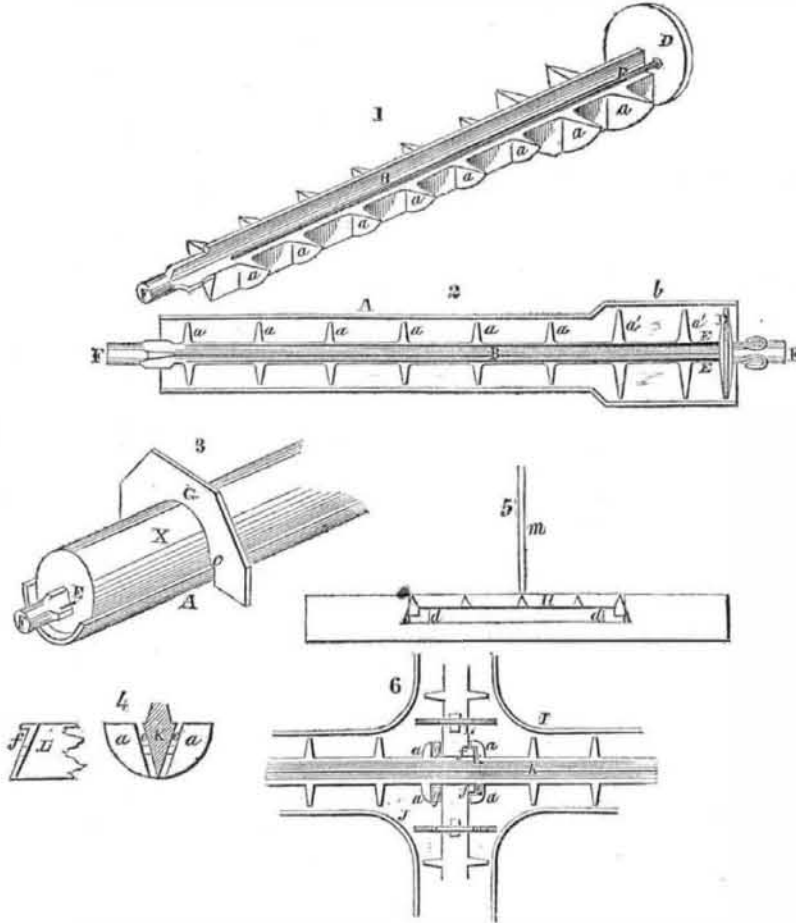

The annexed engravings are views of a valuable improvement in the moulding of cast-iron tubes, invented by George Peacock, of West Troy, Albany Co., N. Y., who has taken measures to secure a patent for it.

Figure 1 is a perspective view; fig. 2 is a plan view of the core-bar placed in a core-box; figure 3 is a perspective view of the core, showing the manner in which the upper half of the core is rounded or finished by the sweep; fig. 4 are sections showing the manner in which the core bars are jointed, or connected, in order to form cores for branch pipes, elbows, &c. Fig. 5 shows the manner in which the core-bar is anchored or prevented from being raised by the melted metal. Fig. 6 is a plan view of two core-boxes, intersecting each other, with the core bars placed in them and jointed. This view shows how cores may be formed with facility for elbows, branch-pipes, &c. The same letters refer to like parts.

A, in figs. 2 and 3, is a core-box, which is merely the half of a pipe cut longitudinally through its centre, and which serves in the place of an ordinary pattern. B, fig. 1 and 2, is the core-bar, formed of a lozenge-shaped bar, having a series of semicircular wings or projections, *a*, on its lower half; D D are collars, one only is seen in figures 1 and 2; these collars are placed on the core-bar, one at each end, and turned to fit the core-box, A, or to be of the size required for the pipe intended to be cast; E E are vent-rods, which rest upon the upper surfaces of the wings and on each side of the bar. F F are cylindrical handles, by which the core-bar is lifted when necessary. The core-box, A, is of the size and form of the pipe intended to be cast; it is properly adjusted in the sand, and the core-bar placed in it, as shown in fig. 2; the core-bar corresponds in shape to the core-box; that is, any portions of the pipe that are larger in diameter than another, are opposite proportionably larger wings (see the end, *b*, of the core-box and wings, *a*, fig. 2). The core-bar being adjusted or placed within the core-box, green sand is packed or pressed all around the lower half of the core-bar, and between the wings, *a*, thus forming a perfect half cylinder of sand on the lower half of the core-

bar. This being accomplished, the upper part or surface of the core-bar is covered with green sand and piled up till it reaches a necessary height. A sweep or gauge, G, fig. 3, of a semicircular shape, is then drawn over the sand and the upper part of the core-bar, X, to remove the surplus sand, as shown in figure 3. The sweep, G, has small shoulders, *c*, which rest upon the upper edges of the core-box, and serve as guides. The larger portion of the core, which fits the part, *b*, of the core-box, is rounded by a larger sweep than G. The core being now formed, the vent rods, E E, are withdrawn, whereby vent holes are left in the core for the escape of gas and steam, while the molten metal is being poured into the mould. The core is lifted or raised from the core-box by the handles, F F, the wings, *a*, binding and holding the sand to the lower part of the core. The core is then adjusted in the mould (the core-box being removed), the collars, D, on the ends of the core-bar resting on the ends of the flask. Any length of pipe may be cast in this way, for the core may be anchored and prevented from raising, by means of metal strips or bridges, H; one is represented in fig. 5. These strips or bridges fit in recesses cut in the upper part of the core bar, and rest upon wooden supports, *d d*. An anchor or rod, *m*, rests or bears upon the upper part of the bridge; the opposite end of the anchor being secured to some permanent support. When the liquid metal is poured into the mould, the anchors prevent the metal from forcing up the core. After a certain time the wooden supports, *d d*, burn out, and the strip or bridge will fall in the recess, and the anchor may be withdrawn, also the core. Any number of these bridges, according to the length of the pipe, may be employed. The upper part of the core is not quite as high or deep, as the lower portion to which the wings are attached. This is for the purpose of allowing the core to be easily withdrawn from the pipe after it is cast.

The core-bar, in common use, is formed of a hollow cylinder covered with small projections; it is placed on a pair of tressels, and the sand is pressed upon it. A second person then revolves or turns the bar, and the superfluous sand is taken off by a gauge similar to

a rest for a lathe. This is a slow and uncertain process, and can only be applied for the casting of short pipe. Any length of pipe may be cast by forming the core in the new mode represented, and the pipe may be of any desired thickness. The pipes cast by this process will sustain a pressure of 500 lbs. Any kind of pipe, lamp-posts and bridge tubing may be made in this manner. The wings, *a*, may vary in shape according to the form of the article to be cast. For round pipes the wings are made semi-circular; for hexagon, the wings half hexagon, &c. For elbows and branch pipes, the core-bars are jointed, as shown in figs. 4 and 6. Suppose I to be the main pipe, and J a branch pipe intersecting the main pipe at right angles (I and J we also call core-boxes), K is the core-bar of the main core-box, I, and L is the core-bar of the branch core-box, J. The core-bar, L, is jointed to the core-bar, K, as follows:—The bar, L, is composed of two parts, and one end of each part is connected at opposite sides of the bar, K; the two parts of the bar, L, being in line. The end of each part of the bar, L, fits between two wings, *a a*, on bar K, and a recess, *e*, is made in the inner side of one of the wings in which the projection, *f*, of corresponding size on the side of bar L, and at its end, fits. This projection is secured in the recess *e*, by means of a wooden wedge, *g*, which is driven tightly between the bar, L, and the adjoining wings. When the core is formed and adjusted in the mould, the molten metal burns out the wedges, and the core-bars become detached from one another, and may be readily withdrawn. The core bar, so constructed and applied, the anchoring of it, whereby the wooden supports are burned out by the molten metal to allow the core to be withdrawn; also the manner of jointing the core-bars for making elbows and branch pipes, as described, are the leading and important features of this improvement.

More information may be obtained by letter addressed to Mr. Peacock.

## Cotton Topping Machine.

Measures to secure a patent for an improved machine of the above description have been taken by A. A. Dickson, of Griffin, Ga. This machine will perform the work of topping the cotton and lopping off the ends which bend over the rows in a most perfect manner. It can be made cheap and light, and one man suffices to work it. The principal part of the framing is formed similar to a wheel-barrow, and the wheel which serves to propel it also communicates motion to the cutting apparatus by means of two bands or belts running over small pulleys formed on the sides of the propelling wheel. Two sets of cutters are employed, one for topping and the other for lopping off the ends of branches. The latter operation is performed by cutters that are placed vertically on a horizontal shaft; the topping is effected by horizontal cutters on a vertical shaft. These latter are made adjustable so that they can be arranged to suit the different heights of the cotton plant, and also the different widths of the rows.

## Improved Cement.

A new and useful composition for covering roofs of buildings, &c., has been invented by Thomas Scholey, of Peoria, Ill., who has taken measures to secure a patent. It is also applicable as a coating for pipes or for covering walls, &c., and possesses many advantages that render it superior to other cements. Some of these latter, particularly those applied to roofing, are liable to crack in cold and to get soft in warm weather, neither of which evils occurs in the above-named composition. This new cement is hard, so that it can be polished to any extent, but from the nature of the materials employed, is slightly elastic and incombustible, it has likewise moisture-repelling qualities.

The English are beginning to send coal to Vienna. They have a depot at Dresden, from whence they are sent to Prague, and are there cheaper than Austrian coal.

A specimen of the bread made from bread fruit, has been exhibited in the Boston Exchange. It is a thin, semi-transparent sheet, of a bright brown color, and in no respect resembles any preparation of bread among us.