

SCIENTIFIC MUSEUM.

Guano as a Manure.

We learn by that excellent monthly periodical, "The American Farmer," (Baltimore), that guano is doing wonders for some poor lands. One case is related of the Hon. James Pearce, who first applied guano in 1845, at the rate of 550 lbs. to the acre of very poor land. It was applied as a top dressing mixed with plaster, for a crop of wheat; the wheat was doubled in quantity, and fine clover succeeded it, and the effects were apparent in two other crops afterwards. There are many different opinions among our farmers respecting the value of guano as a manure. Some assert, that it does not produce results of a satisfactory character, according to its price, and that "it is all worn out in the first crop." Guano, like all other manures of an animal character, should be plowed into the soil, or laid in the hills or rows of crops that are planted and not sown. It is perhaps the best general manure in the world, and there are good and bad kinds of it, and farmers should know this. Johnston states, that of two kinds examined by him, taken from one box, one contained eight per cent. of sand, and the other only two per cent. Some kinds of guano only contain seven per cent. of ammonia, while other parcels contain 25 per cent. Dr. Ure gives the following as the average result of his analyses of genuine guano. Organic matter capable of affording eight to seventeen per cent. of ammonia in the soil, fifty per cent.; water eleven; phosphate of lime, twenty-five; phosphate of magnesia, thirteen; sandy matter, one per cent.—making the one hundred parts. But very little guano is as rich as this in organic matter containing nitrogen. In the production of turnips, it has been found that land, top-dressed with guano, at the rate of 3 cwt. per acre, produced 23 tons 8 cwt. of Swedish turnips (*ruta бага*), while 20 tons of farm-yard manure, to the acre, only produced 18 tons 11 cwt. of turnips. An acre of land for potatoes was dressed with 3 cwt. of guano, and it yielded 18 tons 9 cwt. of potatoes; this was near Paisley, Scotland. An acre of wheat dressed with one cwt. of guano, yielded 48 bushels; and 3 cwt. of guano to the acre produced 64 bushels of barley. This is related on the authority of Prof. Johnston. There can be no doubt of the good qualities of guano as a manure, and on poor soil, or soil worn out by successive crops without manuring, some powerful fertilizer must be employed to redeem the soil from barrenness to fertility; guano appears to be the manure best adapted for this, but, at the same time it is best for farmers in the interior of our country, to conduct their system on the principle of making their own fertilizers, and obtaining them at as low a cost as possible. The nitrate of soda or nitrate of potash (saltpetre), ground along with charcoal, makes a most excellent compound, to be applied for top dressing, along with an equal quantity of ground plaster; this can be obtained in many places of our country where guano cannot.

Influence of Poisons upon Animal Heat as a Cause of Death.

Dr. Sequard, of Paris, has published some peculiar views respecting his experiments with poisons, reducing animal heat. He says he has seen death take place in a rabbit after a diminution of its heat of only 22° of Fah., and he never observed any animal live after he had diminished its temperature more than 44° Fah. Accordingly as the heat is rapidly diminished, so is death produced in less time. When by a wound or poison the temperature of a man is reduced many degrees, his life is in danger from that very cause. It is thus in cholera, palsy, &c.

In cases of poisoning it has been found that the temperature of the person always decreased, and Chossut, who injected opium into the veins of a dog, found the temperature diminish from 105° to 62° Fah. M. Sequard believes that many poisons may kill simply by their action in reducing animal heat. He has found that some poisons which will kill animals when there is no obstacle to prevent the diminution of the body's temperature, will not destroy life when the temperature is sustained by artificial means to its normal degree.—Equal doses of poisons were given to two ani-

mals as much like one another as possible. One was left in a room at a temperature of 46° Fah., the other was kept in a place where the temperature was 75° Fah. The first was dead after a certain number of hours, the other that was kept warm was generally cured very soon. In cases of poisoning by opium, belladonna, tobacco, camphor, alcoholic, acetic, oxalic acid, and many other poisons, physicians should labor to prevent a diminution of heat by keeping the patient as near as possible, by artificial means up to the standard of 100° Fah.

Snuff and its Manufacture.

FIG. 1.

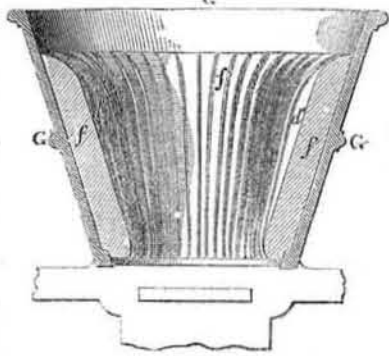

Although snuffing is not a national custom in America, the quantity of snuff made and used every year, is far greater than the majority of our people have any knowledge of, or than we could have believed, until we made some enquiries, and gathered up some information on the subject. But first let us explain its manufacture.

The leaves of tobacco intended for snuff are sorted and prepared with a sauce, which is different in some countries and manufactories. It is composed of sugar, some saltpetre and salammonia, and partially fermented, and the leaves are then tied up in bunches, in which state they are most portable and better for preservation. In England nothing but common salt is allowed to be added to snuff, and this is the custom here. In France, the tobacco used for snuff is generally of a superior character. It is first cut up with a revolving set of knives, fixed on a wheel, after which it is heaped in great masses in wooden bins

FIG. 2.

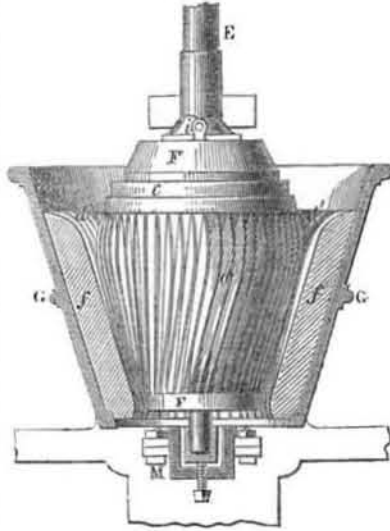

in a large chamber for fermentation. A pipe is introduced into the mass and the thermometer placed in it to regulate the heat. This process generally lasts for a number of months. When the temperature rises to 176°, acid, carbonate of ammonia and nicotine are given off. The air is excluded as much as possible, otherwise acetic acid by fermentation would take place. The mass must be carefully watched that it be not converted into humus. The whole is then ground in mills represented in the annexed figures, which are sections of the mill used in the French government manufactory.

Figure 1 shows the exterior cast metal casing, G, with its lining of thin iron blades, d, which are kept in their position by wedges of wood, f, f. In figure 2 F is the revolving grinder, it is made of cast-iron with projecting segments held tight by an iron collar, c, M is the shaft box, and E is the shaft, to which motion is communicated, causing the grinder to revolve, and thus reduce the tobacco to snuff in the mill, a kind of bark mill. The whole apparatus may be of cast iron, and the

to'acco ground quite damp, when going through the mill.

In England there are pestle mills; these which have pestles receive a motion by machinery and grind up the tobacco (which is quite dry for this operation) into fine snuff, like grinding any substance with a pestle in a mortar. The pestle is iron, and the mortar wood, but this snuff is first ground coarse under horizontal millstones; it is much prized for its particular grain by some connoisseur snuff-takers. Snuff can be colored with logwood and scented with various kinds of oils. There are particular mixtures for different snuffers; some like one kind and some another. The famous Lundy-foot Irish snuff was made out of dried tobacco which was supposed to be over-dried—too much roasted. It was the means, however, of making the fortune of its Dublin manufacturer. No less than 37,422 lbs. of snuff were exported from the United States last year; but the home consumption is far greater than this; more is manufactured, we believe, by a single firm in this city, that of Lorillard, the oldest snuff-making house in the United States, it having manufactured snuff before the revolution.

There are few Americans, as we said before, who take snuff, but many Germans and Frenchmen in the United States use it. There are different kinds manufactured, such as Macaboy, Rappee, Lundy-foot, and Scotch snuff. More of the latter is used than any other, not for snuffing, but for other purposes. In some of our Southern States the females use the Scotch snuff to clean their teeth, and excise their gums after meals by using the snuff along with a tooth stick. Tons of snuff are shipped from New York for North Carolina and Georgia to be used for this purpose. This snuff is also extensively employed for destroying vermin on vines, plants, &c. It is very dry and fine, but how it came to get its name is a query. Perhaps it was the kind manufactured by Gilbert Stuart's father, the first snuff machine mechanic who erected snuff mills in the colonies, and who was engaged in Scotland to come here for that purpose. It is the general custom in Scotland to grind their snuff very dry, and the attendants on the mills have a most disagreeable and unhealthy avocation. At one time the Scotch Highlanders were represented to be great snuffers, and it may be that some of the old settlers in Tennessee, who made their own snuff in their own natural mills, by drying the tobacco leaves, and then rubbing them to powder between the hands—real Lundy-foot—gave it the name which it now retains, but which is unknown as a snuff-taken snuff in Scotland at the present day, where there are ten smokers for one snuffer.

There are large snuff manufactories in Philadelphia, Baltimore, and some other places, as well as New York, but we have not been able to obtain a correct account of the amount manufactured yearly. We have received such information, however, as makes us distrust all published statistics, they come far short of the mark in giving the quantities. Any mill capable of grinding up tobacco leaves into powder is capable of making snuff. The color to any degree of darkness after the tobacco is ground is given by moistening it with a weak solution of the sulphate of iron, and then stirring it up well and adding logwood liquor until it is of the desired shade. Tonca beans and odiferous oils are employed to scent some snuffs, but such oils are not safe to use, they affect the brain and often produce vertigo. Lundy-foot is the safest snuff to use, because almost, it not all the nicotine is expelled by the partial roasting of the leaves. Snuffing, however, is a queer custom when a person reflects upon it, but not more so than smoking.

Salve for Burns.

Please publish the following valuable recipe for scalds and burns, having used it myself and seen its effects on others, I recommend it as having no equal, particularly in cases of scalding by steam from boiler explosions, &c.:—Take any quantity of unslacked lime, put water enough on it to cover the lime; let it stand an hour or more; take off the clear lime water, and to every pint of lime water add one pint of oil (olive or lard oil is preferable, but any kind of lamp oil will answer), put them in a bottle and shake well, and in a few mi-

nutes it will be fit for use. Bathe the part scalded as often as the nature of the case requires; if the skin be badly broken, lay over the wound a very thin piece of cambric muslin; this liniment will keep for years if corked tight in a bottle. Every family should keep it on hand as it costs but little. H. G. G.

LITERARY NOTICES.

THE DAUGHTERS OF ZION—By Rev. S. D. Burghard, D. D.; published by John S. Taylor, 143 Nassau street, N. Y. The above is the title of a new religious work devoted to an account of the most illustrious females of Israel, beginning with Sarah, the wife of the Patriarch Abraham, and concluding with the lives of those distinguished in the New Testament. As an addition to sacred literature, this little book will be interesting to a large class of readers, who are thus enabled to study with greater facility, the striking characteristics of the Jewish heroines of the Bible. It is written in an easy popular style, sufficiently intelligible for every capacity, and yet with proper respect for the dignity of Holy Writ. It can, therefore, be safely recommended as a useful work for perusal, which will aid in extending a more intimate acquaintance with many of those heroic daughters of Zion who acted so distinguished a part in the chronicles of Jewish History. We like to have forgotten to mention that the book is illustrated with several mezzotint engravings.

MINIE'S MECHANICAL DRAWING BOOK—Mr. Minie, of Baltimore, has commenced publishing his excellent text book on Mechanical Drawing for self-instruction, in parts of 25 cents each. This will enable many to take it who would otherwise not do so by paying the whole at once. It is the best work of the kind ever published in our country. For sale by Dewitt & Davenport, 156 Nassau street, this city.

"DELLA'S DOCTORS—Or, A Glance Behind the Scenes," by Hannah Gardner Creamer.—This is the title of an interesting work just published by Messrs. Fowler & Wells (12mo., 362 pages). In this work many wholesome ideas are conveyed under the form of a satirical comment on prevailing social customs and institutions, not even sparing the time-hallowed professions of Medicine and Divinity. The work contains, also, several lively sketches of rural life in New England, evidently drawn from nature, which show a capacity in the writer promising for the future.

THE TEMPERANCE REFORMATION.—Fowler & Wells, New York. The author of the above named work (Rev. L. Armstrong) pleads very enthusiastically in favor of the introduction of the Maine Liquor Law into the State of New York. In the third, fourth, and following chapters he analyzes the reasons set forth by the remonstrants against the introduction of the law, which he irrefragably demolishes to his own satisfaction. In the prospective effects of the Maine Law, if obtained as a Statute of New York State, we are enlightened as to what will be the future condition of our population. In addition to other information, such as a history of the Temperance Cause and its progress, there are several spirited tales and anecdotes, with a reprint of the Maine Liquor Law, and six reasons for its adoption by the people of New York.

THE PRINCIPLES OF HYDROPATHY—Fowler & Wells, New York. This is a cheap little book, the price being only 12-1-2 cents, explaining the principles of the Water Cure System. The author states that he was cured from the verge of the grave by its treatment. *Credat Judæus!*

OLIVE BRANCH—Boston, Mass.; published every week, at \$2 per annum, by Thos. F. Norris. A new volume of this sterling family paper, commences its eighteenth year in a few weeks.

MECHANICS

Manufacturers and Inventors.

A new Volume of the SCIENTIFIC AMERICAN commences about the middle of September in each year. It is a journal of Scientific, Mechanical, and other improvements; the advocate of industry in all its various branches. It is published weekly in a form suitable for binding, and constitutes, at the end of each year, a splendid volume of over 400 pages, with a copious index, and from five to six hundred original engravings, together with a great amount of practical information concerning the progress of invention and discovery throughout the world.

The Scientific American is the most widely circulated and popular journal of the kind now published. Its Editors, Contributors, and Correspondents are among the ablest practical scientific men in the world.

The Patent Claims are published weekly and are invaluable to Inventors and Patentees.

PRIZES—We solicit attention to the splendid Prizes offered for the largest number of subscribers, consisting of a SILVER PITCHER worth \$60; a set of the ICONOGRAPHIC ENCYCLOPEDIA worth \$35; DEMPSEY'S MACHINERY OF THE NINETEENTH CENTURY, and C. B. Stuart's great work upon the NAVAL DRY DOCKS OF THE UNITED STATES.

Letters should be directed (post-paid) to

MUNN & CO.,

128 Fulton street, New York.

Terms! Terms! Terms!

One copy, for One Year	\$2
" " Six Months	\$1
Five copies, for Six Months	\$4
Ten Copies for Six Months for	\$8
Ten Copies for Twelve Months,	\$15
Fifteen Copies for Twelve Months,	\$22
Twenty Copies for Twelve Months,	\$28

Southern and Western Money taken at par for subscriptions, or Post Office Stamps taken at their full value.