

AN EFFICIENT WOOL-DRIER.

The wool-drier which we illustrate is, in general, characterized by a casing in which a series of endless carriers or aprons are arranged mounted on rollers, the casing being heated by steam pipes, so that the wool, in circulating, is dried by the action of the radiating heat. The apparatus is the invention of James W. Spencer, of Olneyville, R. I.

The casing of the apparatus has a projecting lower portion provided with a feed orifice, which may be closed by a hinged cover. An endless apron, with two horizontal runs, is mounted in the lower portion of the casing and extends beneath the feed orifice. A second endless apron is mounted in the casing above the first apron, and has three runs, one extending upwardly from the first apron, another extending horizontally, and a third extending diagonally between the first and

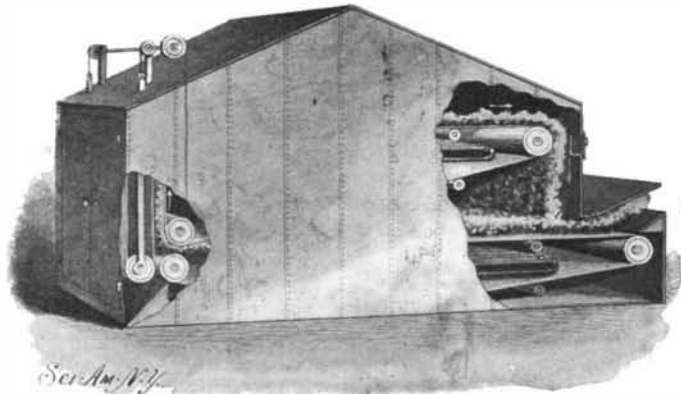

SPENCER'S WOOL-DRIER.

second runs. At the rear of the casing a third endless apron is vertically mounted and passes in close proximity to the vertical run of the second apron. This third apron is so mounted that it may be raised or swung aside to permit the discharge of the wool through a door in the casing. Steam-heating pipes are horizontally placed between the runs of the first and second aprons. An observation opening is cut in the casing above the forwardly projecting portion.

In operation, the wool is fed through the proper orifice, until the machine is sufficiently charged. The cover is then closed. The wool passes along the top run of the lower apron, up between the vertical run of the second apron and the front run of the third apron, then forward on the horizontal run of the second apron, to fall back upon the lower apron, whence it is carried rearward again. The operation is repeated until the wool has been sufficiently dried. The wool is then discharged by opening the door in the rear and swinging the apron aside.

A NOVEL VALVE FOR PNEUMATIC TIRES.

A valve for pneumatic tires has recently been patented by William G. Urmson, of New Brunswick, N. J., which is so constructed that all the parts may be readily replaced when necessary. The valve casing is designed to be inserted through the rubber nipple extending from the tire, and is provided with exterior ribs to retain it in place. An outwardly extending flange on the upper portion of the casing obviates the danger of forcing the casing too far into the nipple. On the outside of the nipple a supporting and strengthening thimble is fitted. The casing is interiorly threaded, and at the base of the threaded interior a

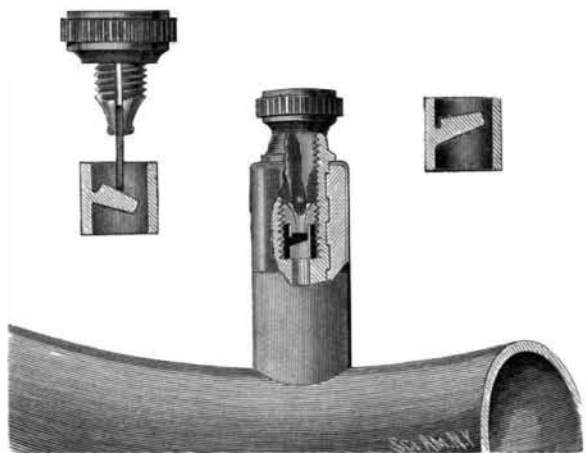

URMSON'S VALVE FOR PNEUMATIC TIRES.

valve seat is formed. A valve carrier having an exterior screw thread is received within the casing and carries an inner flexible tube having an integral flap valve which, normally inclined, takes a firm seat against the valve carrier. The plug or cap for closing the valve casing is threaded and longitudinally slotted. Pivoted near its end in the slot is a tongue which may be caused to open the valve for deflating the tires. When it is desired to permit the air to escape, the tongue is allowed to fall from its normal position, so that the smaller end of the tongue will pass through the valve carrier by screwing the plug or cap inward to unseat the valve. The essential features of the in-

vention are the improved flap valve, the upper flange on the casing, which prevents the inner end of the casing from coming into contact with the opposite side of the tire, and the novel deflating devices.

Test of Antiseptic Substances.

In the Zeitschrift für Angewandte Chemie, Th. Bokorny, says Science, gives the results of a study of the antiseptic action of various substances. A culture medium of half per cent egg albumen or peptone, with one-tenth per cent potassium phosphate, two-tenths per cent magnesium sulphate and a trace of calcium chloride was infected with the bacteria of decay, and after addition of the substance to be tested placed for several days in an incubator. Among inorganic compounds, silver nitrate and mercuric chloride have about the same value, 0.002 per cent killing all organisms in two days. The antiseptic limit with silver nitrate is 0.0002 per cent; with mercuric chloride, 0.001 to 0.0002 per cent. Copper sulphate is nearly as active, 0.005 per cent killing all organisms in twenty-four hours and 0.001 per cent preventing decomposition. Zinc sulphate 0.01 per cent kills infusoria in eighteen hours, but 0.1 per cent is not completely antiseptic, while cadmium sulphate toward algæ and infusoria is weaker than the zinc salt, but toward bacteria stronger, 0.02 per cent being antiseptic. Lead acetate and nitrate in 0.1 per cent solution only delay decay, while it is prevented by the same strength of iron sulphate solution. The fluorides are not strong antiseptics, the limits being for hydrofluoric acid 0.02 per cent, barium fluoride 0.3 per cent, aluminum fluoride 0.1 per cent, calcium fluoride 0.03 per cent, ferric fluoride 0.06 per cent, magnesium fluoride 0.05 per cent. Ammonium fluoride 0.1 per cent is without action, but sodium fluoride 0.1 per cent is antiseptic; potassium fluoride is rather more active.

AN IMPROVED FLOORING.

The engraving which we present herewith illustrates a flooring which can be readily secured in place and which will not warp. The flooring in general consists of boards provided on their sides with rabbets for forming bottom flanges which are transversely slotted. Clamping irons are made to pass partially into the slots and are provided with arms adapted to be bent down over the board flanges. Of our illustrations, Fig. 1 is a perspective of the flooring with a portion broken away to show the clamping iron bent in position, and Fig. 2 represents details of construction.

The flooring comprises a series of rails formed at their lower ends with flanges located alternately on opposite sides of each rail. The rails are embedded in a layer of cement and firmly on the alternate flanges. On the upper end of each rail extends a continuous horizontal flange. Over the hardened cement a thin coating of tar is poured and on this coating boards are placed, which at adjacent sides are formed with rabbets to produce bottom flanges, transversely slotted in a line with the upper continuous flange of the rails. These board slots receive the bodies of the clamping irons. The lower bent ends of the irons pass under the upper continuous rail flanges, a suitable opening having been made for that purpose in the hardened cement. The upper end of each clamping iron is formed with two arms, which are bent in opposite directions over the adjacent board flanges. A covering strip cut out at its under side may be made to receive the arms of the clamping irons bent down upon the flanges. The top of the strip is flush with the boards and can be nailed in position. By the arrangement described, the boards are securely fastened in place, so that they are prevented from warping. Longitudinal shifting is prevented by the transverse clamping irons extending into the adjacent side flanges of the adjoining boards. The flooring has been patented by Thomas Cantwell, No. 1809 Amsterdam Avenue, New York city.

A Friendly Criticism.

The following amusing but brief review of the NAVAL SUPPLEMENT recently appeared in The Electrical Engineer, of London:

We have received the SCIENTIFIC AMERICAN NAVAL SUPPLEMENT and find in it most interesting and fully illustrated descriptions of the different types of vessels in the United States navy. The only fault we find with the paper is a note to the effect that it was entered as second-class matter at the New York post office. It is a first-rate issue in spite of the above.

A NEW VEHICLE WHEEL.

The subject of the accompanying engraving is a vehicle wheel characterized chiefly by the novel form of the hub and felly expanding devices, and patented by Robert G. McDowell, of Anaconda, Mont.

The hub of the wheel is provided with a front ring having wedge-shaped inward projections which receive between them the tenons of the spokes. Another ring has forward projections which extend between the spokes outside of the first named projections, as seen in

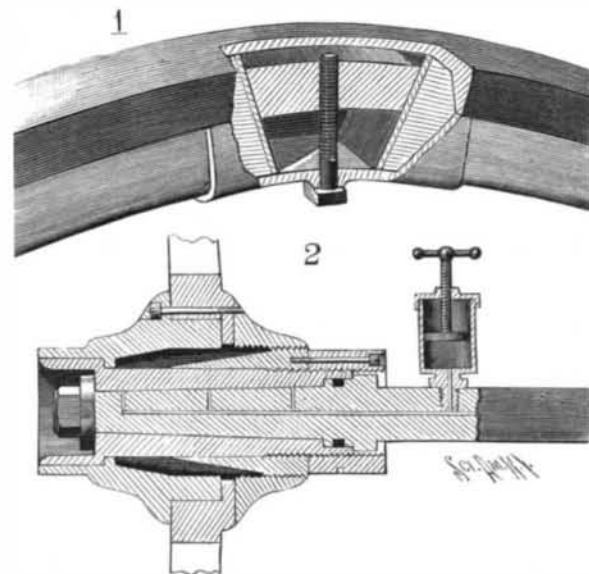

MCDOWELL'S VEHICLE WHEEL.

both our illustrations. The rear portion of the hub is formed by a ring having a threaded interior screwing upon a threaded tapering sleeve movable on the hub-box. This tapered sleeve fits beneath and wedges against the spoke tenons, and by its means the spokes may be forced outwardly or may be allowed to fall inwardly. The sleeve is held in place by a ring screwing upon the hub-box and acting after the manner of a jam-nut. Bolts may be employed to hold the various parts together. A lubricator is provided consisting of a piston with a screw-rod which forces oil from the cup into proper channels in the hub-box. In a hub of this construction the spokes and other parts may be readily adjusted when shrinkage has loosened them.

A device whereby the felly may be tightened upon the tire is also provided. The device consists of a wedge-shaped block whose inclined sides coact with the similarly beveled ends of the felly. From the block through a plate on the interior circumference of the felly a screw passes which enables the block to be drawn toward the hub so as to expand the felly.

Dangerous Odors.

The Boston Transcript tells its readers what smells are dangerous. A single sniff of highly concentrated prussic acid will kill a man as quickly as a shot through the heart. The odor of a bad egg is due to the presence of sulphureted hydrogen, and the objectionable

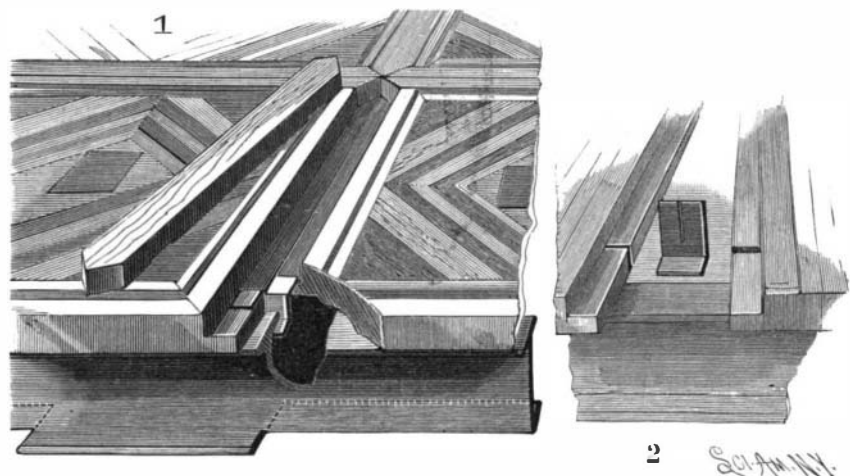

CANTWELL'S FLOORING.

perfumes of sewers and bone factories are attributable chiefly to the same gas. Chemical laboratories are famous for bad smells. Berzelius, who discovered the element called "selenium," once tried the experiment of permitting a bubble of pure hydrogen selenide gas to enter his nostrils. For days afterward he was not able to smell strong ammonia, the olfactory nerves being temporarily paralyzed. Selenium gas has the odor of putrid horseradish. Tellurium is even worse. There is a story of a physician whose patient, a lady, refused to take an absolutely necessary rest because she was so fond of being always on the go in society. He gave her a pill containing a small quantity of tellurium, and her breath was affected by it to such an extent that she was not able to appear in public for a month. She never guessed what the trouble was. The volatilized essential oil of roses is supposed to cause "rose cold." This peculiar complaint is so far nervous in its character that paper roses sometimes excite it.