

Scientific American.

THE ADVOCATE OF INDUSTRY, AND JOURNAL OF SCIENTIFIC, MECHANICAL AND OTHER IMPROVEMENTS.

VOLUME VII.]

NEW-YORK, MAY 29, 1852.

[NUMBER 37.]

THE
Scientific American,
CIRCULATION 16,000.

PUBLISHED WEEKLY
At 128 Fulton street, N. Y., (Sun Buildings),
BY MUNN & COMPANY.

Hotchkiss & Co., Boston.
Dexter & Bro., New York City.
Stokes & Bro., Philadelphia.
Jno. Thomson, Cincinnati, O.
Cooke & LeCount, San Francisco, Cal.
Courtenay & Wienges, Charleston, S. C.
John Carruthers, Savannah, Ga.
M. Boullemet, Mobile, Ala.
Sidney Smith, St. Louis, Mo.
Barlow & Co., London.
M. M. Gardissal & Co., Paris.

Responsible Agents may also be found in all the principal cities and towns in the United States.
Terms—\$2 a-year—\$1 in advance and the remainder in 6 months.

RAIL-ROAD NEWS.

Railway Curves, Axles, &c.

A correspondent of the Journal of Commerce has been discussing the question of railway accidents and their remedies. He has given to the world some excellent and judicious remarks on the subject. He points out the following evils of our railway system:—

First. Elevating the outer rail instead of the inner one, upon the curved portions of the railways.

Second. Large driving wheels, which require much coning, to go round the curves, and therefore exert an injurious lateral pressure upon the rails.

Third. Coupling the wheels, whereby the flanges are liable to abrade the rails, as each axle is prevented from assuming its natural position of normal to the curve.

Fourth. Two engines, tugging first on one side and then on the other, like a man sculling instead of rowing in a boat, whereby the rocking motion is greatly increased; and if it operates simultaneously with that produced by the cross winding of the axles, is almost certain at least to throw the locomotive off the rails.

All these causes tend materially to produce those accidents which usually take place upon the curves; but the greatest evil is the want of proper attention to the maintenance of the permanent way, more particularly upon the curves, and were these properly attended to, comparatively few accidents would happen upon them, more than on the straight parts of the line; but that affords no just reason for neglecting the other evils complained of. But still, the great desideratum is the perfection of the permanent way.

Talk of a director walking over a railway to examine it! why, he may as well send a carrier pigeon over it. Take a level, Mr. Director, and try round the curves, and examine the charts and then "mend your ways," "mend your ways," for they are sure to require it; it is a simple mathematical proposition, but worked out with a pickaxe, in the open air, away from the quiet, snug and comfortable office of the directory, and the engineer. The word of an ignoramus is generally taken that it's "all right," but let any man who has any common sense take a level, and put it across the rails, and he will no longer be in doubt as to the cause of many of the accidents which occur.

Unparalleled Speed.

They are making time on the Hudson River Railroad now, that beats the speed on any of the English railways. The 6 o'clock train out of New York, Saturday morning, the 15th inst., made the distance in three hours and one minute. The following is the running time;—From 31st street, New York, to Peekskill, 50 minutes; to Fishkill 23 minutes; to Poughkeepsie, 20 minutes; to Rhinebeck, 20 minutes; to Hudson, 32 minutes; to Albany, 36 minutes; total 181 minutes. This is equal to about 50 miles an hour.

WOODWORTH'S SEED PLANTER.—Fig. 1.

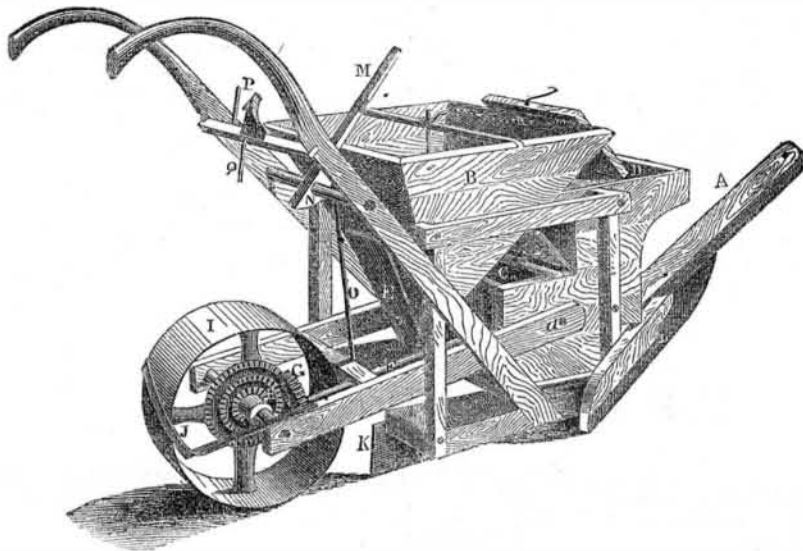
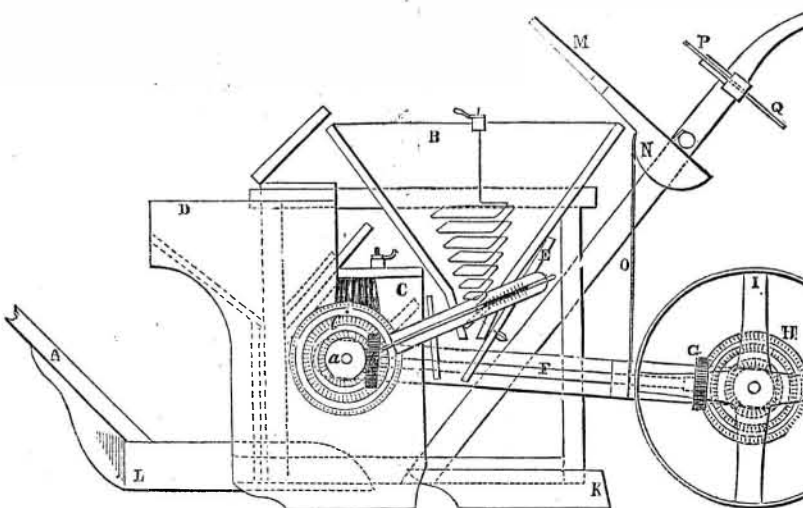

Figure 1 is a perspective view, and figure 2 is a vertical section of the Patent Seed Planter of Joshua Woodworth, of Mittineague, West Springfield, Mass. The foundation is a smoothing or surface board, with a plow or channeller, L, for opening the ground for the reception of seed; the coverer, K, is attached to the under side behind. A is the pole for drawing the planter; B is a hopper to contain ashes, plaster, lime, or poudrette, for the kind of seed which may be planting; D is a box for containing the seed; at the back end of this box there is a broad roller (c fig. 2) which revolves tight with its face passing through the back end of said box. No seed can pass out of this box, unless the roller takes it up. For this purpose, one or more recesses are made in the face of the roller, the seed passes into these as the roller revolves, and is carried over under a brush in the chamber, C, and then the seed drops out when the recess of the roller gets to the under side. This seed roller receives motion by a train of gear from behind; I is a broad-faced wheel, which has bevel cogs on its hub, H; J is a scraper to clean the wheel; G is a pinion on a shaft, F; this shaft has a pinion (b, fig. 2) on its forward end, which gears into cog gearing on the shaft, a, which is the shaft of the seed roller. When the wheel, I, revolves, it gives motion to the seed roller. This wheel, I, is made to be raised up at pleasure, so as to stop planting at any moment deemed necessary, while the apparatus is being drawn. The said wheel, with the shaft, F, and its gearing, are secured in a swinging frame of which, a, is the axis. To a brace of this frame is secured a strap or cord, O, which passes over a cam, N, and is secured on the lower end of lever M, which works on an axial shaft secured between the two stilt-arms of the planter. By taking hold of the lever, M, and bringing it downwards towards the back end of the planter, the wheel, I, is raised from the ground, and the seed planting operation is stopped. The lever, M, is retained in its place, suspending the wheel frame by a spring catch, P, which acts as jaws to embrace the lever. The arm,

Figure 2.



Q, is for the purpose of relieving the lever, M, from the spring catch, when the wheel, I, is to be lowered. The raising and lowering of the wheel frame, to suspend or put in operation the planting devices, can be done in a single moment. The opening or openings made in the seed roller, for the reception of seed, are such as to deposit the seeds at any required distance apart. The hopper, B, for the fertilizing material, which is placed behind the seed box, has a wire basket in it, which acts as a spring and regulator to govern the supply of fertilizing compound to the seed. The bottom of this hopper has a valve on the mouth of the chute, E, and it is secured to the lower end of the wire forming the basket; the upper

end of this wire has a thread turned on it, and it passes through a cross bar over the mouth of the hopper; a nut works on the thread of the wire, therefore the basket can be raised or lowered by turning the said nut, and the valve on the exit end of the hopper can thus be opened to any extent desired, or it can as easily be entirely closed. The governing of the actions of the seed planting and fertilizing devices, are thus very easily accomplished. The valve for the poudrette hopper is also actuated by pins placed in the end of the seed roller, so as to operate a lever and make the valve open to drop the fertilizing material upon the seed, at such times and distances as the seeds are deposited in the

furrows. The ground undergoes four processes of pulverization in the operation of planting: first, there is a smoothing board in the front end of the planter; second, the action of the plow; third, the covering operation, and then, after this, the broad-faced wheel, I, crushes all the clods, and packs the seeds with just that amount of pressure required. This apparatus can plant eight acres per day, in the most perfect manner, with the ordinary labor of one man and a horse. Two planters can be fixed so as to be drawn by one horse, for the apparatus is quite light. It can do the work better than planting with the hoe, and two horses with four planters attached together—which might be done when the weather demanded prompt action—will plant thirty-two acres in one day.

Mr. Woodward has made application for a patent for his improvements, and he warrants his machine to work to the satisfaction of any reasonable man. More information may be obtained by letter addressed to him at his place of residence.

The Art of Growing Trees from Cuttings.

Professor Delacroix, of Besancon, in France, has discovered a mode of propagating from cuttings, which is not only successful in case of roses and other plants easy to live, but apples, pears, plums, apricots, &c. Out of an hundred cuttings put out in June, not one but was thriving in August in the open air, without shade or extra care, except watering a few times soon after they were planted. His method is to put the whole cutting in the ground, bent in the form of a bow, with the centre part up, and just on a level with the surface, at which point there must be a good bud or shoot, which is the only part exposed to the air; the other being protected by the earth from drying up supports and gives vigor to the bud, which starts directly into leaf, and in its turn helps the cutting to form roots and the whole even forms a thriving tree. The method of setting them is to form two drills about three inches apart, with a sharp ridge between, over which bend the cutting, and stick an end in each drill, and cover up and press the earth firmly, and water freely. Cuttings should be of the last years growth fresh and vigorous.

Buffalo and Lockport Railroad.

The Lockport Courier states that the Buffalo and Lockport Railroad Company has been organized, and that it has been resolved to build an independent line of railroad from Lockport to Buffalo, connecting at Lockport with the Rochester, Lockport, and Niagara Falls Railroad. It is contemplated to construct that part of line between Lockport and Tonawanda this summer, so that in connection with the Buffalo and Niagara Falls Railroad, a railway communication will be opened during the fall and winter between Buffalo and Lockport, having the residue of the line completed by the spring of 1853.

Commercial Navy of Great Britain.

The commercial steam-navy of Great Britain, available for the national defence in the time of need, amounted, on the first of January last, to twelve hundred and eighteen vessels; and it is stated upon authentic information, that there were at least one hundred steamers in advanced states of construction, or completed since the beginning of the year, and not included in the official return. The vessels constituting this great steam-navy vary in size from two hundred tons burthen to three thousand. The steamers of four companies now employed in the ocean mail contract service, and warlike operations, comprised seventy vessels, amounting in the aggregate of tonnage to 93,431 tons, with 32,500 engines horse-power.