

NEW INVENTIONS.

Lamp Oil Can for Machinery.

John Williams, of Brooklyn, N. Y., has taken measures to secure a patent for an improved oil can. The can is made, so as to contain a lamp united to the can in front of the spout. While filling the can with oil, there is an aperture through which the oil also passes into the lamp to fill it. There is a valve in the oil can, at the bottom of the tube; this valve has a spring on it, and a button; by pressing the finger on the button, while holding the can by the handle, the valve is operated and the oil allowed to pass into a tube and out of the spout on to that part of the machinery which is to be lubricated. The valve is self-closing, and prevents the escape of any oil except when operated by the finger. The lamp throws its beams upon the machinery, and affords a most excellent light, so as to enable the engineer to lubricate the joint requiring the oil. At night this improvement is of great advantage, it is also a good one for many dark places, where much machinery, of a necessity, is located. It will prevent, as often happens, the engineer from missing the place to be oiled.

New Tally-Board.

Francis N. Clark, of Chicago, Ill., has taken measures to secure a patent for a Tally-Board for keeping a correct account of a cargo of lumber, or any other commodity, as it is being discharged. There are a series of screw rods properly secured over a board, these rods being fixed so as to be moved either to the right or left, according as they are turned upon the board. Underneath each nut of a screw rod, there is a space which is graduated in any proper manner by turning either screw rod. The graduated space shows how far a nut has been moved on the rod. According as the nuts and rods are turned on the graduated spaces, so are the tons or half tons of the delivered cargo registered on the board.

This is a great improvement on five chalk lines and a cross—the common mode of tallying now practiced.

To Prevent Chimneys from Smoking.

Eliphalet Nye, of Nashua, N. H., has taken measures to secure a patent for an improvement in chimneys to prevent them from smoking. The nature of the invention consists in applying a portion of a syphon to the upper part of a chimney, so that when it is attached, a perfect syphon is formed, the upper part of the chimney, being the long leg, and the portion which is attached, the short leg. By this arrangement, a current of air is produced in the upper part of the chimney, and the smoke, as a natural consequence, is always carried out of the chimney.

Improvement in Steam Boilers.

R. S. Rettinger, of Louisville, Ky., has taken measures to secure a patent for an improvement in steam boilers; the boiler is constructed with an inside shell, having small flues attached, said shell and flues being within the boiler, and so arranged that the inside shell and the small flues may be detached from the boiler and lowered into a pit to be cleansed.

Improved Railroad Car Truck.

W. D. Arnett, of Fairfield, Jefferson Co., Iowa, has taken measures to secure a patent for an improvement in Railroad Trucks, the nature of which consists in the employment of friction wheels applied in a peculiar manner to the axis of the truck wheels, for the purpose of diminishing friction.

New Machine for the Gold Regions.

Within a few days we have seen the model of a machine, named the Plano-Spherical Stamper, Grinder, and Amalgamator, for reducing the gold quartz to powder, and amalgamating the gold at the same time with quicksilver, which is unique for these purposes, and embraces qualities of a totally different and superior character to any other used for the same business. Measures have been taken to secure it by patent, and for effectiveness, simplicity, and durability, it will create no small sensation when brought before the public, which will be done very soon, as a large machine is now being constructed.

Improvement in Wheels.

Messrs. D. H. Dotterer & T. P. Kinsey, of Scranton, Pa., have taken measures to secure a patent for an improvement in cast-iron spoke wheels. The rims and hubs are connected by spokes, which are tangential to the periphery of the hub. The tangential spokes allow the rim of the wheel to contract without splitting, these spokes obviate the necessity of dividing the hub to prevent the splitting by the contraction consequent on the cooling of the metal after being cast

To clean carpets, make up a strong lather of soap, by cutting it into small pieces and dissolving it in boiling water; let it cool, and then pound the carpets well in it, by a pounder, after which the carpets should be pounded five times in clean cold water; they are then to be hung up and dried in the atmosphere.

To preserve out-door wood-work, such as fence, &c., boil together 1 gallon of coal tar, 2½ lbs. of the sulphate of zinc, and lay it on hot with a brush.

PAINE'S PATENT SYSTEM OF VENTILATING RAILROAD CARS.

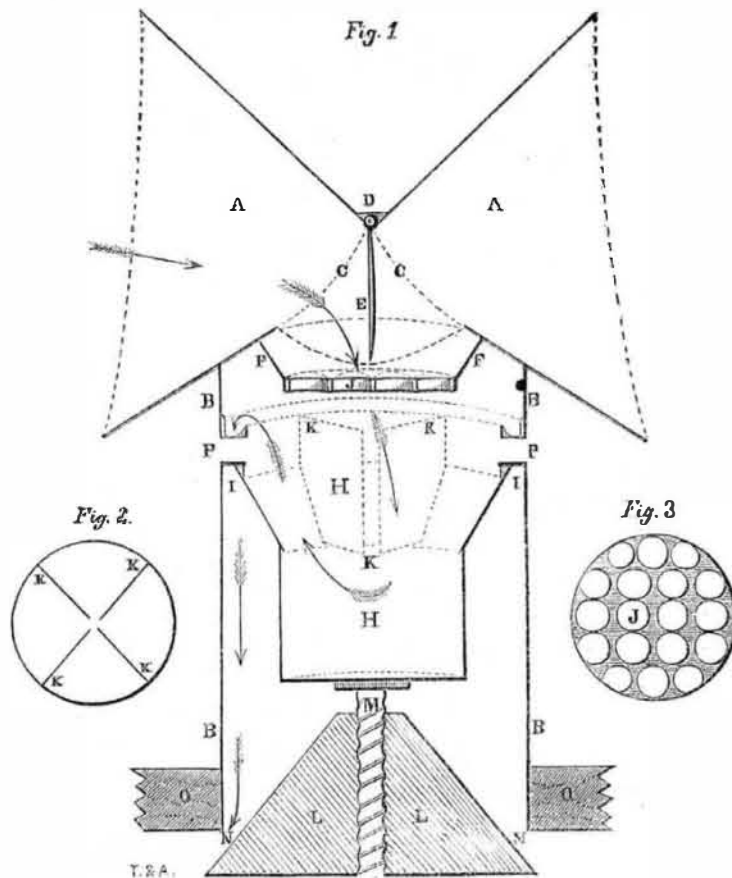

The accompanying engravings represent the improvements made by Henry M. Paine, of Worcester, Mass., which were patented on the 6th of last January, and the claim for which was published and noticed in our regular list of patents for that week. Figure 1 is vertical section of the apparatus for taking in the air, and figs. 2 and 4 are plan views of parts belonging to it. This apparatus is erected on the roof of a railroad car, communicating with the air outside, and letting it into the car. Fig. 4 is a plan view of the windows of a car showing how the ventilation is conducted.

Two cones, A A, with their apex joined, are set upon the top of a vertical cylinder, B B B, in such a manner that their axis will be at right angles with that of the cylinder. At the junction of the cones with the cylinder, an opening, C C, is made through the cones, so as to enable them to communicate with the cylinder. At the intersection, D, of the cones, A A, a flap valve, E, is hung, and is of sufficient area to cover the apertures, C C, in

the cones. The axis of the cones is set on a line with the car's course, and the currents of air entering the mouth of the cone impinge against the flap valve, and cause it to close the aperture of the opposite cone, and deflect the air downwards into the vertical cylinder, and thence into the car.

As the air that is in the immediate vicinity of the train, is more or less charged with dust or cinder, the following arrangement is made to arrest all particles of matter held in suspension by the passing currents, and prevent them entering the cars.

The neck of the cylinder, B B B, near its junction with the cones, A A, is contracted by a conical diaphragm, F F. Under this diaphragm is a tank, H, into which the dust and cinder entering with the air, is precipitated by its superior gravity—the air passing over the top of the tank, H, as indicated by the arrows, and then down the spaces, I I, between the vertical cylinder, B B B, and the outside of the tank, H, into the car.

Experiments have proved that when the

Figure 4.

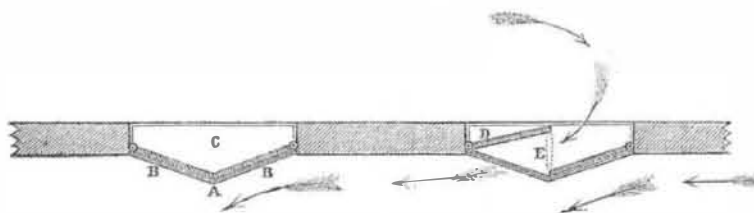

air enters in a large volume through the mouth of the diaphragm, it will bend and carry over in its centre particles of dust and cinder into the car. In order to prevent this result, the neck of the diaphragm is filled with short tubes (J, figs. 1 and 3) which divide the volume of air into a number of jets, and effectually precipitates the dust and cinder held in suspension by the passing air.

When the tank is left with a clear capacity, the cinders that have accumulated in it, are

own into eddies, and carried over into the car, by the first that enter on starting the car. To obviate this difficulty, the tank is divided into compartments (K K K K, figs. 1 and 2.)

The vertical descent of a strong current of air would incommode persons in its immediate vicinity, and to prevent such action, a conical valve, L, is sustained and worked by means of a screw, M, attached to the bottom of the tank, H. The air, in its descent, acting against the sides of the valve, L, is deflected

in radial lines through the car, over the heads of the passengers.

The quantity of air entering the car can be graduated by the working of the screw, M, closing or opening the aperture, N, between the cone valve, L, and roof of the car, O.

As rain and snow will enter the cars with the air, and be deposited in the tank, the supporters (P P) of the tank, H, are made hollow, so as to convey outside of the cylinder, B B B, and on to the roof of the car, any excess of water that may accumulate by the causes mentioned.

The use of the ventilator just described, in winter, entirely removes all annoyances of cold draughts, and maintains an equal temperature throughout the car, and in summer, to a great degree, prevents the entrance of dust or cinder at the windows; but with strong winds against the sides of the train, the quantity of air entering the injectors is not sufficient to counteract the lateral pressure against the open window; therefore a modification of the window itself has been made the subject of successful experiment, and the diagram, fig. 4, is given in explanation of it.

The window is divided into two leaves, which are hinged to either side of the window frame, and when closed form an obtuse angle with the car's side, as seen at A, B B being the sashes. The stools of the windows, C, project from the car's side equal to the distance, and in conformity with the angle formed by the window sash. When the window is to be opened, the rear sash, D, is opened inwards, leaving the front sash closed. The air, impinging against the closed sash, is deflected from the opening made by drawing in the sash, D, as indicated by the arrows, and tends to form a vacuum at the point E, which the air in the cars, rushes in to supply, thus creating a draught out of the open space.

Without enumerating further the merits of this invention, it is offered to the favorable consideration of all who feel interested in accomplishing the end for which it is recommended. There need be little or no additional expense incurred in applying this improvement to new cars, while the attachment upon old cars only involves an expense of about one hundred dollars, and a detention of but a few hours, without mutilation or disfigurement of the carriage. The invention is so simple in its detail, that one skilled in carpenter's work will have no difficulty in applying it. H. J. Hale, 146 Broadway, this city, is the General Agent.

McCormick's Reaper.

It is well known that our patent laws provide for the extension of patents for seven years beyond the first term of fourteen years, if the inventor has not been suitably compensated. The application for the extension is made to the Commissioner of Patents, who has full control of the matter. When, therefore, an application is made to Congress for the extension of a patent, it is presumed to be for a second extension—something not provided for in the Patent Laws. This gave rise to the sentence in reference to the extension of McCormick's patent on page 205, which states, "it [this patent] was extended, we believe, once before." The patent was never extended, as we learn by the Report of Senator Dawson on the subject, which was ordered to be printed on the 30th of last month, and which we have just received. Mr. McCormick has obtained three patents for improvements in Reaping Machines, one in 1834, and two since that time. The first expired in June, 1848, but he made application for its extension in the prescribed way. Edmund Burke, the then Commissioner, did not grant the extension, from the fact that some of the features and claims of Mr. Hussey's patent, dated December, 1833, conflicted with McCormick's, but in evidence submitted, it appeared that Mr. McCormick invented his machine in 1831. The evidence taken was somewhat informal, and this led the Commissioner to refuse the extension. It appears that Mr. McCormick never made a cent on his first patent, and it is for it that he wishes the extension, and which Mr. Burke now states should, in justice, be extended, and this will make the whole term twenty-one years; he recommends the extension of Hussey's also,—this is fair. We make the correction as a matter of honest principle.