

NEW EMERY WHEEL DRESSER.

Any one who has ever had anything to do with emery wheels knows that the efficiency of a wheel depends upon the condition in which it is kept. Good work cannot be done with a wheel covered with ridges or hills and valleys, and, besides this, an untrue wheel is sooner worn out than a true one. For these reasons, to say nothing of the wear and tear of the machine in which the wheels are used, it is essential that every user of an emery wheel should have some efficient means of dressing them, so as to always keep them in working order.

We give an engraving of an emery wheel dresser which has given excellent satisfaction. It consists of a cutter made from the best tool steel carefully hardened, having a cellular structure formed by series of radial conical holes. This roller is journaled in a suitable handle, which is provided with fingers for catching on the rest of the grinding machine. With this construction the roller or cutter may be brought to bear on the periphery of the emery wheel with any desired pressure. The cutter rolling in contact with the wheel soon reduces the surface to the required working condition.

This cutter has the advantage over all others in remaining efficient so long as any of it remains.

This useful tool is made by the Standard Tool Co., of Cleveland, O.

A CAR RECEIVER FOR BILLS OF LADING, ETC.

A device for use on railway cars, providing a convenient receptacle for condition cards, bills of lading, etc., and so constructed that the contents will be kept clean and be readily accessible when required, is shown in the illustration herewith. It forms the subject of a patent issued to Mr. George W. Turner, of South Omaha, Neb. The device is suspended beneath the car, preferably on a pivoted rail having a handle at each end, whereby it may be accessible from either side of the car. A cylindrical shell or jacket has an opening at one side normally closed by a semicircular cover, the shafts forming the pivots for the side ears of the cover being journaled in each head of the shell. On the outer end of each shaft is a hand wheel, and the inner ends of the shafts are attached to a drum adapted to be rotated within the shell by means of the shafts. The drum has longitudinal ribs on its periphery, each having an undercut recess in its side faces constituting slideways. Between one or more of the ribs, as shown in the sectional view, is a chamber covered by a lid fitting in the slideways, the chamber being adapted to receive documents. The surface compartments on the peripheral surface of the drum between the ribs are adapted to receive condition cards of defects or other cards containing usual notices or information, such cards being held in position in their several compartments by having their side edges entered into the slideways. The drum may be revolved by either of the end shafts, to bring the inner end of any desired chamber or compartment into register with a semicircular jacket slot, concealed by the jacket

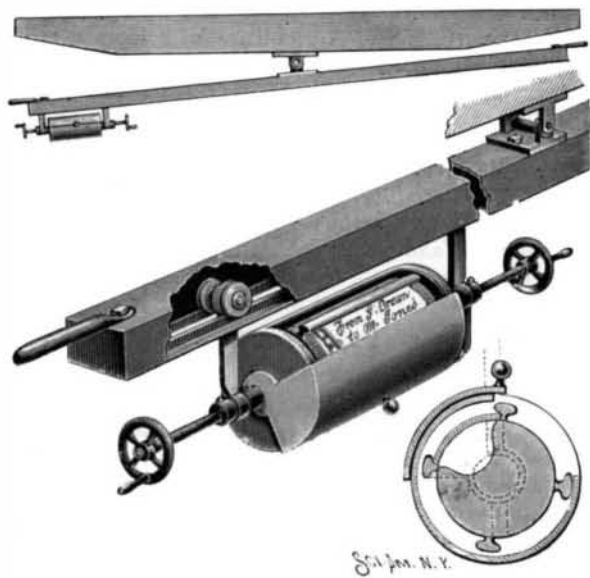

TURNER'S STORAGE RECEPTACLE FOR CARS.

cover when closed. The rail from which the device is suspended is preferably made of a single piece of metal, rolled to form two spaced tracks to accommodate four or more grooved wheels arranged in pairs. The rail is closed at its ends by buffer blocks or their equivalent, and to prevent the shell or jacket from turning, one hanger is provided with an angular foot at its lower end, engaging lugs on one end of the shell.

ACCORDING to Census Bulletin No. 66, the total number of vessels on the great lakes December 31, 1889, was 2,784; the total gross tonnage, 924,472; and the total net tonnage, 780,119. The estimated carrying capacity of these 2,784 vessels was 1,254,271 tons, and the commercial valuation was \$48,809,750.

Internal Strains in Masses of Steel.

Visiting, in 1886, the several works at and near St. Etienne, where the chrome steel projectiles were being produced, their successful manufacture being then of comparatively recent date, I saw, at more than one establishment, a large number of projectiles which had sustained spontaneous fracture. In one store where the finished shot were stacked, after the lapse of the period during which the tendency to the development of cracks or to rupture was stated to diminish gradually, I saw the head of one out of a pile of projectiles which had quite recently been projected to a distance of many feet by the violent spontaneous rupture of the metal. Instances of the development of flaws in these projectiles are now, so far as our experience at Woolwich goes, exceedingly rare, and the remarkable power possessed by these formidable punching tools of pene-



THE STANDARD EMERY WHEEL DRESSER.

trating 8 to 10 inches of armor without even sustaining any important alteration in dimensions is a convincing proof of the uniformity of structure and mechanical stability of the highly dense and tenacious material of which they are composed.

The importance of rest in bringing about a diminution, if not the entire disappearance, of internal strains in masses of metal, is illustrated by the behavior of these chrome steel projectiles, which, at any rate in the earlier days of their manufacture, it was found necessary to store for several months before their transport to a distance could be ventured upon. My report of 1865 on this subject gives illustrations of the recognition, already at that period, of the effect of time in establishing chemical equilibrium in masses of metal. Thus, the United States government had then recently instituted comparative experiments with iron guns newly cast, and with others produced at the same time, but preserved for lengthened periods, which demonstrated the importance of attention to this matter; and the object aimed at and attained by Rodman in his proposal to cast iron guns of large caliber upon a core instead of solid, and to cool the castings as rapidly as practicable from the interior, while retarding the cooling from the exterior, was to diminish the severity of internal strains set up in the cooling masses of metal, and to reduce the period of time required for the establishment of mechanical equilibrium in the castings. My old friend, the eminent chemist, Thomas Graham, who was Master of the Mint when this subject was under examination by me, wrote me a very interesting letter in October, 1865, on the subject of his experience of the tendency to the development of cracks in steel dies; and after mentioning that eight dies out of 200 which had been stored, after having been passed as thoroughly sound, had recently been rejected as having developed cracks, he stated that they had sound reason at the Mint for believing in one peculiarity of tempered steel dies, namely, that if kept in store for a year or two, they became less apt to crack when in use, and coined more pieces than dies newly tempered. The possible existence of internal strains in masses of steel composing the tubes or barrels in which it may be said that the real life of a gun is centered (whether the external portions consist of rings or of coiled wire) is obviously of vastly graver consequence, as affecting the stability of the gun, than the possible effect of a similar condition of things upon the efficiency of particular projectiles, and the importance of guarding against such a source of instability in the individual masses of which a gun is built up cannot be exaggerated. Since steel was first adopted as the material for the inner tubes or chases of our guns, some few casualties have occurred which careful investigation has shown it to be scarcely possible to ascribe to any other cause than the existence in the steel of severe internal stresses, which determined the rupture of the metal when it was subjected to the conflicting strains developed by the action of even very moderate powder pressures. The condition in which the steel might have been, in such instances, when subjected to the action of the exploding powder charge, may be illustrated by reference to the behavior some years ago of the tube of a large gun, in which, after the third proof round was fired, a circumferential crack was found to have become developed in the front threads of the breech screw. Upon removing the jacket from the tube, the crack extended forward along the chamber and into the rifling, and when the tube was placed in the lathe with a view of cutting off the injured portion, the crack suddenly developed itself with a loud report, and ran along to within 8 feet of the muzzle; a spiral crack at the same time ran completely round the tube, which fell in two upon removal from the lathe. The system introduced some years since of tempering, or oil-hardening as it is termed, the several parts of a steel gun, for the purpose of increasing the tenacity of the material, by raising the mass to a high tempera-

ture, and then immersing it in oil, has been demonstrated to result in the development of more or less severe internal stresses in the mass, which can only be removed by subsequent careful annealing; and until this latter practice was largely adopted, instances occurred from time to time at Woolwich, and at other gunmaking establishments, of the fracture of tubes and hoops of guns, either during their treatment in the workshop, or when at rest, or when, in the built-up condition, they have been for the first time exposed to the shock produced by the firing of the gun. One effect which the oil-hardening treatment has occasionally exercised in the case of particular qualities of steel is that of developing minute fissures or cracks in the metal, either superficially or in the interior of the mass. This cannot, of course, be rectified by any annealing process, and it is still a question, to be determined by the teachings of experience and the results of investigations, whether any definite or reliable modifications in the composition of steel used for guns, tending to secure the desired combination of hardness and tenacity, may not be introduced, with the result that a method of treatment of the metal may be discarded which, however

carefully applied, and however efficient the means adopted for reducing or neutralizing its possible prejudicial influence upon the physical stability of the parts of which a gun is built up, carries with it inherent elements of uncertainty and possible danger.—*Sir Frederick Abel.*

A DEVICE TO HOLD BAGS OPEN FOR FILLING.

The bag holder shown in the illustration consists of a frame mounted to revolve, and provided with a number of holders of novel construction, whereby a number of bags may be held in open position for conveniently filling them. It has been patented by Mr. James Davnie, of Hallock, Minn. One of the views shows four bags held open by the holder, another view representing one of the holders in more detail, while the small figure is a side view of the spring-pressed arm of a holder. The bottom of the frame is mounted to turn on a base, in the top of which are rollers arranged in a circle, there being a track on the under side of the bottom of the frame, in the center of which is a pivot pin. In the middle of the frame is a post, from the upper end of which extend a number of horizontal arms, each resting on a separate post at its outer end. Between these horizontal arms are the spaces in which the bags are supported in open position by means of holders on top of the arms. Each holder has a fixed segmental arm and a movable segmental arm, both arms being set edgewise, and each having on its top an outwardly extending flange, over which is passed the edges of the open end of the bag, whereby the latter is supported on the arms. The movable arm of each holder is pivoted at its inner end on the horizontal arm, and its outer end is formed into a handle which slides on a segmental section supported on each of the outer parts. From the handle of each movable holder arm two segmental rods extend outwardly, one rod carrying a coiled spring arranged to draw the arm to its outer-



DAVNIIE'S BAG HOLDER.

most position, or away from the fixed arm, by means of the tension of the spring. The other rod has a collar abutting against a bearing, to limit the movement of the swinging arm. In placing bags in position on the holder, the operator first passes the upper edges of the bag over the flange of the fixed arm, then moves toward it the swinging arm, and passes the other edges of the bag over the latter, the coiled spring then drawing the movable arm backward, holding open the mouth of the bag, and supporting it in position between the two arms. The frame is then revolved for the placing of other bags in position in a similar manner.

THE greatest known depth that oceans have been sounded is over 4,600 fathoms, in the Japan Sea.