

New Inventions.

Norcross's Planing Machine.

We had the pleasure, a short time ago, of examining a beautiful working model of the Planing Machine of N. G. Norcross, of Lowell Mass., which was patented 12th February, 1850. The machine was in the office of Messrs. Stoughton & Harrington, Attorneys, Wall street, this city. We intended to say a few words about it, before this, but owing to so many things coming before us, it escaped our memory, until a friend inquired of us two days ago, if we had ever seen the machine. The cutters of this machine are on a rotary cylinder, but pressure rollers, like the Woodworth machine, are not used. The board is fed in and works along on a table or bench, and the planing cylinder acts upon the board with a rest bar directly above. The planing cylinder and this rest bar may be said to be flexible, as they move vertically together in proper bearings to accommodate their action in unison to the thickness of the board to be planed. The work produced by it is excellent. Owing to the way in which the bed and rest bar are made, the boards are presented to the action of the cutters in a slightly concave surface, this condenses the fibres of the wood and presents a firmer face to the cutters. Knots, and splints, therefore, are not so liable to be thrown out by the cutters, as in other rotary machines.

Double Rotary Grinding Metallic Mill.

Mr. C. W. Van Vliet, of Milton, Ulster Co., N. Y., has invented and taken measures to secure a patent for an improvement on rotary grinding mills, which is well worthy of general attention, because such a mill can be made at but little expense, and it is not liable to get out of order. The mill is double, and has a revolving circular grinder in each case, something it may be said like a large cog wheel and pinion running in two cases, with an opening from the one into the other. The periphery surface of the grinder, which is shaped like a circular stone is serrated, and there is a serrated face with conveying channels on the inside of the case. This is the same in each. The large case is the one where the grain is fed in, and it answers the purpose of a *cracker*. There is a channel into the small case through which the cracked grain is driven and then submitted to the more rapid motion of the small grinding wheel. These grinding wheels can be driven by band and pulley. For farmers, such a mill would be very useful and economical. Messrs. Haviland & Elmer, of Milton, are the assignees.

New Smut Machine.

Mr. Alfred Joplin, of Chesterfield, S. C., has invented and made application for an improvement in machines for cleaning all kinds of grain, which promises to be valuable, as being simple of construction, effective in action, and not easily deranged. There is a conical fluted roller with two or three broad channels extending its whole length, and this roller works in the inside of a perforated metal case. The grain is fed in through this case, and finds its way to the end of the roller, being acted on by the fluted projections spoken of in its passage. This action separates all the smut and impurities from the good grain, and at the channel out of which the scoured grain is passing, it is met by a current of wind which blows away all the impurities of a less specific gravity than the good grain, while the good grain falls down through the current into a proper receiver.

Improved Printing Press.

Mr. Lucius P. Guernsey, of Montpelier, Vt., foreman of the "Christain Messenger," has made some improvements on printing presses and has one on his plan in operation, respecting which he says:—"I am satisfied that a press large enough to work any country paper, would be easily driven at two or three tokens per hour, and with far less motive power than is required by Adam's improved press. And I am further satisfied that, as a regular business, they can be made in a thorough substantial manner, and sold at five hundred dollars—complete in blanketing, roller moulds, &c."

IMPROVED SEED DRILL.

The accompanying engravings, represent improvements on a seed drill, by Messrs. Lyman, Bickford, and Henry Huffman, of Macedon, Wayne Co., N. Y., who, as we stated three weeks ago, had taken measures to secure a patent for the same. Fig. 1 is a perspective view. Fig. 2 is a plan of the distributing seed cylinder, and slides detached. A is the hopper for receiving the seed. B is a gear wheel on the end of the distributing seed cylinder, which is made to revolve on fixed bearings; C is another gear wheel on the outside axle of the carriage; D is a small intermediate wheel secured on a swingle lever, E, to gear the wheel, B, with the axles, so as to give

motion to the seed cylinder, or throw it out of motion by working the lever, E. F is a shaft extending across the frame behind, and is worked by the lever extending up behind the hopper; I I I are seed tubes or spouts. They extend from the underside of the revolving seed cylinder to the ground. Each one is secured to a metal band around the shaft, F, being connected by a chain to an arm on the band. There is a small handle to each band also, by the turning of which a single spout can be raised as desired. By turning the large handle of the shaft, F, downwards, all the spouts will be lifted at once above the ground. The spouts (each one) are made

Figure 1.

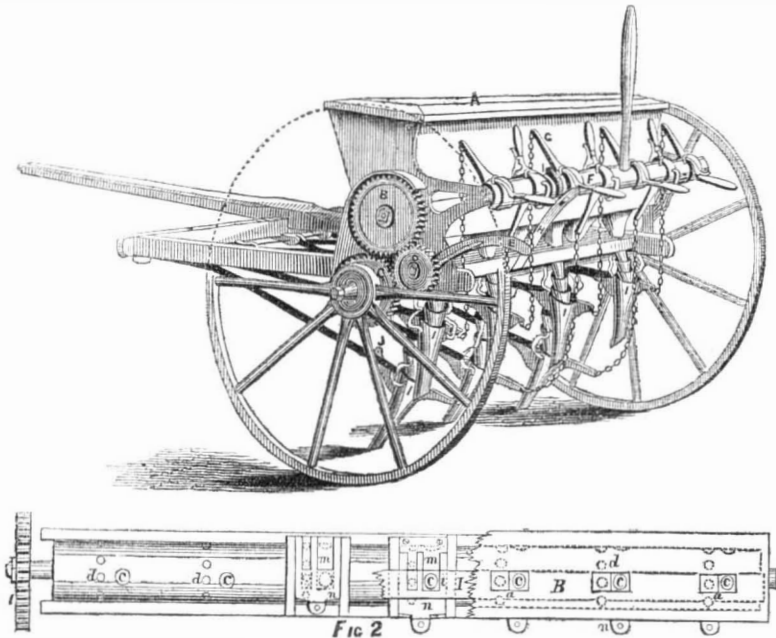

in sections, one section is made lapping over the other, and united by a flexible connection, such as a piece of leather. This arrangement makes them lap up over one another when the chains of the collars are raised to lift the spouts above the ground. H is a catch rod, which has a slot in it to slip over a button on the shaft, F, and retain it in any position, so as to keep the tubes stationary when lifted up. These tubes or spouts are suspended on levers extending from the front, and the chains behind are only for lifting them up. One of the suspending levers is represented by J.

By reference to fig. 2, we would state that the distributing cylinder revolves under the fixed bottom, B, of the hopper, A, fig. 1. The cylinder receives the seed from the hopper through slits, *a a*, in the bottom of the hopper, and between the hopper and cylinder is a space wherein a slide, I, having also oblong slits, *i*, in it, is made to close or open communication between the hopper and the distributing cylinder. The seed passes into the cylinder by the holes, *c*, and *d*, the latter being smaller and more close together than the former for small seed; *b* is the end of the seed cylinder shaft. This shaft may be provided with various gear wheels, to give the cylinder any required speed. Under the bottom of the hopper, (every two rows, *c, d,*) is a pair of

metal plates, one, *m*, with a pair of holes in them situated over the other holes, *c, d*, and the other, *n*, sliding in rebates on *m*, to close or leave open the holes in the said plates. These slides are worked behind by rods, so that the seed can be shut off from any one spout—a very convenient and useful arrangement.

The seed passes from the hopper through the slits mentioned into the revolving cylinder through the holes, *c*, and *d*, and then through the same openings the seed is deposited in the spouts when the cylinder holes revolve to the under side. By gearing the revolving cylinder with the axle, various speeds can be given to the distributing cylinder, to vary the amount of seed for any given quantity of ground to be sown. The seed can be let on and shut off from any one spout. One spout can be lifted, or all can be lifted at once as required, all the seed can be shut off at once from passing from the hopper by the large top slide. The spouts are hung in a fine manner on the levers, J, spoken of, so that one or any number of spouts may be taken off at any moment by drawing out a pin. This makes the machine very convenient and valuable; its whole construction and operation appears to be complete in every respect.

More information may be obtained of the inventors by letter.

MACHINERY FOR MAKING HAT BODIES.—Figure 1.

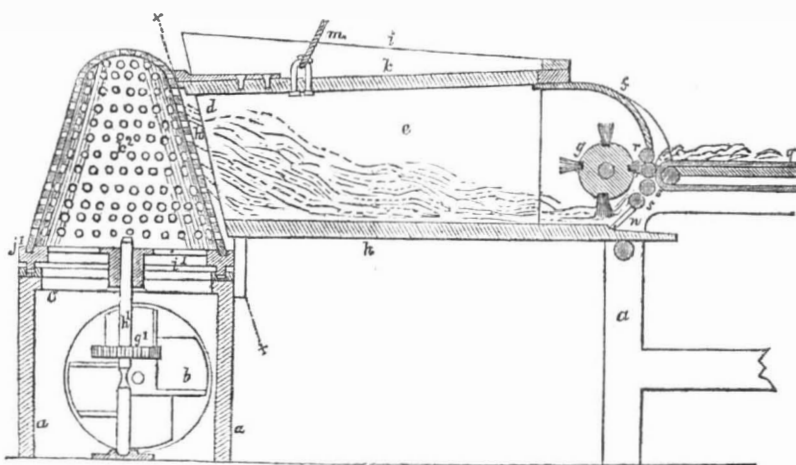

This is the improved American machinery employed in the building at Hague street, this city, at the time of the dreadful explosion in

the early part of last year. It has recently been patented in England, and described in "Newton's Repertory of Inventions," the patent having been received by and in the name of W. E. Newton, Esq.

Figure 1 is a longitudinal vertical section; figure 2 is a vertical section with a bat wrapped around with a felt cloth. Figure 3 is a view of the perforated cap. Hat bodies are made of fur and fine wool, and are not woven but felted; they are made of the desired shape by a very scientific process. The principle employed is a vacuum process, which makes the wool fly on to a perforated cap, in the inside of which revolves a fan, and the wool sticks on this cap, it revolving all the time until a felt is formed on the said cap of sufficient thickness to form the hat body. Figure 1 shows the whole operation: *a a* is a frame; *b* is an exhausting fan revolving in a chamber, *c*; *K* is what is termed a *former*, it is made of thin copper and perforated; *e* is a trunk, with an aperture, *d*; this trunk is connected with the case, *f*, in which is a rotary brush, *g*. The trunk bottom, *h*, is flat and is inclined towards the mouth; *i* is one of the sides of this trunk, it is made of thin sheet copper, capable of being easily bent to change the shape of the mouth, *d*, easily, so as to direct more or less of the wool on any part of the hat on *K*. The top, *k*, of this trunk is flat; it tapers conically towards the mouth, *d*. The back part of the trunk, between the bottom and lowest of the rollers behind the brush, *g*, is open for the admission of air, which flows towards the exhaust inside of the *former*; this aperture is represented with a regulating valve, *n*, to regulate or stop the current. The fibres of wool are fed to the brush from an apron, *q*, by the feeding rollers, *r r*, which are covered with cloth; below these are other two rollers, *s s*, against which the fibres are brushed; these feed rollers receive motion by a belt from other machinery. The exhaust fan, *b*, also receives rapid motion by gearing driven from a main shaft (not shown); *g'* is a worm wheel on a vertical shaft, *h'*; this shaft has an arm, *i'*, which carries a grooved rim, *j'*, into which groove is fitted the lower edge of the perforated *former*. The *former* should fit snugly in this rim, air-tight, but yet be easy of removal. The fur is spread on the apron,

FIG. 3. FIG. 2.

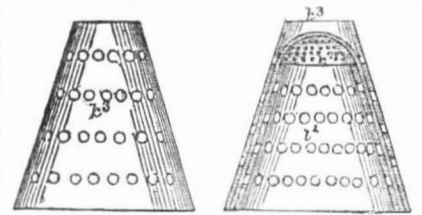

which gradually supplies it to the feed rollers. The brush, *g*, throws the wool forward, and it flies on the *former* and sticks to it. At the commencement of the operation the valve, *n*, is kept close, to check the force of the current, until a film of fibres is laid on the *former*, when the said valve is gradually opened. As soon as the required thickness of bat has been obtained, the operator takes a wet cloth, wraps it around the bat, and takes off the *former* and the bat on it. A metal cap, *K*, is put over the felt covering, and then a shield, *l*, fig. 2, placed inside within the *former*, and then the whole, as shown in section, fig. 2, is immersed in hot water to harden the bat. The holes admit the water freely to the bat, and the shield, *l*, prevents the *former* from collapsing, when the whole is drawn out of the water. While the hardening and taking off process is going on, another *former* has been placed on the arms, *j'*, and another felt is forming. To witness the operation, the wool begins to cover the *former* like a mist, and gradually the hat body assumes shape and is formed.

Messrs. Taylor, of this city and Newark, N. J., are the owners of the patent.

The Galignani says that a doctor died in France, who, when his effects came to be examined, turned out to be a person named Patison, once a great robber in Vermont. It speaks of his lame leg, and we infer from it, that it is a revamped story of old Capt. Thundebolt.