

# Scientific American.

THE ADVOCATE OF INDUSTRY, AND JOURNAL OF SCIENTIFIC, MECHANICAL AND OTHER IMPROVEMENTS.

VOLUME 6.]

NEW-YORK, APRIL 12, 1851.

[NUMBER 30.

THE  
Scientific American,  
CIRCULATION 16,000.

PUBLISHED WEEKLY

At 136 Fulton, street, N. Y., (Sun Building,) and  
13 Court street, Boston, Mass.

BY MUNN & COMPANY,

The Principal Office being at New York.

A. T. Hotchkiss, Boston.  
Dexter & Bro., New York City.  
Weld & Co., New Orleans.  
Stokes & Bro., Philadelphia.  
Cooke & LeCount, San Francisco, Cal.  
Courtenay & Wienges, Charleston, S. C.  
John Caruthers, Savannah, Ga.  
Barlow, Payne & Perken, London.  
M. M. Gardissal & Co. Paris.

Responsible Agents may also be found in all the  
principal cities and towns in the United States.

TERMS---\$2 a year---\$1 in advance and the  
remainder in 6 months.

## Rail-Road News.

### The Erie Railroad.

The construction of this work will be completed by the 15th of this month. In anticipation of the opening of the road, the Directors of the Company have made arrangements to ticket passengers and check baggage through to Chicago, Detroit, Cleveland, Toledo and other places on the lake. On the arrival of the trains, the steamers Chicago, Queen City, or Keystone State, of the Detroit line; the Empire, Saratoga or Alabama, of the Cleveland or Toledo line, will be in readiness to convey passengers directly through to those places. The steamers Albany, Diamond, and Fashion will also form a line between Dunkirk and Cleveland, landing at the intermediate ports. These steamers are all first-class vessels, are fast sailers, and have superior accommodations. When these arrangements are completed, it is intended to convey passengers from this city to Dunkirk in sixteen hours, (night line eighteen hours;) to Detroit in thirty-six hours; to Cincinnati in forty hours, and to Chicago in forty eight to fifty hours.

The benefits which these arrangements will confer upon the travelling community cannot be estimated, and the Company are entitled to great credit for the enterprise they have exhibited.

The Irishmen on the Attica and Hornelsville Railroad, in western New York, struck for wages last week, and on Monday one or two men were killed by them.

### From California.

The steamship Empire City arrived at this port on Tuesday, bringing one million in gold dust and 250 passengers. On the evening before, the Georgia arrived.

The construction of the Panama Railroad was progressing, and there was no sickness on the Isthmus.

Lynch law had been administered in Sacramento City upon a man named T. J. Roe, for murder.

The quartz gold rocks are being worked with great success by machinery.

The gold diggers had been very successful, but it had been very cold on some parts of the mountains. The returns of gold from California, have not as a whole been equal to the amount sent out there in the shape of dry goods, provisions &c. Good returns will no doubt yet be forthcoming.

The State of California is one of the most extraordinary creations that we have any account of; in fact there has never happened such another movement, so far as we have been able to learn. More attention is now being directed to agriculture, but around San Francisco, the climate is not very healthy.

The great question now is, when shall we have a railroad to the Pacific.

## IMPROVEMENT IN WIND-MILLS---Fig. 1.

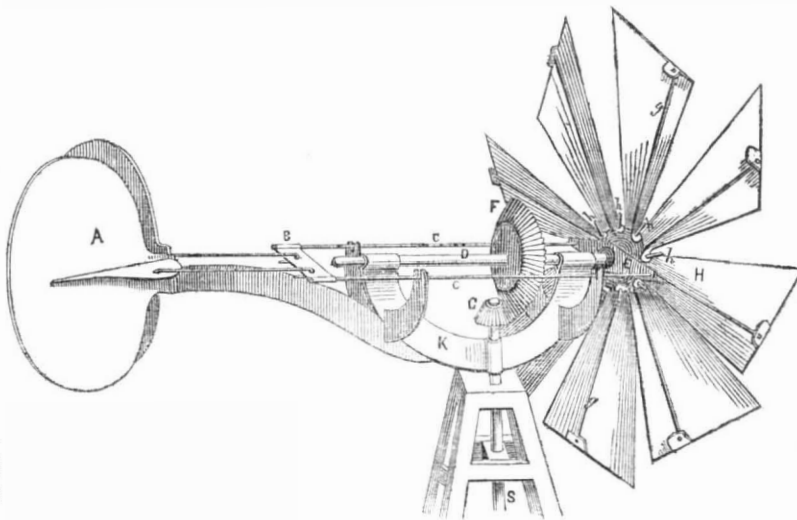

This improvement in Wind-mills relates to a superior mode of governing the vanes according to the velocity of the wind. It is the invention of Mr. Marvin Smith, of New Haven, Conn., who has taken measures to secure a patent for the same. Figure 1 is a perspective view, and figure 2 is a plan view:—the same letters refer to like parts.

The wind-mill is represented as built upon a frame, with a vertical shaft, S, extending down; this frame may be erected in a tower or building in the inside of which is the machinery to be driven. The power is taken from the shaft, S, which may have a gear wheel on it below, or else a large pulley, and the power transmitted by belting. A is a double fan, which perform the office of a "governor." Each has a separate vertical axis, so that they can spread out or be moved close together; each one has a flange on its side from which a rod extends to a cross bar or plate, B; C C are two rods attached to this cross-bar. They are supported on curved arms, and extend to and

FIG. 2.

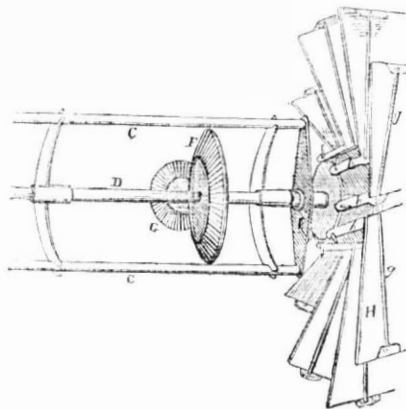

are united, as represented in figure 2, to another cross-bar, E. This latter cross-bar is secured on a collar which surrounds the driving spindle, D, of the wind-mill. The collar is close to the neck and has a disc or round plate behind the hub of the vanes or sails; H represents a vane or sail; each one is secured on a spindle, g, which spindle is placed on the back side, out of line with the centre of each vane, and with the inner end inserted in a central hub to turn in the same in a bearing (a bearing for each spindle). Between the hub and the disc of the collar behind it, there are springs of steel. Each vane, H, has a small curved flange, h, (with an opening through it for the spindle, g), which is united to the disc of the bar, E. Each curved flange has a perforation through its inner end, through which an axis on the disc passes, so that each vane is attached separately to the said disc, but all

move simultaneously together. The shaft, D, is secured in the centre of the hub and revolves in bearing collars on the crescent arms, K, which can be turned round to any point of the compass as it is supported on the vertical shaft, S, by surrounding the said shaft with a collar. It is necessary that this should be easily done to present the vanes to the wind in any quarter. F is a bevel gear on the driving horizontal shaft, and G is a smaller gear on the vertical shaft; it will therefore be understood how motion is communicated to the shaft, S. The vanes of this wind-wheel are self-regulating.

The stiffer the breeze, each vane by its axis being out of line, turns its edge more and more to the gale, while at the same time, the whole of the vanes may be turned with their edges outwards by spreading the fans, A A, which thereby push the rods, C C, and their cross-bar E, close up to the hub. As the edges of the vanes are turned outwards, the said rods, by the curved flanges, h h, are pushed back and the fans closed. The springs between the hub and disc, and the flanges, h h, allow the shaft, D, to be moved so as to ungear the bevel wheel, F, from the other, G.

The motion of this wind-mill can be very easily controlled. All the machinery will be covered in. It can easily be rendered portable so as to be carried in a wagon from one place to another. It is adapted to all purposes for which power is required. The inventor designs to erect one on a truck, with wheels, so as to be moved at will: it can be used for driving grinding machinery and other kinds, and may be very useful for farmers, for sawing wood, pumping, &c. On the wide and extended prairies of the West, it appears to us, this wind-mill would be of immense benefit.

More information may be obtained by letter addressed to the inventor.

### New Motive Power.

An engine has been completed in the American Machine Works, in Springfield, in which air takes the place of steam as the expansive force. It is to be sent to the World's Fair. It is said to work well, and shows that air can produce the same effect as steam, with one-twentieth part of the fuel, and less danger of explosion. A patent has been secured. If all this be true, the inventor must have found some new way of making available a force which has often been tried before with no success to be compared with steam power.—[Exchange.

[Let any one turn to volume three, page 134 and 142, and he will find that the above is nothing new as an application of hot air, but

it is about the fuel. We do not believe a word about the economy of the fuel. We have never heard of the patent being secured either—never have noticed it in any of our lists of claims. More than one hot-air engine is described in Hebert's History of the Steam engine.

### Keep Your Back Warm.

About 20 years ago, I read a medical treatise which stated "that the back is the most valuable part of the human system through which most of the colds enter."

Recollecting that when I took cold suddenly, I noticed that my back was generally cold, I had my waistcoat cushioned along the back, 6 or 8 inches wide, since which time I have not taken cold one quarter as often as before. Several who have tried the experiment at my suggestion, have informed me that in their opinion, they have been materially benefitted thereby.

The philosophy of it is; that by putting more clothing along the spine than elsewhere, other parts become chilly first, and warm to guard against taking cold, while the increased clothing at the same time prevents such a sudden change of temperature. Take care—coming from the back is generally too late, the cold have already become seated.

I hold that cold and damp feet cause many colds, because they induce to chill the back, more than because they cool the extremities.

None of all the lower animals the Lord has clothed has less clothing on the back than upon other parts of the body. To me it looks frightful to see so many delicate persons go with their backs and feet half clothed. But while hosts are cracking up for agricultural societies and bureaus to improve the breed of our domestic animals, the favored of the people are worshipping the great moloch of fashions and sacrificing upon his shrine multitudes of the choicest portions of our race.

C. RICH.

### Cold Water for Burns.

Fowlers & Wells recommend the application of cold water as a cure for slight burns. This I tried with the following success. My little girl, 2 years old, fell from a dining chair upon the top of a cooking stove heated almost to redness with coal. One half of her face was burned to a blister, and one arm the same. Cold water was immediately applied with linen cloths, the child ceased crying, and soon fell asleep and apparently suffered no great inconvenience from it afterwards. This was more than a year ago, and there is not even a scar left to tell where the burn was.

G. L. F. BAILEY.

Two Chinese merchants, Ahung and Ry have arrived at Berlin on their way to England, to visit the exhibition. They have preferred the overland journey, through Russia, to the sea voyage which some of their associates are making in a junk.

### Cincinnati for Pork Hams.

The Gazette states that nine men of that city recently canvassed 3,408 hams in nine hours. We think this a decidedly preferable and more honorable business than canvassing for voters. The canvassing is nothing more than covering the hams with cloth.

A ship Wm. Bathbone, left Savannah on the 1st inst., with the immense cargo of 2,897 bales of upland and 445 bales of sea island cotton.

Mr. Mitchell, an Edinburgh, Scotland, engraver, intends sending to the exhibition a piece of gold so small that an ordinary pin's head will cover it; yet it contains the whole of the Lord's prayer.