

Scientific American.

THE ADVOCATE OF INDUSTRY, AND JOURNAL OF SCIENTIFIC, MECHANICAL AND OTHER IMPROVEMENTS.

VOLUME 6.]

NEW-YORK, DECEMBER 28, 1850.

[NUMBER 15.

THE
Scientific American,
CIRCULATION 16,000.

PUBLISHED WEEKLY

At 128 Fulton, street, N. Y., (Sun Building,) and
13 Court street, Boston, Mass.

BY MUNN & COMPANY,

The Principal Office being at New York.

A. T. Hotchkiss, Boston.
Dexter & Bro., New York City.
Weld & Co., New Orleans.
Stokes & Bro., Philadelphia.
Barlow, Payne & Parken, London.
Responsible Agents may also be found in all the
principal cities and towns in the United States.

TERMS---\$2 a-year---\$1 in advance and the
remainder in 6 months.

Rail-Road News.

National Road to the Pacific.

Senator Benton has introduced a Bill into the Senate, for the construction of a great National Road to the Pacific. The Bill has been read twice and referred to the Committee on Roads and Canals, and ordered to be printed. The leading features of this Bill are, that "a district of territory, 100 miles wide, and extending from the western frontier of Missouri to the Pacific Ocean, and corresponding to the central latitudes of the United States, shall be set apart and reserved for opening communication with California, Oregon, New Mexico, and Utah"—the road to run from St. Louis to the Bay of San Francisco, with branches to Oregon, Santa Fe, and the Great Salt Lake—the branches only to have 50 miles wide reserved strips for their construction. This road is to be constructed by Government, and to be free from all monopoly of individuals, and to be free, to all intents and purposes, for ever, to our citizens, who are not to pay any more toll than what will pay the road expenses. There are to be three roads constructed—one a railroad, one a wagon or carriage road, the other for foot passengers, and a strip to be reserved for a line of telegraph. The bill proposes that the work shall be commenced at once, after due reports have been made on the best route, and that government shall advance money (\$300,000) to commence the work, but the lands set apart are ultimately to pay the whole expenses.

In introducing the Bill, Mr. Benton made some capital remarks on the same, and presented much important information. He said that there were plenty men in the West, the hunters, who knew every foot-way of the road, and by employing them, they could stake it out "as fast as a horse could trot." "There is an idea, he said, "become current, of late, that none but a man of science, bred in school, could lay off a road—that is a mistake: there is a class of topographical engineers older than the schools, and more unerring than the mathematics. They are the wild animals—buffalo, elk, deer, antelope, and bear. They traverse the forest not by compass, but instinct, which leads them always the right way to the lowest passes in the mountains, and the shallowest fords in the rivers—the best pastures, the salt springs, and the shortest practicable lines between any two points—they travel thousands of miles and never miss the best and shortest route. They are the first engineers to lay out a road in a new country, the Indians follow them; then the white hunters in pursuit of game, then the buffalo road afterwards becomes the wagon road of the white man." Col. Benton has been informed, by hunters, that there is a way for a direct road to the Pacific. He stated that the National Road over the Alleghenies,—the military road of Gen. Braddock,—was an old buffalo path, so was the other National Road down the Valley of the Kenhau-

IMPROVED SHIPS' WINDOWS---Figure 1.

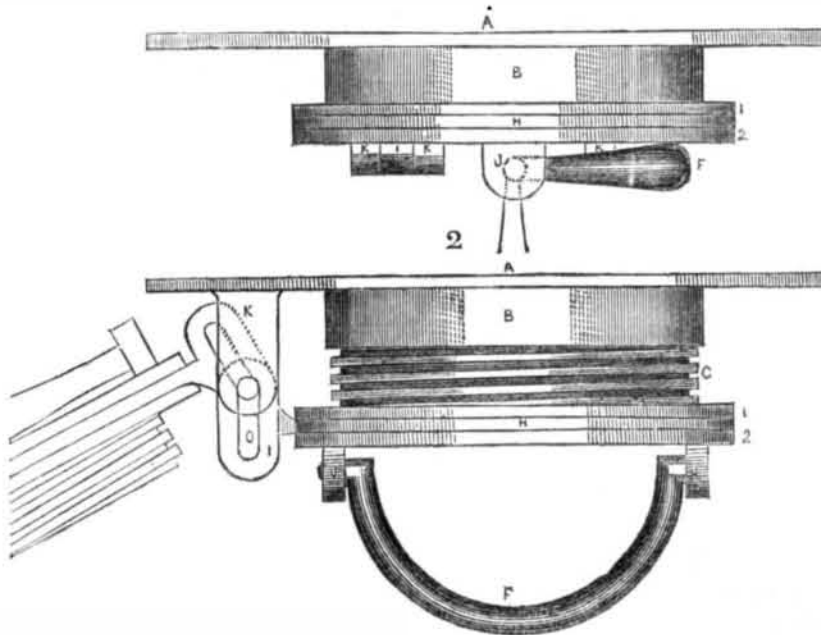

This improvement is the invention of Mr. Leonard Goodrich, No. 636 Water street, this city, who has applied for a patent.

Figure 1 is a side view, with the window screwed close down. Figure 2 is a side view, showing the screw of the window, also a part of it thrown open to show the slot in the hinge. Figure 3 is a plan view, or as the window appears when closed, to a person looking on the side of a vessel. The same letters refer to like parts.

The old ship windows were fastened by hinges to the metal flange of the window tube, and they were held by bars or bolts. This invention secures the window by a screw, fitting into the window butt, and it has hinges

the same as the old window, but these are made with a slot, to allow the window to be screwed out and in. A is a metal flange secured to the vessel by bolts; B is a tubular butt attached to the flange, A; this butt has a thread cut on it, inside, like the butt of a hose; C is a screw on a tubular part of the sliding window, 1 2, are circular ring plates united together inside. The glass, D, is in the inside one, and the outside one, E, holds the glass. The screw is part of the ring, 1. H is another ring plate, which is held in a recess formed between the plates, 1 2. This plate, H, branches off with flanges at the back, as shown in figure 3, which terminate in hinge eyes, or loops, I L. On the flange, A, are other pro-

Figure 3.

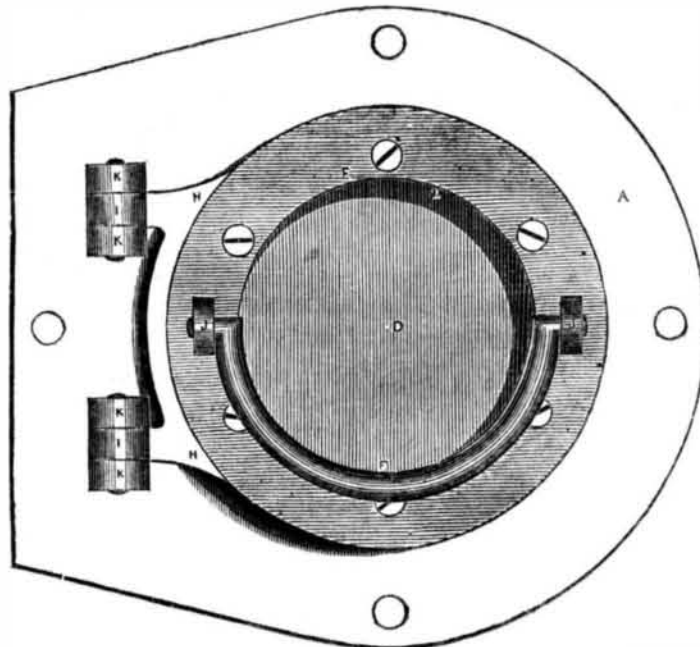

jecting stationary hinge loops, K K K K. A Pivot or stud passes through the loops, as represented in fig. 3, thus forming the two huge joints of the window. The flange, H, has an elongated slot, O, in it, as shown in figure 2, (that part shown in section.) It will be seen that when the screw is screwed in by the handle F, the ring of the flange, H H, will not turn round, but will be merely raised up or pressed down by the act of screwing the window into its butt. The slot, O, allows the hinge or loop, I, thus to work on its stud or pivot. The lid or cover, with the light, has three motions—one round about, the other out and in (re-

ciprocating) and the other to turn outwards and inwards on the pivots of the hinges; J J are box bearings for the handle, F.

This improvement is a good one; every person acquainted with the working of ship windows, who has seen it, has spoken favorably of its qualities. It must take, because it is doubly secure. The hinges might be broken off, or the pivots injured, yet the window would be as fast as ever in its seat.

Persons wishing more information can obtain the same by letter, addressed to Mr. Goodrich, directed as above, who will promptly answer the same.

Preparatory Size.

Boil a handful of the leaves of wormwood and two or three heads of garlic in a quart of water, until the liquid is reduced to one-half; then strain it through a cloth, and add half a handful of common salt, and nearly half a pint of vinegar. The design of this composition (usually employed in gilding looking-glass and picture frames) is to obviate the greasiness of the wood, and prepare it the better to receive the coats which are to be laid on, and to preserve it from the ravages of the worms. When used, it is mixed with a sufficient portion of good glue, boiling hot. In applying it to the gilding of plaster or marble, the salt must be left out of its composition; as, in damp situations, this would produce a white saline efflorescence on the surface of the gold.

Gold Water Size.

One pound of Armenia bole, two ounces of red lead, and a sufficient portion of black lead, are ground separately in water, and then mixed, and re-ground with nearly a spoonful of olive oil. The gold size is tempered by mixing it in parchment size which is clear and clean, and has been passed through a fine sieve to clear it of all foreign matters. The parchment size is made by boiling down pieces of white leather, or clippings of parchment, till they are reduced to a stiff jelly.

White Coating.

A quart of strong parchment size and half a pint of water are to be made quite hot, and to this are to be added (in small portions from time to time) two good handfuls of common whitening passed through a fine sieve; this mixture is to be left to infuse for half an hour, when it is to be stirred carefully so that the amalgamation may be perfect.

Coloring Yellow.

Half a pint of parchment size is taken, which must be clean, white, and clear, and of one-half the strength of that used for the white coating; this is warmed, and there are mixed with it two ounces of yellow ochre, very finely ground in water; it is then left at rest, and the clear portion decanted, which gives a fine yellow color, that serves, in water gilding, to cover those deep recesses into which the gold cannot be made to enter; it serves also as a mordant for the gold size.

Vermeil.

This is a liquid which gives to the gold a warm reflection. It is composed of two ounces of annatto, one ounce of gamboge, one ounce of vermilion, half an ounce of dragon's blood, two ounces of sal of tartar, and eighteen grains of good saffron. The whole is to be boiled in a quart of water, over a slow fire, until it is reduced to one-fourth, when the liquor is passed through a strainer of silk or muslin.

Gold Color or Oil Size.

The English method of preparing the color in size, which serves as the ground on which the gold is laid, is to grind together some red oxide of lead with the thickest drying oil that can be procured—the older the better. To make it work freely, it is mixed before being used with a little oil of turpentine, till it is brought to a proper consistence.

To Light Matches in Damp Weather.

It may be useful to our readers to know that matches when too damp to be used in the ordinary way, can be ignited by rubbing them gently, for a few seconds, upon a piece of cork.

Water contained in old cisterns, if it be covered, and some years old, is better than new water.