

AN IMPROVED PADDLE-BELT.

A special construction of an endless belt armed with paddles, and adapted to run over end pulleys, to give a long, straight stroke in the water, in propelling vessels, is illustrated herewith, and has been patented by Mr. William H. Silsby, of Martin's Ferry, Cal. Beneath the ends of each paddle the belt is bent to the curve of the pulleys, and to this curved portion are riveted or

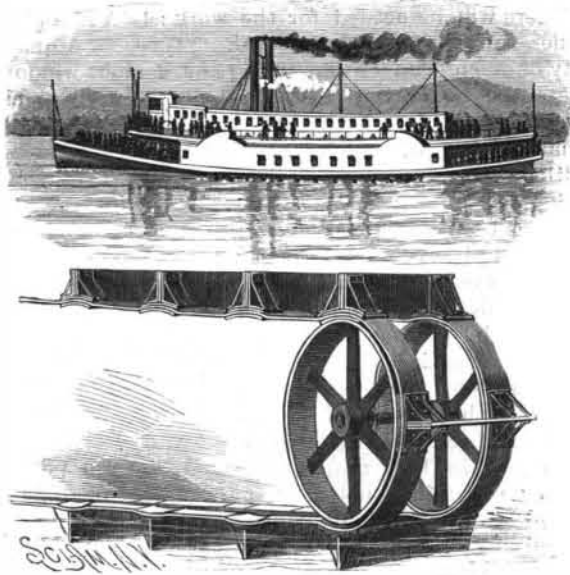

SILSBY'S PADDLE-BELT.

otherwise secured rigid plates, in the shape of cylindrical segments conforming to the pulleys, these plates serving as a base for the rigid attachment of paddles, while causing the bands in passing over the pulleys to embrace them as they would if wholly flexible. The paddles have their feet riveted to the middle part of the plates, and are further strengthened by inclined braces having their other ends secured to the outer ends of the plates, whereby they are firmly held in a position perpendicular to the bands. The straight draught of such a paddle belt gives a large hold on the water, and, where two of them are used on the bottom of a boat, great facility in turning is afforded by running one backward and the other forward.

AN IMPROVED GATE.

The illustrations herewith represent a patented gate of the Pearl Gate Company, of North Lansing, Mich., one of the views showing the gate elevated to allow small stock to pass under. A heel post is attached to the hinge post by means of an eye and staple hinge, and the upper and lower rear corners of the gate are provided with brackets, the upper one of which has an anti-friction roller which bears against the outer face

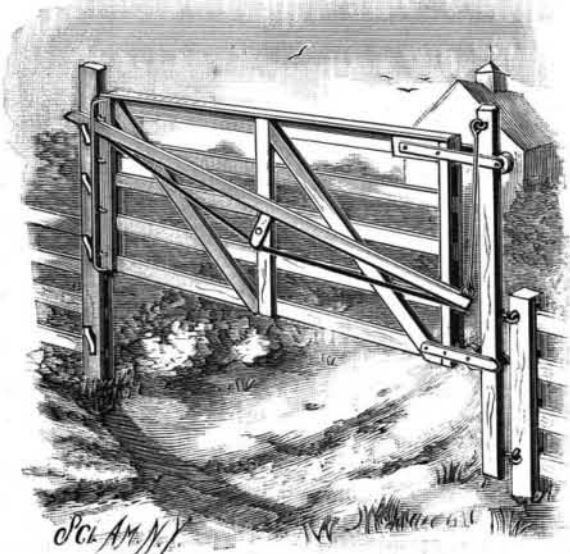
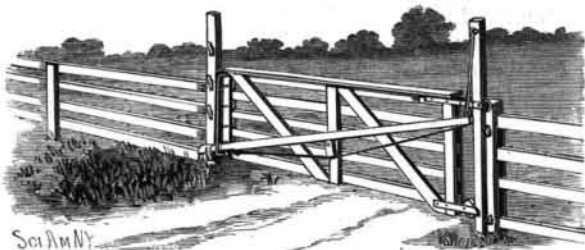

A LIFTING AND SWINGING GATE.

of the heel post, while the lower one has a similar roller bearing against the inner face of the heel post, these brackets loosely embracing the heel post, so that the gate can be readily raised and lowered. At about the center of the gate a lever is fulcrumed, its rear end being supported by a link from the upper end of the heel post, while the front stile of the gate has a series of staples, and a guide rod or bracket, between which and the gate the free end of the lever projects enough to overlap the latch post, having stops at varying heights, these stops being at different heights from the staples on the gate. As the weight of the gate is sustained by

the lever, it is provided with a truss rod, whereby it may be made lighter. When the free end of the lever rests upon any one of the stops on the front stile of the gate, the latter is prevented from sliding down to the ground, and may be swung upon its hinges. When the gate is closed, the lever should be detached from its rest and allowed to drop to its lowest position. The gate automatically latches itself as the free end of the lever strikes the latch post, the lever being thus thrown off from the stop on the outer stile of the gate, and being caught on the stop of the latch post next below. If it is desired to hold the gate in a higher or lower closed position, for allowing small stock to pass under, such adjustment is readily obtained by placing the free end of the lever in one stop or another, thus moving the gate vertically.

A Four Million Dollar Ship.

A great sensation was recently made at Newcastle-on-Tyne, when the new war ship Victoria was slowly towed from Elswick, down the river and out to sea, by seven steam tugs. The river banks were lined with people on both sides at all the more important centers of population. The voyage was accomplished without any hitch. At the Swing Bridge there were very few inches to spare in the width of the opening, and at one time fenders had to be used to soften down a slight collision. In crossing the bar, thanks to the work of the Tyne commissioners, there was plenty of depth of water, notwithstanding the heavy draught of the enormous vessel. On reaching the open sea several hours elapsed while the compasses were being adjusted, and then the vessel, propelled by her own engines, was quickly out of sight. On arriving at Sheerness, she was taken in charge by the Medway Steam Reserve authorities. Some time will elapse before she is fit for active service, but no efforts will be spared to finish her as soon as possible. Her cost to the country will be over \$4,000,000.

AN IMPROVED APPARATUS FOR EXAMINING ORES.

An apparatus for examining rocks, to determine whether they contain metallic ores, has been patented by Messrs. John R. Williamson, of Seattle, Washington Territory, and William W. Hickies, of Oakland, Cal., and is illustrated herewith, one view showing the examination thereby of rocks *in situ*, and the other representing the examination of detached rocks. One pole of a battery is connected with one terminal of a telephone receiver by means of a wire in the usual way, the remaining pole of the battery being connected by a conductor with a brush provided with a suitable handle, while the remaining terminal of the telephone receiver is connected by a conductor with a similar brush having a like handle. In examining rocks in place, the two brushes forming the terminals of the conductors connected with the telephone and battery are drawn along the face of the rock, while the telephone is held to the ear of the operator. If the rocks contain metals they conduct the current, and the movement of the brushes along the rough face of the rock causes variations therein, which are audible through the telephone, there being no sounds produced when the rock contains no minerals. In examining detached portions of rock, the latter are placed upon a conducting plate connected with the telephone through the battery, and the brush at the other terminal is touched to the rock, which, if it contains metal or metallic ores, will cause sounds to be heard in the telephone. Instead of using the conducting plate, the fragments of rock may be examined by being placed upon insulating material, and bringing both brushes in contact with each specimen. Other means of indicating the passage of the current may be employed instead of the telephone receiver, as the operator may place the conductors on his tongue and note the sensations due to the completion of the circuit, or a galvanometer may be employed, or a paper saturated with salt, which will be decomposed by the current, making marks on the paper, although the telephone receiver is preferable from its portability and effectiveness and the ease with which it is managed.

For further particulars with reference to this invention address Mr. John R. Williamson, Seattle, Washington Ter.

A COMBINED TIE, CHAIR, AND FISH PLATE.

A novel construction of tie, chair, and fish plate combined, for holding railway rails in position, and clamping them to the ties, is illustrated herewith, and has been patented by Messrs. Daniel Harrington and Morris A. Keane, of No. 149 Albany Street, New Brunswick, N. J. The chair has a com-

pound recess, in one division of which [the rail fits, as shown in Fig. 2, while in the other division forms a horizontal member of an angular fish plate having its under surface partially conformed to the contour of the rail flange and partially concave, its vertical member being also concave on its inner bearing surface. The means for binding the fish plate to the rail and to the chain will be readily seen from the sectional

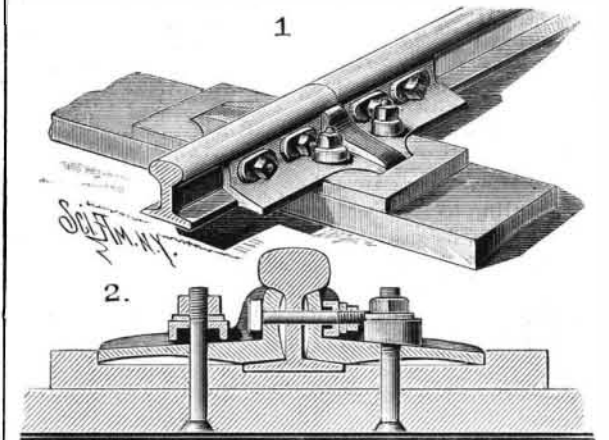

HARRINGTON & KEANE'S CHAIR AND FISH PLATE.

view, the under surface of the sleeper being concave. When the device is applied simply as a chair for clamping rails at any part of their length, the construction is similar, except that the vertical member found in the fish plate is omitted. The sleeper may be made of any suitable material, but iron is preferred.

AN IMPROVED FRUIT JAR.

A fruit jar combined with an adjustable ring to complete or form the sealing groove for the cap is illustrated herewith, and has been patented by Messrs. John B. and Robert Johns, of Massillon, Ohio. The jar has a sealing surface blown or formed on the outside of its neck, in such way that it will not have to be taken back to the furnace to form the rim or groove. The cap is preferably made of thin metal, and made to



JOHNS' FRUIT JAR.

slope downward and outward on the exterior of the neck to a point below which is an annular groove, wherein the wax or sealing composition passes under the edge of the cap in closing the jar. The adjustable ring which forms the sealing groove for the cap inclines outward in an upward direction when in place, its ends being preferably made to overlap one another, and the outer end bent outward to form a lip for convenience in opening the ring, which is a spring one, self-adjustable to the jar. The ring is applied to the jar after the latter has been charged with fruit or other contents, the cap being then put in place and the sealing composition subsequently filled in. To unseal the jar the ring is first removed, thereby exposing the wax or sealing composition so that it can be readily knocked or picked off.

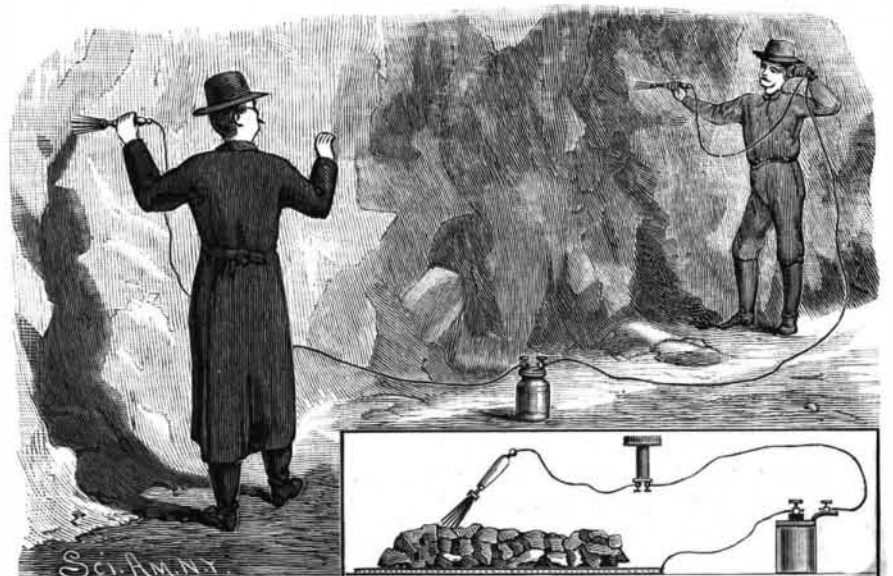

WILLIAMSON & HICKIES' APPARATUS FOR EXAMINING ORES.