

## New Inventions.

### Improvements in Carding.

Messrs. J. Lambert & J. Zimmerman, of Waterloo, N. Y., have made an improvement in the working of Carding machines, for which they have taken measures to secure a patent, and which is said to card double the quantity at least, in the same time, than has usually been done by the old mode of operation. The "Workers," instead of carrying round the wool from the main cylinder, at once, by revolving in a contrary direction, revolve with it, and carry the wool but a short distance to the strippers, and thus, by the way, they are geared; the "workers" are rendered workers indeed, and not merely in name.

### Tapestry, Velvet, and other Carpets.

Mr. James Templeton, of Glasgow, Scotland, has taken out a patent in England for an improved method of manufacturing carpets, the designs of which are produced from the weft threads, which are previously printed to produce the design or pattern. He makes velvet carpets by employing *chenille* weft, previously printed, which weaves up into the patterns designed; he also makes carpets by the printed weft, which work up into patterns on both sides of the carpet, like those of the ingrain carpet. The principle of this important improvement in carpet weaving to do away with the *jacquard*, lies in the mode of printing and preparing the weft, previous to weaving.

### Scientific and Mechanical Information.

More than ever, our attention for the future will be devoted in procuring the latest and most important information from all parts of the world, respecting new and useful improvements and discoveries. Our correspondent in London, of whom we spoke a few weeks since, will impart interest to our columns, by his reviews on the Grand Industrial Exhibition, to be held in London next year. All inventors prefer to have engravings and descriptions of their inventions brought first before the public, through the *Scientific American*. The reason is plain; we have the largest circulation of any other paper, and the public look to our columns for what is new and useful.

### Improvement on Steam Engines.

Messrs. B. Donkin and W. Farey, styling themselves Civil Engineers, have recently taken out a patent in England for improvements in disc engines, connected with which, their patent embraces an improvement in working slide valves to equalize the pressure of the steam on both sides of the slide; to do this, the face on which the valves slide, is serrated or grooved, and these grooves will contain steam under the valve.

### To Inventors and Patentees.

Our list of patent claims is worth more to you than the price of the volume. Our index is so arranged that all the patents granted, are classified, and affords a most useful and standard work of reference. Inventors who consult their own interests, cannot be without the *Scientific American*.

### Crank and Pulley.

A number of experiments with two boats, the one named "Crank," and the other named "Pully," have lately been made on the East River, by Mr. Peter Yates, to test the comparative value of Mr. Yates' invention; the Pully, we have been informed, has universally been the victor. In the course of one or two weeks we will illustrate Mr. Yates' invention of the "Pully," as applied to a steam engine, in place of the crank.

### Notice.

In referring to the address of the proprietors of the Rotary Brick Machine in our last week's number, it should have read, "Address Wagner & Imlay, 203 Market, or 74 Walnut st., care of A. Miller, Esq., Philadelphia."

### India Rubber Flute.

An eight keyed flute made of india rubber has been made in this city, by Mr. Badger. It has a fine polish and looks like tortoise shell. It has a beautiful tone and cannot be affected by the weather.

### Improved Machinery for Grinding Spiral Knives.

Mr. Jas. L. Plimpton, of Westfield, Mass., has invented some valuable improvements on machinery for grinding Spiral Knives, for which he wisely has taken measures to secure a patent. The invention embraces two new and excellent features; one is to grind the edge of every one of the same bevel, and to change the bevel on the frame which holds the knives

without changing the knife or knives, as in the old way; the other is to accommodate the feed of the knives on the frame to the speed of the stone, to make the grinding time uniform—this is done by a friction roller on a swinging frame, running in contact with the stone, so that as the stone decreases in diameter the feed of the knife frame becomes slower in proportion.

### BROWN'S ECCENTRIC TOBACCO PRESS.

Figure 1.

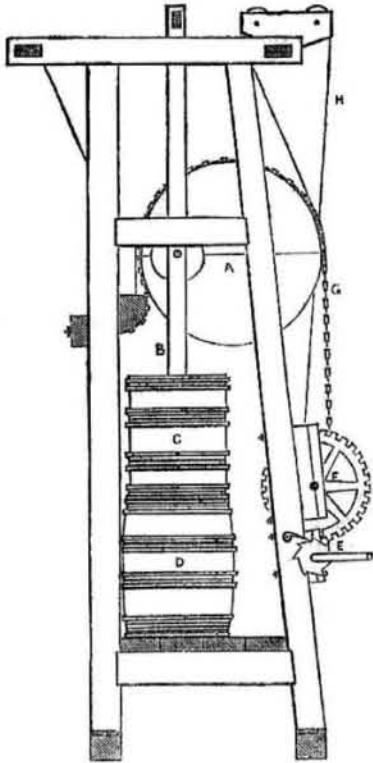
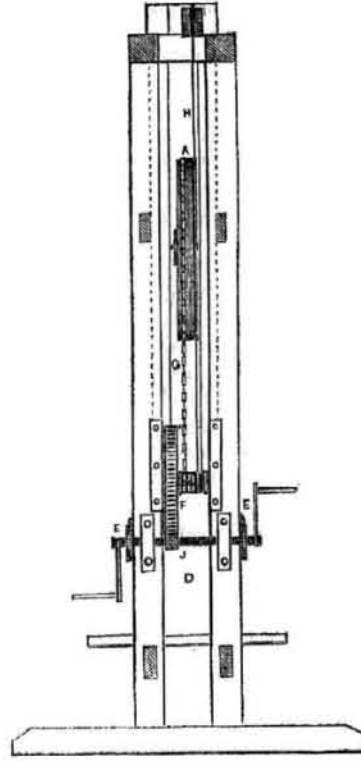

Figure 2.



This engraving represents a side and an end view of a press constructed upon the principle embraced in the patent of Mr. A. D. Brown, of Clinton, in Georgia. It is intended for pressing tobacco on plantations, but it is equally applicable to the pressing of hay, as a cider press, &c. As the principle patented is described on page 96, this vol. Sci. Am., we need not describe it again. In this press the crank, axle and wheel, and the eccentric pulley are combined, and according to modifications of gearing, the power may be increased to any amount; the principle of great speed where little power is required, always being maintained, and *vice versa*. A is the eccentric lever pulley; B is the stock of the pressure block; C and D represent the barrel and packing cover; E E are the ratchets; F, the cog wheel on the drum shaft, which is driven by a pinion, J, (fig. 2); G is the chain passing round the drum, F, over the eccentric pulley, and is secured on a strong block on the frame; H is the rope which raises the follower and block up, after the tobacco, &c., is pressed in the barrel or box. It is not necessary, after our reference

above, to describe the operation, any further than to say, that if the pin is 1-16th of the diameter of the eccentric pulley from its periphery, and a 48 inch cog wheel, 6 inch pinion, 8 inch drum for the chain, and 15 inch cranks are used, the power applied will be multiplied nearly 300 times; any amount of power can be applied by this kind of gearing.

It is, perhaps, a work of supererogation in us to say any thing more in favor of this simple press—to show the beauty and elasticity of application to so many useful purposes, and to set forth its very extraordinary merits. In Georgia, where Mr. Brown has been known for twenty years as a good practical mechanic, his press has at once arisen to eminence, and come into extensive use, and, at the present moment, he has orders from almost every State in the Union for presses, for cotton, hay, tobacco, or some other purpose. All the parts being so simple, so easily made, and so easily kept in repair, no wonder it at once met with a favorable reception when it was first published in our columns.

### Variations of the Compass.

The loss to Great Britain by shipwrecks, appears from carefully prepared statistics, to amount annually to between 500 and 600 ships, or about three vessels in every two days. The cause has been attributed, in a great measure, to misdirections of the compass produced by attractive power of the iron used in the construction of the vessels, as well as the funnels, tanks, and guns employed in men-of-war. The result varies in different cases, and a remedy can only be obtained by direct experiment on board each ship. A "compass observatory" has accordingly been established in England, where every ship of the Royal navy has its compass adjusted before proceeding upon a cruise. The practice has, as yet, not been extended to the mercantile marine.

### The Bakatlas of South Africa.

The Bakatlas work a great deal of iron, manufacturing various articles, with which they supply the neighboring tribes. They obtain their iron from ore, which they procure by excavating in the surrounding mountains. This ore is smelted in crucibles, a great deal of the metal being wasted, and only the best and purest being preserved. They use a sort

of double bellows, consisting of two bags of skin, by which the air is forced through the long tapering tubes of the two horns of the oryx. The person using the bellows squats between the two bags, which he raises and depresses alternately, working one with each hand. Their hammer and anvil consist of two stones. They nevertheless contrive to turn very neat workmanship out of their hands, such as spears, battle-axes, assagais, knives, sewing-needles, &c. The men of this tribe also manufacture large wooden bowls, which they cut out of the solid piece, the tool they use for this purpose being a small implement shaped like an adze.

### The Largest Grape-vine in the United States.

Under this head the Natchez Free Trader, of the 10th inst, has the following paragraph: Mr. William Casey, corner of Union and State streets, in the city of Natchez, can boast of a grape vine which is, undoubtedly, the monarch vine of the United States. It rises from the ground in a single trunk of some three inches in diameter, nearly straight, and well proportioned, to the height of about nine feet, when it spreads into branches, and covers

and embowers the trellis work of quite a large garden, besides climbing a tall tree. The weight of the immense clusters of grapes hanging upon it, now about half grown, is estimated at a ton. To stretch out any of the branches in a direct line, they would measure from three to four hundred feet. The description of the grape is not natural to the country, but was brought to Natchez in the old Spanish times. It is called the "Jack Grape," from "Spanish Jack," the nickname of the Spaniard who planted it. Some years ago, Madame Bingaman, now dead, offered Mr. Casey five hundred dollars if he would remove the vine safely to her garden, in the environs of the city; but no sum of money whatever, would induce the owner to part with it. It produces a wine which has the taste of Hock.

### The Electric Telegraph in Europe.

It is well known that various projects have been proposed for a Transatlantic Telegraph; this will be no easy matter, owing to the length of wires required. In the present state of Electric Telegraph science, it is impossible, owing to the distance of such a length of wire between the batteries. Between Calais in France, and Dover in England, the distance being no more than 25 miles, the project of an ocean telegraph is not only feasible, but the construction of one is in actual operation to unite France and England. The Telegraph is to be on Bain's principle, now so well known in America. The telegraph, like steam navigation, will by the means of spreading rapidly the arts and sciences of civilized nations among all lands. The Dublin University Magazine says:

"When the powers of this improved telegraph shall be brought into full operation, and when the mode of intercommunication shall be available by the public in all parts of Europe, great changes in the social and commercial relations of the centres of commerce and population must be witnessed. Hitherto, the use of the telegraph has been limited to the Government. The public has been altogether excluded from it. Such a system, however, cannot be of long duration, and the precursors of a speedy change are already apparent. A project of law has been presented to the Legislative Assembly, by the French Government, to open the telegraph to commerce and the public. Lines of electric telegraph have been constructed, and are already in operation, along the principal lines of railway in France. A commission has been appointed, by the Belgian Government, to report upon the means which ought to be adopted to construct lines of electric telegraph throughout that kingdom. Lines of considerable extent are in operation in the Prussian States, and still more extended systems are in preparation. Measures are in progress for the establishment of lines of electric telegraphs in the territories of Austria, Saxony, Bavaria, Wirtemberg, Baden, and all the lesser states of Germany. The Emperor of Russia has issued orders for the construction of lines of telegraphic wires to connect Petersburg with Moscow, and with the Prussian, Saxon, and Austrian lines of telegraph."

### Sticking, or Court Plaster.

Bruise a sufficient quantity of isinglass, and let it soak in a little warm water for four-and-twenty hours; expose it to heat over the fire till a greater part of the water is dissipated, and supply its place by proof spirits of wine, which will combine with the isinglass. Strain the whole through a piece of open linen, taking care that the consistence of the mixture shall be such that, when cool, it may form a trembling jelly.

Extend the piece of black silk, of which you propose making your plaster, on a wooden frame, and fix it in that position by means of tacks or pack-thread. Then apply the isinglass (after it has been rendered liquid by a gentle heat) to the silk with a brush of fine hair (badger is the best). As soon as this first coating is dried, which will not be long, apply a second; and afterwards, if you wish the article to be very superior, a third. When the whole is dry, cover it with two or three coatings of the balsam of Peru.