

### RAND'S IMPROVED SAW ARBOR.

Our engraving illustrates an improvement in saw arbors, whereby they may be made not only to carry saws, but also a great variety of tongueing and grooving tools.

Fig. 1 shows the arbor with a saw mounted upon it. The neck of the arbor is made as shown, considerably longer than is necessary to receive the saw and loose collar, and upon this extra length of neck, is fitted a loose sleeve, A, filling the space between the nut, B, and the loose collar, and so clamping the saw firmly.

Fig. 2 shows the method of holding grooving tools, etc. To effect this a radial mortise is cut through the neck of the arbor, and the tool, C, being inserted, is held by the set screw,

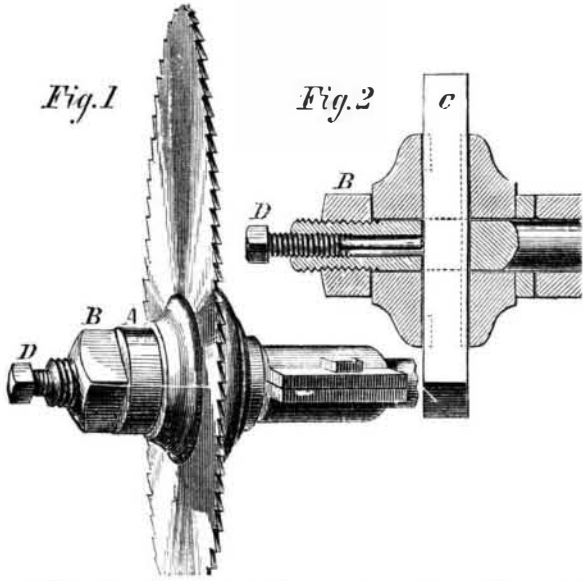

D. Then the loose collar, being placed against it, the nut, B, is firmly turned down, clamping the tool securely.

This is a very simple modification of the arbor, and one which seems practicable and useful. Quite a variety of work could be done by an arrangement of this kind.

The invention was patented through the Scientific American Patent Agency, May 23, 1871, by Jacob Rand, 862 Fourth street, South Boston, Mass., whom address for further particulars.

### IMPROVEMENT IN RIVETING TOOLS.

This is an invention which possesses decided originality, and the principle of which is undoubtedly sound, being analogous to the "spinning" of metals on lathes, and shaping them by friction upon their surfaces. Two equal sized contiguous rollers are hung upon the same pin, and applied against the ends of the pins or bolts under a twofold rotation so as thereby to head the pins or bolts in the desired manner. The contiguous faces of the rollers are notched to give room for the escape of particles that may be rubbed off the pins or bolts.

This invention introduces an entirely new system of riveting by friction, transversely under longitudinal pressure, instead of the ordinary hammering process, which uses force only longitudinally, and racks machinery and buildings, without being continuous in operation. By rotating the tool under lengthwise pressure the action is continuous, and therefore, it is claimed, quicker than hammering, besides being more gentle and less injurious to the machinery. It is further claimed that the fibers of the pin or bolt to be headed will be gradually bent over, and cannot be fractured, as is frequently done by hammering. The rivet produced will consequently be of superior quality to those heretofore made. The machine for riveting the pivots of hinges consists of two of the tools above described, held in line, and a pair of jaws between them, for holding the hinge. The latter is dropped between the jaws and secured, and then the tools are at once applied to both ends of the pivot, rotated till the head is completed, and finally withdrawn. The riveting process can thus, it is asserted, be carried on with great rapidity, exactness, and neatness. Benjamin F. Cobb, of West Troy, N. Y., is the inventor of this novel tool.

### ODIORNE'S IMPROVEMENT IN SEALS FOR HYDRAULIC MAINS OF GAS WORKS.

In the ordinary gas works the gas, in passing from the retorts to the hydraulic main, is intercepted by the hydraulic seal, and has to be forced through by accumulated and otherwise unnecessary pressure in the retort. Mr. Alfred Odiorne, of Springfield, Ill., has invented a new seal, the object of which is to prevent the gas from flowing back to and out of the retorts while the same are opened for drawing and charging. The new seal is therefore only necessary during this brief time, while, by the process in common use, its use is continual. It has always been a desideratum to limit this obstruction to the flow of the gas to the short time needed for drawing and charging; but no contrivance to accomplish this has yet come into use, although much ingenuity has been expended in attempts to that end. This movable seal is intended to produce this desired result.

It consists of a box for each bench placed in the hydraulic main, with a compartment for each dip pipe. When the box rests on the bottom of the main, the top of the box is one inch below the ends of the dip pipes, and when filled with water or the products of condensation it will, consequently, not obstruct the gas, but let it flow freely from the retorts into the main. When the box is raised up, the ends of the dip pipes are immersed, and a seal is thus made, preventing the flow of the gas back to the retorts.

The box is suspended and raised or lowered by means of rods, which pass through the top of the main, and are connected with a weighted lever above it. The holes through which the rods pass are larger than the rods, allowing them to rise and fall with ease, and are sealed from leakage by annular sealing cups. The cups are screwed or otherwise secured to the main, and are of sufficient depth to resist the outward pressure from the main, and are filled or partly filled with water, glycerin, or any other suitable liquid.

To the long and weighted arm of the lever is attached a small chain by which the stoker can easily raise and lower the box.

By this improvement, it is claimed, the back pressure on the retorts is lessened from two to four inches, as the case may be, or about one half of the ordinary pressure, while, in a great measure, the collection of carbon in the retorts will be prevented, as well as the clogging in the stand pipes and leakage, while the yield of gas is increased, labor and fuel saved, and wear and tear lessened. It also obviates the necessity of keeping any liquid in the hydraulic main, giving increased main capacity.

### IMPROVED SELF-MEASURING FAUCET.

Many attempts have been made to introduce the general use of measuring faucets. These instruments have, however, so often lacked the essential elements of simplicity, cheapness, and durability, that few have achieved even partial success.

The one illustrated herewith is certainly very cheap, all the parts being made of plate tin or other suitable thin sheet metal, except the faucet proper, which is of brass, or composition, exceeding in weight and the cost of construction very little that of ordinary brass faucets, of the same capacity.

The working of this device is claimed to be in all respects satisfactory and will be easily understood by reference to the engraving, in connection with the following description.

A is a hollow screw tap and pipe by which communication is established between the interior of the barrel and the faucet proper, C, and through the latter to the interior of the tin plate chamber, E, when the handle of the faucet plug is turned to the right position, beyond which it is prevented from turning by a stop.

From the chamber, E, rises a vent pipe of very small bore, which is inclosed in a protecting pipe, D. It is obvious that when the plug is turned to the right position, the fluid will run out of the barrel through the tap and pipe, A, enter the chamber, E, and filling it, expel the air contained in it through the vent pipe. When thus filled the chamber holds one quart.

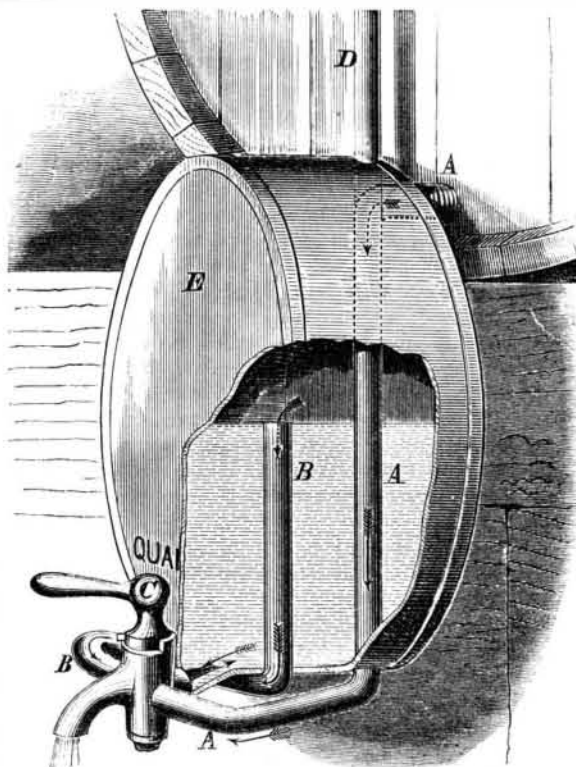

The plug of the faucet is of the kind known as "three-way," its ports being so formed that when the handle is turned to the extreme right, the flow will be from the barrel into the chamber. When turned to the middle position, as shown in the engraving, the flow from the barrel will be stopped, and the fluid in the chamber, E, will flow through the pipe, B, the top of which is so adjusted as to deliver only one half of the contents of the chamber, one pint. When the handle is turned against a stop at the extreme left, the flow passes directly back through the faucet, C, and discharges the entire contents of the chamber, E, the faucet being so placed as to draw off from the lowest point of the chamber. The handle being then turned back to its original position the chamber again fills, and so on, pints or quarts being drawn as desired. This can be done as well in the dark as the light, and hence danger from fire, in bringing lights near casks containing inflammable oils, is avoided. The liquid is drawn directly into the vessel destined to receive it, without the intervention of portable measures, and the uncleanly dripping attending their use. The instrument is well adapted to measuring all fluids; and to the retail trade in coal oils, or for any other fluid which is uncleanly to handle, or likely to be ignited by the approach of an artificial light, it is especially adapted.

The instrument may be made to measure and discharge any two given quantities, but as most burning fluids are re-

tailed in quarts and pints, the instrument will probably meet the most general favor when constructed as described, since any quantity above its capacity can be measured by repeating the measuring and discharging.

Patented through the Scientific American Patent Agency, March 28, 1871, by Dr. William M. Wright, of Chambersburg, Pa., assignor to Phœbus and Wright, whom address for territorial rights or for further information, Fortress Monroe, Va.

### PHILIPPI'S IMPROVED DRILL CHUCK.

The annexed engraving illustrates an improved drill chuck, which will be found a great convenience in many kinds of

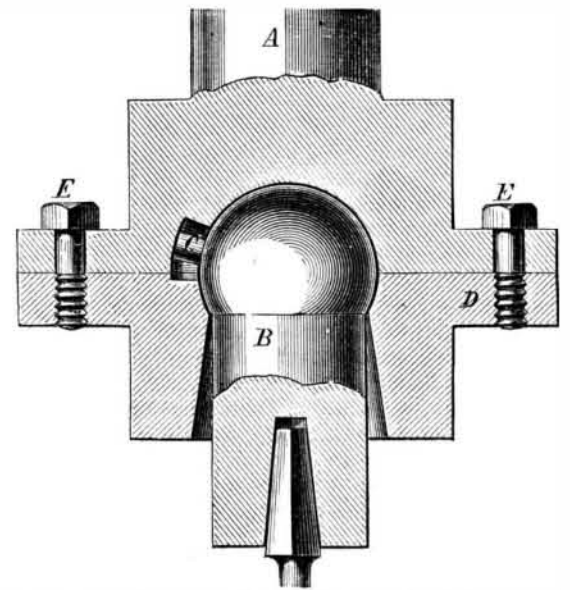

work. It requires no adjustment to center, being so constructed that the point of the drill may be placed upon the point desired to be drilled, where it will remain.

A, in the engraving, is the mandrel shaft, with a globular cavity to receive the drill chuck, B. This chuck is not rigidly confined like ordinary drill chucks, but is allowed to move in any direction, so that the point of the drill will find its center and run true. D is a flange plate or cap, by means of which the chuck is secured to the end of the mandrel, being held by screws, E. The portion of the flange which surrounds the socket portion of the chuck is made flaring to give the chuck play. C is a pin or lug, on one side of the ball, which is placed in a recess formed in the mandrel and cap, by which the chuck is made to revolve with the mandrel.

Patent recently allowed through the Scientific American Patent Agency, to P. Philippi, Beardstown, Ill., whom address for rights or further information.

### Shad and Ferry Boats.

After the establishment of the railroad ferry at Havre de Grace, Md., some thirty years ago, the number of shad, which had been very plentiful in the Susquehanna river, began to diminish, and it was believed that the splashing of the boat had the effect of driving the fish back into the bay to seek other and quieter spawning grounds. About four years ago, a bridge was built and the boat withdrawn, and from that time the number of shad coming in has steadily increased. This year, the yield at Columbia alone has been as high as 3,000 to 4,000 in twenty-four consecutive hours.

[We find the above item in one of our exchanges. We doubt its correctness. The Havre de Grace ferry boats used to run across the river, on an average, about once an hour. The presence of steamboats in other rivers does not, we believe, affect the shad. On the Hudson river, at New York, scores of ferry boats, and steamers of all sizes, are plying night and day. The shad have diminished, but the fishermen attribute the lack to the setting of gill nets, not to steamboats.—ED.]

### Cheap Concrete Flooring.

Among the many modes of using gas tar in making asphalted pavements and flooring with which our correspondents have lately favored us, the following is a good and practicable one: Mix three bushels of coal ashes from a blacksmith's shop with two bushels of gas lime, and then add sufficient gas tar to make a stiff mortar. If the ammoniacal liquor has been separated from the tar, its place must be supplied by adding water till the tar is thin enough for use. For stables and cattle sheds, the mortar can be laid down with a spade, and fine sharp sand or gravel sifted over it; then roll well, and you will have a good concrete floor. It will take a few days to get thoroughly hard, even in dry weather; but it will be a good piece of work, if carefully done. Autumn is the best time for laying this kind of pavement.

### Competition among the Perpetual Motion Seekers.

Mr. E. Connellan, of Water Street, New York city, writes us that he will furnish at three days' notice, a perpetual motion or gravitating machine, upon a guarantee that he shall receive a certain sum of money to be named by him to the individual who jumps at the chance. We regret that the announcement of Mr. Connellan's invention has been anticipated by James A. Hamilton, of Maine, a description of whose machine appears in another column. However, he may console himself by reflecting that Mr. Hamilton has also been anticipated by Mr. Paine, of Newark, who, producing 67,000,000 foot pounds by the consumption of three grains of zinc, is likely to beat all other perpetual motion men out of the field.