

REFFELT'S CALCULATING MACHINE.

Many attempts have been made to devise a simple and cheap calculating machine. For the most part these attempts have been confined, in the cheaper class of machines, to performing only the one operation of addition. The machine, engravings of which accompany this article, is capable of performing the four fundamental operations of arithmetic—addition, subtraction, multiplication, and division being executed with equal facility and accuracy.

The engravings give views of opposite sides of the machine, the converse operations of addition and subtraction being performed on the side shown in Fig. 1, and multiplication and division on the side shown in Fig. 2.

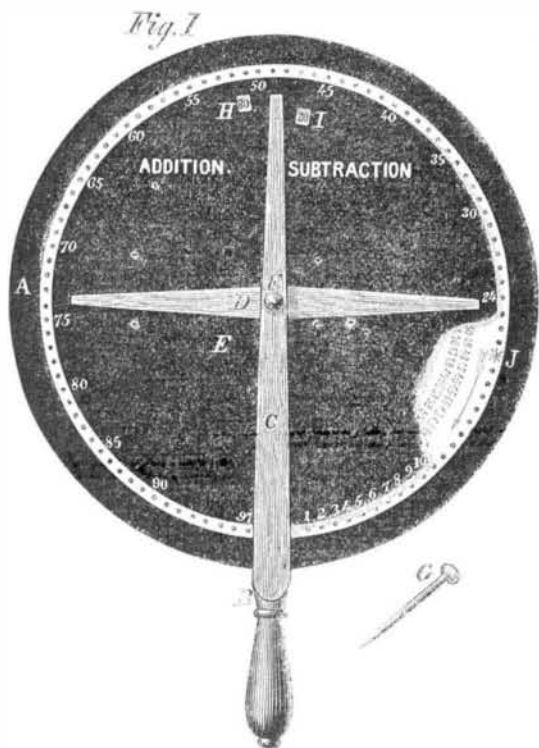

An external rim or hoop, A, is fastened to a bifurcated handle at B, the bifurcations, C, extending up on each side of the frame, and forming, with the pieces, D, crosses, to which the stationary disks, E, are fixed. Beneath these stationary disks is a revolving disk which turns on a central pivot, F, when actuated by the style, G, Fig. 1, the latter being held in one hand of the operator, while the handle, B, is grasped in the other hand, and the style, G, being inserted in one or other of the small holes drilled in the outer edge of the revolving disk, as hereinafter explained.

The fixed disks, E, are smaller than the external hoop, A, or frame, and, also, smaller than the revolving disk, the edge of the latter fitting in a groove cut on the inside of the hoop, A. Thus, an annular space is left between the hoop and the disks, E, through which the outer part of the revolving disk is seen. On the outer part of the latter, next to the hoop, are shown the holes which receive the point of the style, G, when the machine is in use. There are one hundred of these holes.

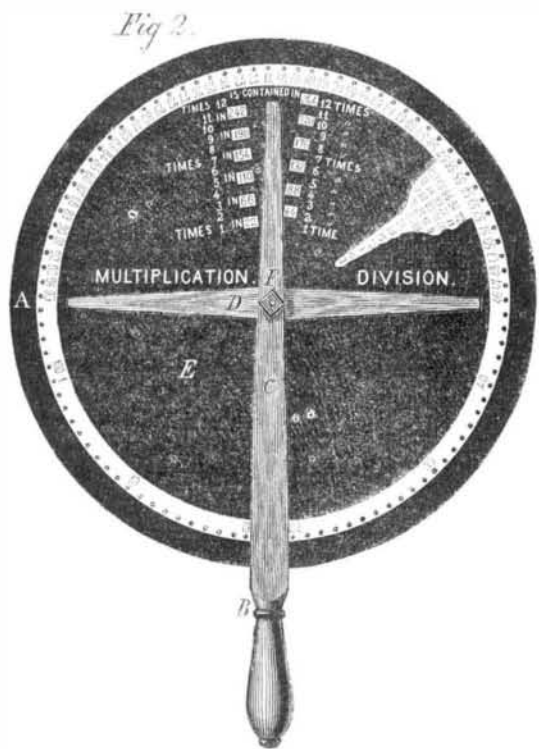

On the addition and subtraction side, the fixed disk, E, has marked on its outer edge numbers from 1 to 100 inclusive, placed at equal distances from each other, only the first ten of these being shown in our engraving, drawn in full, the rest being indicated in fives on account of limited space.

Upon this side of the revolving disk are two concentric rows of numbers, progressing in opposite directions from one to one hundred inclusive, portions of which are shown where a portion of E is broken away. As the revolving disk is turned by the style, the numbers in the outer row appear successively at the aperture, H, in the disk, E, and those in the inner row at the aperture, I.

Suppose, now, it is desired to add 6 to 7. One of the holes, J, to which the style is applied, is conspicuously marked. The style being placed in this hole, the revolving disk is turned in the direction of the arrow until the style is brought flush with C, when 0 appears at each of the apertures, H and I. The style being now placed in the hole at 6, the movable disk is rotated until the style stops at C, which brings the number, 6, to view at the aperture, H. The style is then withdrawn, and again inserted in the hole next to 7, and carried back to C, which brings 13, the sum of six and seven, to view at H. Two columns of figures can be operated upon at once, as it is just as easy, by this machine, to add 36 to 47, as to add 6 to 7, and by making a mark or tally every time a hundred is passed, the addition may be carried to any extent, thus: 70, 81, 96, 48, would be added in the following manner, J being first brought to C. Carry the style from C to 70, and bring that number to C; do the same with 81, and make a tally mark for the hundred passed; 51 now appears at H. Next carry 96 round to C, and tally for the second hundred passed; 47 now appears at H. Next carry 48 round to C; 95 now appears at H, which, with the two hundreds tallied, make the sum 295. A very little practice will enable the operator to carry the hundreds in the mind without recording them. In this way, two columns, of any length, may be added simultaneously. The sum of each successive two columns being set one place below the preceding sum, and two places to the left, and the several sums added, enable the machine to be applied to adding any number of columns.

Subtraction can be, of course, performed in a converse manner, but it is more convenient to reverse the order of succession in a second row of figures, hence such a row of figures is added, which successively appear at the aperture, H. Suppose it is required to subtract 29 from 36, the instrument being set to zero. The style is placed in the hole opposite 36 in the fixed disk, E, and brought back to C; this brings 36 to view at the aperture, I. Next the style is placed in the hole corresponding to 29, and again brought to C, when the required difference, 7, appears at the aperture, I.

On the multiplication and division side, Fig. 2. The movable disk has upon it concentric rows of numbers, portions of which are shown by the breaking away of a part of the fixed disk, E. The inner row contains the numbers from 1 to 100; the next, the numbers from 2 to 200, which are divisible by 2; the next, those from 3 to 300, divisible by 3; and so on to the outer concentric row, which contains the numbers from 12 to 1,200, divisible by 12. As the revolving disk is rotated by the style in the same direction as in adding or subtracting, the numbers in these rows are successively brought under the apertures placed at the right and left of C, at the upper part of the fixed disk, E. The annular space between the hoop and the fixed disk, E, has upon it a row of figures from 1 to 100, inclusive, progressing in a contrary direction to the numbers on a clock dial. These numbers are so arranged, that when any one of them is brought by the rotation of the revolving disk flush with the bar, C, the products obtained by its multiplication into the odd numbers from 1 to 11, inclusive, appear at the left hand series of apertures, and the products obtained by its multiplication into the even numbers from 2 to 12, inclusive, appear at the right-hand series of apertures, the smallest product in each series being the inner one, and each series of products increasing regularly outward.

It is evident, therefore, that the multiplication of any number from 1 to 100, inclusive, by any number from 1 to 12, inclusive, is performed by bringing the multiplicand flush with C, by the use of the style, when the required product will appear in the aperture adjacent to the multiplier. Conversely, the quotient of any number from 1 to 1,200, inclusive, exactly divisible by any number from 1 to 12, inclusive, is found by bringing the divisor flush with C, when its quotient will appear opposite the dividend, which latter will show itself at one or the other of the apertures.

For the multiplication of the larger numbers, the amounts are divided. For example, suppose 123 to be multiplied by 5,689, the latter number is first multiplied by 12, and again by 3; and the latter product being set beneath the former, and one place to the right, the products are added, the sum being the true product.

Besides being adapted to business purposes, this machine is applicable to use in schools, for purposes of instruction. Further illustration of its operation is not needful, as the means of extending its use to many arithmetical operations will suggest themselves to arithmeticians.

Patented through the Scientific American Patent Agency, Sept. 14, 1869, by J. H. R. Reffelt.

For instruments, or rights to manufacture, address E. Steiger, publisher and dealer in German books, 22 and 24 Frankfort street, New York.

To Correspondents.

We have on hand a mass of interesting and valuable correspondence, and there must necessarily be some delay in its appearance; but it shall be attended to as fast as space will permit, and we shall be glad to get more of the same sort. If you have got anything practical you wish to bring forward send it along, and don't be too diffident about sending it in homely dress. We will take care that it does not put to blush the orthography and grammar of those unskillful in writing for publication.

WE invite the attention of our readers to the announcement for the forthcoming Volume, 1870, on another page. It will be seen that premiums are to be given to all who send lists of subscribers of twenty names and upward.

IMPROVED UNIVERSAL HANGER FOR SHAFTING.

The form of hanger known as the universal hanger for shafting, from its utility in leveling and lining shafting, and the reduction of friction accomplished by its use, has grown into general favor. Our engraving illustrates still another improvement upon this form of hanger.

The engraving will show that the same general principles of construction as have hitherto been employed, are retained, viz., bearings having their axes placed at right angles; but the vertical screws engage with the upper and lower halves of the box, which is divided as shown.

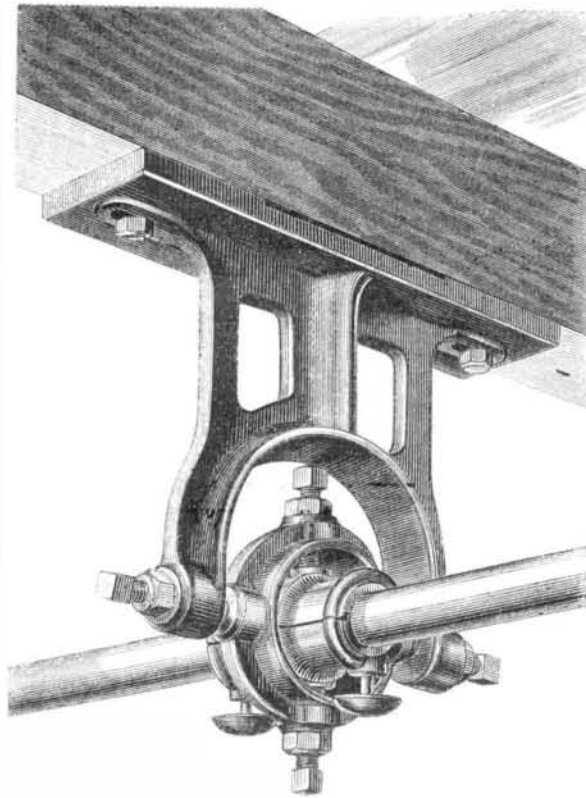

This arrangement enables the box to be made in halves and held together without the use of special bolts for this purpose, the upper and lower bolts in this hanger performing a double office.

The convenience of this arrangement is manifest, and besides the additional convenience, the fact that the wear of boxes may be taken up by the vertical screws, is another consideration in favor of this form of hanger.

An application for a patent on this improvement is now pending through the Scientific American Patent Agency, by J. Gallatin, Jr., of New York, and the hangers are manufactured by the Gallatin and Brevoort Machine Works, 223 Front street, New York.

USEFUL BLOWPIPE.

We give herewith engravings of two useful blowpipes, copied from the *English Mechanic*. The first illustration, Fig.

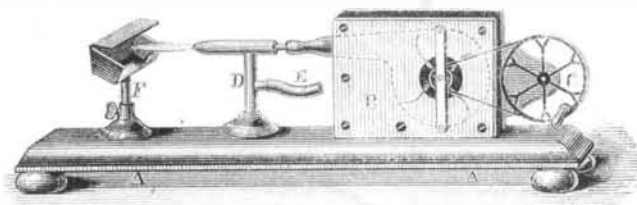

1, consists of a wood stand, A, a fan with sheet-iron frame and wood sides, B, a small driving wheel, C, and a blowpipe, D, with foot and blast tube running through its center connected by a flexible tube to the fan. E is the tube which conveys the gas to the flame, the gas escaping from an annular opening around the nozzle of the blast tube. F is a sheet-iron support for charcoal on which the article to be brazed is placed.

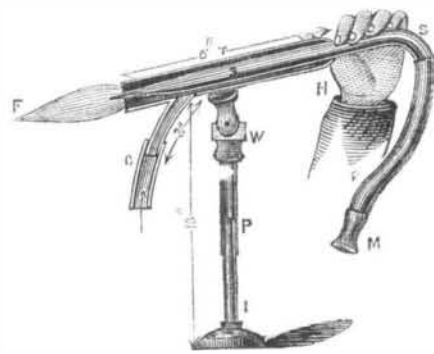

Fig. 2 is a blowpipe for light work which a contributor to the paper alluded to above, says he has used, satisfactorily, for six years. F is the flame, G is a gas tube, M the mouth piece, H the hand of the operator to draw the slide, S S, out a little for a large flame, and to compress it for a small one, T is the outside tube, into which tube, S S, slides; I is the iron wire stand; W is a gas swivel, and P the gas pipe to swivel on the stand adjustable on I.