

TURNER'S ROTARY STEAM ENGINE.

Judging from the statements of the inventor and patentee of the engine illustrated in the accompanying engravings and an examination of his claims and model, it would seem that he has succeeded in improving upon other rotaries, in diminishing friction and using his steam to the greatest advantage and with the least possible waste. He is the publisher of the Grand Rapids (Mich.,) *Daily Eagle*, and he says: "We are running one of these engines in our press room and it works admirably. This engine is twelve inches diameter and eight inches between heads; it has a steam opening one and a half inches wide, and drives, with sixty revolutions, two Hoe cylinder presses and a Gordon Franklin with ease."

The engine with one head removed is seen in perspective in Fig. 1. It has a light balance wheel attached, which, however, it is not believed is absolutely necessary, as a regular and even rotation is kept up without it. The figures 2 and 3 present transverse and longitudinal sections of the machine. In the description the same letters refer to similar parts.

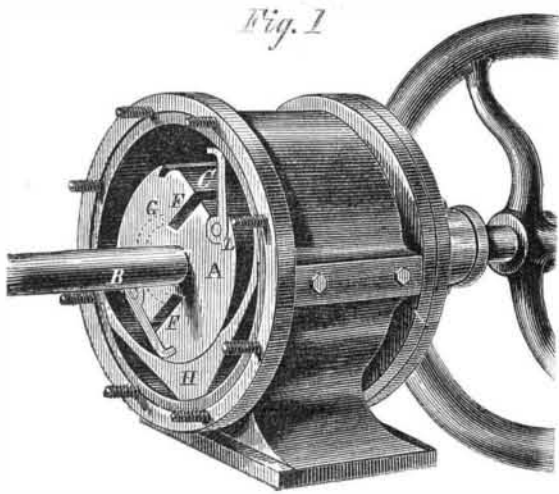

Inside the cylinder is a cylindrical piston, A, secured to the shaft, B, its ends fitting closely the inside of the cylinder heads. In the periphery of this revolving piston are hinged or pivoted wing valves or arms, C, which when closed form a portion of the periphery of the piston, and when opened impinge against the inner surface of the cylinder. Steam is admitted at the point, D, Fig. 3, to a chamber in one of the heads, shown by the parallel curved dotted lines in Figs. 1 and 2 and the opening, E, in Fig. 3. This steam chamber, being always filled with steam, supplies the annular space between the outside of the revolving piston and the inside of

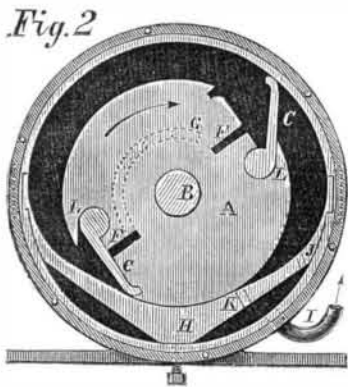

the cylinder, and passes under the wing valves through the passages, F, in the piston, which extend across its length. The steam thus admitted acts on the valves and is cut off at G, which cut-off may be increased to any desired extent by filling a portion of the steam chamber in the head between G and the induction pipe.

The double cam block, H, to save weight and material, is made hollow, leaving spaces between it and the inside of the cylinder. From one of these spaces the exhaust pipe, I, carries off the steam which is received from the steam space at

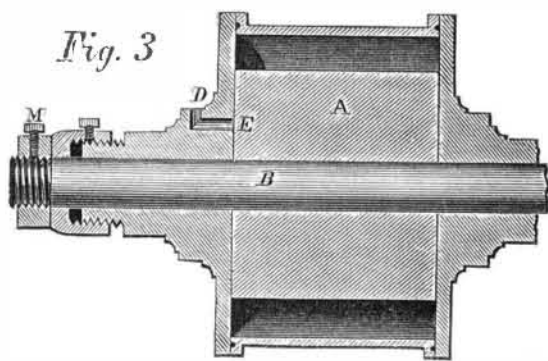

two points (Fig. 2), J and K, the first being a small opening to relieve the pressure upon the valve in closing, thus preventing any clicking noise and any unnecessary wear of the valve; the exhaust through the main opening, K, not taking place until the valve is entirely shut to place. As the acting steam passes under and acts upon the valve at the precise point at which it begins to open, it keeps out the point of the valve so as to follow the elliptical surface of the cam until it finds its proper bearing on the shoulder, L, at the same time the point of the valve forming a steam tight joint on the inside of the cylinder. As the steam has not exhausted in front of the valve until it finds its proper bearing, very little friction is produced by the opening of the valve. The direction of mo-

tion of the engine is shown by the arrow in Fig. 2. In Fig. 3 is seen a collar, M, screwed on the end of the shaft to prevent the pressure of the steam, which is admitted at that end, from forcing the piston against the opposite end of the cylinder. This collar forms a joint with the stuffing box.

From the foregoing, together with the examination of the engravings, the engineer or mechanic will readily understand the operation of the engine. Further information may be obtained by addressing Turner & Company, Publishers *Daily Eagle*, Grand Rapids, Mich.

ORNAMENTAL PETROLEUM STOVE.

Though we have freely expressed our disapproval of chimneyless stoves in general, we must admit that the essential defect of such heat generators is almost inappreciable in the portable petroleum stoves which Messrs. James Hinks and Son are now manufacturing under letters patent. Wherever an ordinary petroleum lamp can be kept burning without inconvenience, one of these stoves may be safely used, for the source of heat is simply a petroleum flame from a flat one-inch burner. As the fuel is hydrocarbon, free from sulphur, no offensive and corrosive sulphur compounds are produced by its combustion. Moreover, the bright, white heat of the flame insures the full oxidation of the carbon, and prevents the formation of that lower poisonous oxide which is produced by the slow combustion of coke and charcoal. According to theory, therefore, petroleum is better adapted as a fuel for portable stoves than either coal gas or solid carbon, and we do not fear a conflict between experience and theory. Our own experience, as far as it goes, justifies us in recommending this new petroleum stove as an effective and inoffensive source of heat in halls, shops, warehouses, conservatories, ships' cabins, etc. For warming small conservatories they are admirably adapted, as the flame of petroleum produces what is called a "moist heat"; in other words, a large amount of aqueous vapor results from the combustion of the hydrogen contained in the hydrocarbon. The annexed engraving represents a stove in which the portion surrounding the flame is formed of ground glass, in order that the stove may be at once a source of light and heat. The base of the stove is the reservoir for the petroleum, and is capable of holding three

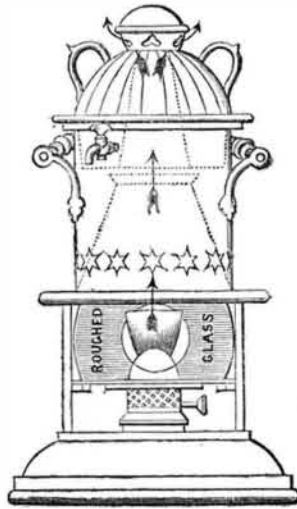

pints, or sufficient for a week's average consumption. Upon this is fitted a flat one-inch burner, above which rises a cone of metal, communicating with a conical chimney. The draft produced by this arrangement obviates the necessity of employing a glass chimney, which would, of course, intercept a considerable amount of heat. The outer case of the stove, which is made of planished copper, is provided with handles, by which it may be lifted, and a small oval window, through which the flame may be seen. On the top of the outer case is fitted an ornamental hot-water reservoir, or boiler, capable of holding three pints, and provided with a draw-off tap. The heat, passing through the centre of this reservoir, maintains the water at the boiling temperature, and the steam escapes with the heated air, by openings in the spherical ornament covering the chimney. The height of the stove is twenty inches; its diameter six and a half inches.—*Ironmonger.*

Formation of Dendrites.

Dr. Emerson Reynolds read a paper before the Royal Geological Society of Ireland on the formation of dendrites. He had some years since noticed that, when solutions of salts were placed upon a plate of clean glass, and the glass placed between the poles of a Ruhmkorff coil, the salts gradually worked over the surface of the glass in beautiful moss-like forms, which in many cases were characteristic of the compound contained in solution; the state of dilution at the same time, having some considerable influence. The author proposed to call these "electric cohesion figures." To produce them we will say that a drop of a solution of cyanide of potassium is put in the center of a plate of glass, which is then placed upon a sheet of tin foil. One pole of the coil (it is immaterial which) is then brought into contact with the foil and the other pole is placed in the center of the drop; immediately on passing the current the solution begins to creep over the surface of the glass in moss-like convolutions.

The dendritic markings on minerals the author believed were formed under a similar condition. He exhibited a beautiful manganese dendrite taken out of the museum. It was a conchoidal limestone slab, and in Dr. Reynold's opinion illustrated his electrical explanation conclusively. There was originally a flaw in the limestone which was exactly at right angles with the plain of cleavage. Through these flaws, as was evident by the marks, the manganese solution had percolated, and had perhaps ultimately been the means of making the stone part in two, not however in the direction of the flaws, but in the plain of cleavage. The dendrites which were formed upon the surface in this case were produced from the well-known fact that two surfaces at the instant of their separation are in opposite electrical conditions.

This phenomenon may be illustrated to a certain extent by

inserting a drop of the fluid into the interstice of a plate of mica, and then on suddenly parting the plate the dendritic forms are shown. To fix them the author dusts some finely dried pigment over the surface of the still moist plate, and then fixes this by some transparent varnish.

Ascendency of Machinery over the Power of Sinew and Muscle.

Our age is characterized by the grandest development of mechanical power ever known in the history of the human race. The machine power of England and Wales is competent to perform the labor of nearly six hundred millions of men; and is probably greater in productive capacity than the labor power of all the world besides. The machine power of the United States, through growing with amazing rapidity, does not more than equal the labor power of two hundred millions of men. It is owned, of course, almost exclusively by the North.

This mechanical power, wherever developed and wherever possessed, is placing the communities employing it far in advance of others in wealth, population, and political and financial power. This form of industrial energy began to take growth in England about one century ago, when that country was yet almost exclusively agricultural; when it exported largely of grain, and imported largely of manufactures; when its industrial interests were all in a languishing condition; and when, consequently, it was too feeble to suppress a "rebellion" represented by fifteen or twenty thousand soldiers under the command of George Washington. Abundant statistics are available to show that the agricultural communities of England have advanced since that time very slowly and inconsiderably, except so far as they have been stimulated by the presence of manufactures; and that the wonderful development of the island in the intervening period has occurred exclusively in its mining and manufacturing population. So vast is the present capacity of Great Britain for protection and for the execution of labor, that it can underbid the whole world in the sale of merchandize; and even the enterprising and boastful Northern States of America, notwithstanding the aid derived from the highest tariff ever enforced, are about to experience a financial collapse, in consequence of an excess of imports over exports in their foreign trade; an excess amounting to several hundred millions of dollars per annum. So completely does this tremendous machinery power secure to Great Britain the command of trade and the tribute of the world, that other countries will have to reverse their previously received axioms of political economy, in order to protect their industrial interests from the crushing competition of so colossal a power.—*Hunt's Merchants' Magazine.*

THE "OSCILLATING OR VARIABLE ECCENTRIC MOTION."

This invention is designed to further develop the great mechanical lever called the eccentric, and adapt it to a greater field of usefulness by attaching oscillation to it, thus making it, as it were, flexible, still rigid, but at the same time allowing the eccentric rod to oscillate, swing, or vary from the eccentric, in its true line of motion.

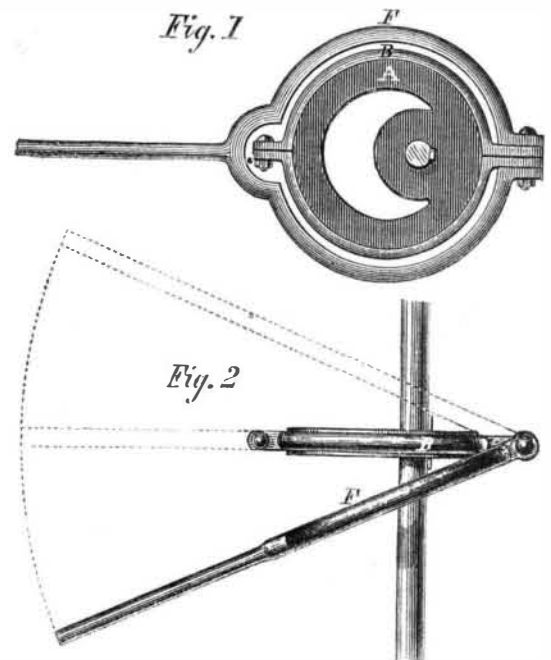

By reference to the accompanying engravings, Figs. 1 and 2, it will be seen that by the attachment of the exterior band, F, in the manner shown, the eccentric rod has perfect freedom to swing, while the eccentric block, A, is keyed firmly to the shaft, and revolves in its true line of motion. Also, by this arrangement, the eccentric rod may be set, if required, at almost any angle to the line of eccentric motion, and still work freely. By this means, marble, wood, etc., may be sawed or cut, of a tapering or angular form, without changing or moving the body being cut; or angular or irregular grooves in iron, etc., may be cut or planed with facility. Also, by this arrangement, two or more eccentric rods, B, may be attached to the same eccentric, for driving two or more pumps, or independent lathes, etc. In fact, this invention is applicable to a great variety of purposes and uses, too numerous to mention.

The device herewith illustrated was patented through the Scientific American Agency, by Timothy Keeler and Geo. S. Avery, of Danbury, Conn., April 28, 1868. All communications regarding it should be addressed to Keeler & Avery, Danbury, Conn.