

Science and Art.

Notes on the Progress of the Paddle and Screw.—No. 4.

The contrivances for feathering floats are numerous. In some cases, each float turns like an oar on a spindle, radial from the shaft, as in Duquet's plan, in 1693, where they feathered by fixed tappets. This was frequently patented afterwards. Two sets of such floats were used by Oldham (1820); Stead (1828) turned them by grooved guides, and Symington (1834) by cog wheels. But the more common method was to cause the float to feather on a horizontal axis, parallel with the shaft. Silvester (1792) effected this by a spindle turned by a fixed cog wheel; Broomfield (1825) made the principal cog wheel adjustable by a screw; Steenstrup (1827) and Brown (1845) used an endless chain to regulate the angles of the float; Holebrook (1832) used a spindle, with a worm at one end and a pinion at the other. Curved rims, or cam guides, feathered the floats by acting directly on catches, in the plans of Binns (1822), Pool (1829), and Winkles (1840). Parr (1825) caused the pressure of the water to feather the float on an axis dividing it unequally; Binns (1822) loaded the float so as to keep one edge always lowermost. This mode was repeatedly patented. Lambert (1819), Mercy (1825), tried to make the float feather by buoyancy, and Hill (1825) connected all the floats together by forked jointed pieces. Skene (1827) combined these two last means, and bridle bars were added by Vint (1835). Long before this, Lambert, in 1819, kept the free edges of the floats lowermost, by attaching them all to a heavy circular rim without central bearings. Cochran patented this ten years afterwards, and Napier did the same in 1841. Miller (1848) had small guide rollers to steady the rim and increase the vertical pressure. Parlour (1838) feathered the floats by a divided shaft, of which the part attached to the float spindles turned twice for each revolution of the other part.

In 1813, Robertson Buchanan patented his invention for feathering each float by a spoke from an arm on its spindle, jointed to a rim turning on a fixed eccentric.

This application of the eccentric was repeatedly patented, in various shapes, and many of the plans are so similar, if not identical, that it is evident their inventors were ignorant of what had been done before. It is to be regretted that, in many of these cases, from £300 to £500, besides often ingenuity, time, energy, and private expenditure, were thus needlessly thrown away; and it is to be hoped that, by the enlightened policy of the present authorities at the British Patent Office, invention will be delivered from a useless repetition of past efforts, and genius will be set free to cultivate new fields of labor.

In 1827, Oldham put the feathering eccentric on a hollow shaft, embracing the paddle shaft, and so turned slowly, by fixed cog wheels, as to cause the side edges of each float to point to the top of the wheel.

Bernhard (1828), Anderson (1828), and Gifford (1837), made the eccentric adjustable, so as to regulate the angles of exit and entrance of the floats. This is done by levers, or by a sector working a frame-work jointed to the rods that work the floats.

In Lagergren's plan (1855), the rim on one side was higher than that on the other, and each float revolved on horizontal bearings, placed at its diagonal points.

Pickworth (1836) made each feathering float to consist of a frame carrying louver boards on vertical spindles.

In Bramwell's plan (1851), an eccentric motion and springs caused the arm and float to yield at the beginning of the stroke, and to work at greater angular velocity near the end. Ross (1856) gave to the outside edge of

hinged floats a similar variable motion. The paddle floats of the *Leviathan* do not feather.

Among the few patents relating to paddle boxes, we may notice Cochrane's (1818), for forcing smoke from the furnace into a closed paddle box partly submerged, so as to exclude the water. Palmer (1839) did this by pumping in air, while Taylor (1846) allowed it to be forced in by the waves. Symington (1835)

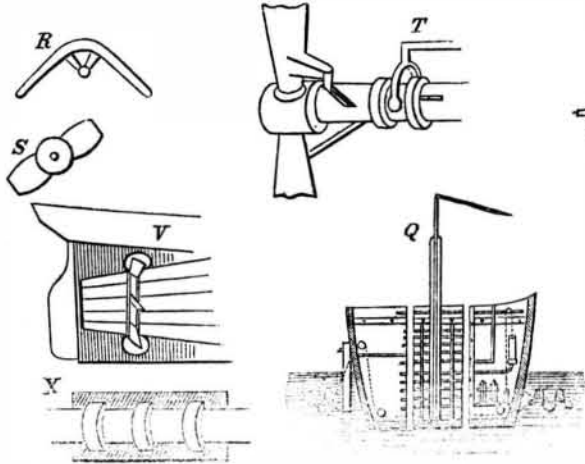
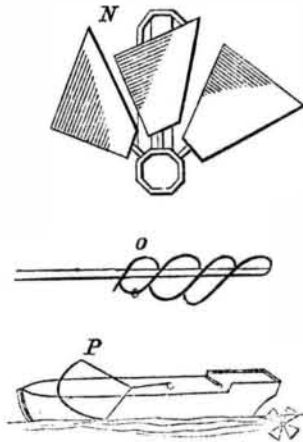

of the stream turned its shaft so as to wind up a rope.

In 1746, Bouguer states that "revolving vanes, like those of a windmill," had been tried for the propulsion of vessels, but it is not clear that the axis was turned by force inside the vessel, or that the method was an advance on that of Duquet.

This week we present some more illustrations of the different forms of propellers which have been, and are still, used.

N. Duquet's oblique vanes (1729), turned by the stream, and winding a rope attached to a vessel. O. Watt's suggested screw propeller (1770). P. Screw tried by Fulton (1798). Q. Dallery's patent screw steamer (1803, France). R. "Bommereng propeller," turning on its center of gravity. S. Griffith's screw propeller (1849). T. Woodcroft's vary pitch apparatus (1844). U. Duncan's (1856) double conical hollow float, turning on its axis, and propelling by a spiral rib. V. Burch's propeller of inclined vanes on a revolving plate (1852). W. Tombs' propeller, with one screw behind and above the other geared to it. X. Ordinary grooved bearing block, used to receive the horizontal thrust of the propeller shaft in the *Leviathan*.

Artificial Ivory.

Charles Westendarp, Jr., of London, has invented a new composition, which can be made to imitate ivory, bone, horn, coral, or other similar substances, natural or artificial, and which may be used in preference to ivory and other such like substances, by being molded or turned to the various forms or patterns they may be desired to take.

The patentee takes any certain quantity of small particles of ivory, bone, wood, glass, cotton, wool, or other similar articles, either in a coarse or fine powder, or in shavings, according to the imitation which is intended, and combines them, or any of them, according to the purpose required, with gums or other resinous materials, such as gum damar, gum copal, resin, gum shellac, gum sahdrac, wax, or other glutinous or resinous materials. These ingredients he combines by pressure or heat, or with spirit, or other solvent, and forms a mixture of the whole, or any of them, which may be colored during the process. A paste is thus obtained, which may be immediately molded, and becomes solidified in a short space of time by means of heat or pressure, or it may be so manufactured as to remain in a pasty condition for a considerable time, in order to allow it to be carried to any distance, or worked into any form; for instance, such as decorating in buildings, for moldings, scrolls, or similar ornamental work; the hardening materials being added as required.

The application of the material called "ar-

led the spray from the paddle box to cool the engine; and the well-known paddle box boats were patented by Smith in 1838.

We must go back again to early times for the first appearance of the screw propeller. It is probable that, as the action of a water-mill suggested the use of the paddle wheel, so the motion of a windmill may have prompted the use of the oblique vanned propeller. The wind-

mill is of an unknown antiquity. There is an interesting description of it by R. Hooke, in 1681. It will be observed that under the term "screw propeller," we include every rotating propeller with oblique vanes which urges the vessel in a direction parallel to the propeller shaft.

In 1729, Duquet submerged an apparatus like a smoke-jack or windmill, and the action

tificial ivory," may be very various besides those already named, as it is capable of being made to resemble sculptured articles, by means of dies or chasing, or it may be turned, carved, sawn, and polished, like ivory, bone, or other similar substances. In illustration of the manufacture of artificial ivory, the patentee explains the method of making white billiard balls. For this purpose he soaks ivory dust, say, five ounces, and a white color, say, white lead or zinc white, three ounces, in a solution of eight ounces of white shellac or copal in sixteen ounces of spirit of wine. After the whole is well mixed—which is best done at a temperature a little below or above the boiling water—the alcohol is partially or wholly evaporated, and the stiff paste or dry powder pressed into a solid mass in a pair of dies or mold, previously heated to about 230° to 280° Fahr.; after being so solidified, the compressed balls are worked round and polished like the ordinary ivory balls. The same purpose is effected by reducing eight ounces of white shellac, three ounces of white color prepared of bismuth, lead, or zinc, with five ounces ivory dust, bone dust, or any other suitable matter to a fine powder, and passing it between heated metal rollers repeatedly, at about 230° to 280° Fahr. By this process, a soft homogeneous mass is obtained, which can easily be molded into any desired shape, and forms, when cold and hard, a very ivory-like material.

The patentee claims the amalgamation of the aforesaid or similar articles, thereby producing artificial ivory, and which is applicable to the purposes hereinbefore mentioned.

Carbonization of Gas.

M. Vesian has recently been renewing, in Paris, an old idea in connection with illuminating gas. From chemical and photometric observations which he has made, he has come to the conclusion that there is a great percentage of the hydrogen which really gives no illumination, in the ordinary coal gas, and that the amount of light given by a definite quantity of gas can be increased materially by adding to it the vapor of any highly carbonaceous fluids. This has all been done before; but M. Vesian has contrived a new apparatus for adding more carbon to the gas; and also suggests the use of the waste products of gas-making, such as tar and oils, as the substances with which to add the solid particles that give illuminating power to the gas.

Consumption of Gold and Silver.

The consumption of gold and silver at the present day for household purposes is enormous, its application having increased rapidly since the discovery of gold in California and Australia. The amount of gold and sil-

ver annually taken from the mines of Europe is valued at twenty-five millions of dollars. In America, the yield is computed to be one hundred and forty-six millions, and Asia produces twenty-five millions. Africa has no silver mines, but produces gold to the amount of nearly three millions of dollars. Australia is also without silver, but produces gold to the large amount of two hundred millions.

NEW VOLTAIC BATTERY.—M. M. Fommier & Alix, of Paris, have made an improvement on the voltaic battery by substituting lead for zinc, and they use only one acid; no amalgam is required and, it gives a steady constant current suitable for electroplating and similar processes.



INVENTORS, MILLWRIGHTS, FARMERS
AND MANUFACTURERS.

FOURTEENTH YEAR

PROSPECTUS OF THE
SCIENTIFIC AMERICAN.

This valuable and widely circulated journal entered upon its FOURTEENTH YEAR on the 11th of September.

It is an Illustrated Periodical, devoted to the promulgation of information relating to the various MECHANICAL and CHEMICAL ARTS, MANUFACTURES, AGRICULTURE, PATENTS, INVENTIONS, ENGINEERING, MILL WORK, and all interests which the light of PRACTICAL SCIENCE is calculated to advance.

All the most valuable patented discoveries are delineated and described in its issues, so that, as respects inventions, it may be justly regarded as an *Illustrated Repertory*, where the inventor may learn what has been done before him in the same field which he is exploring, and where he may publish to the world a knowledge of his own achievements.

Reports of American Patents granted are also published every week, including official copies of all the PATENT CLAIMS. These Patent Claims are furnished from the Patent Office Records expressly for this paper, and published in the SCIENTIFIC AMERICAN in advance of all other publications.

Mechanics, Inventors, Engineers, Chemists, Manufacturers, Agriculturists, and people in every profession of life, will find the SCIENTIFIC AMERICAN to be of great value in their respective callings. Its counsels and suggestions will save them hundreds of dollars annually, besides affording them a continual source of knowledge, the value of which is beyond pecuniary estimate.

TERMS OF SUBSCRIPTION—Two Dollars a Year, or One Dollar for Six Months.

CLUB RATES.
Five Copies, for Six Months.....\$4
Ten Copies, for Six Months.....\$8
Ten Copies, for Twelve Months.....\$15
Fifteen Copies, for Twelve Months.....\$22
Twenty Copies, for Twelve Months.....\$28
Southern, Western and Canadian money or Post Office stamps, taken at par for subscriptions. Canadian subscribers will please to remit twenty-six cents extra on each year's subscription, to Pre-pay postage.
For all clubs of Twenty and over, the yearly subscription is only \$1.40. Names can be sent in at different times and from different Post Offices. Specimen copies will be sent gratis to any part of the country.

MUNN & CO., Publishers and Patent Agents,
No. 128 Fulton street, New York.