

Science and Art.

A New Planet.

The forty-fourth of the minor planets was discovered by M. Goldschmidt, at Paris, on the 27th of May. The planet resembles a star of the 10.11th magnitude. A new star has been discovered in the nebula of Orion, by M. Porro, at Paris. It was first seen by him when trying an object-glass of 20.5 inches in diameter, the eye-piece magnifying 1200. He has again seen it twice, and his observations have been since confirmed.

Steam Fire Engines.

We notice from the proceedings of the City Council of Chicago, as reported in the *Press*, that after a careful examination into the relative merits of the various steam fire engines, an order has been given to Silsby, Mynderse & Co., of Seneca Falls, for one of Holly's engines, which has been recently tested with satisfaction in that city. A beautiful illustration of it will be found in No. 10, Vol. XII., of the *SCIENTIFIC AMERICAN*. We are decidedly in favor of the steam fire engine; and a city true to its interests will never tolerate the reckless system so generally prevalent, especially in large cities. With good steam fire engines, well manned, and a strong body of mounted police, we believe millions of property might be saved, which is now either stolen by running thieves, or suffered to be destroyed through the careless neglect of undisciplined fire companies.

Improved Device for Upsetting Tires.

The accompanying engravings represent two views of the machine, Fig. 1 being a longitudinal vertical section, and Fig. 2 a plan or top view; the same letters refer to similar parts in both. A represents a flat bed or plate, which may be of cast iron, and supported at a suitable height by pedestals, *a*. On the upper surface of the platen, A, guides B are placed, between which ledges on the underside of blocks, C D, are fitted and allowed to slide freely. To the back sides of the blocks, C D, inclined oblique projecting ledges, C' D', are formed. These ledges extend from the top to the bottom of the blocks, and are fitted in oblique grooves which are made in a sliding plate, E, which is moved up and down by means of a screw, G. The upper part of the screw passes through the center of a curved bar, F, which has a thread cut in it, in which the screw works. H represents a plate permanently fixed to the bed, A. This plate has a slot made longitudinally in it, and a head, I, is placed on it, the lower part having a tenon on it that fits into the slot in H. The head is allowed to slide freely on the plate, H, and is moved backwards and forwards by a screw, K, which passes through an upright, H', fixed to the plate. The inner side of the head, I, has a dovetail projection, J', in it, and a curved plate, J, is secured to the head by ledges, J', formed on the back of it, the dovetail projection being fitted between the ledges which form a dovetail recess. To the ends of the plate, H, and directly between the two blocks, C D, an upright, H'', is secured by being dovetailed into the plate, L, which is curved to correspond with J. The blocks, C D, are attached to the horizontal plates, M N, which are in the same plane as H, these plates are slotted longitudinally as shown at O. Three slots are shown, but more or less can be used as desired. In the outermost slot of each plate there are two heads, N', N'', and M' M''. The inner sides of these heads are grooved, and wedges, R S, are fitted into the grooves. The innermost heads, M'' and N'' have a sharp edged jaw, M''' and N''', attached, and corresponding jaws, C'' D'', are placed on the blocks, C D, near their outer end.

The operation is as follows:—Suppose a tire is to be upset, the thinnest portion of the tire, W, Fig. 2, is heated and placed between the two curved plates, L J, the heated portion

being in the center of the plates. The plate, J, is then moved up to the tire by turning the screw, K; the wedges, R S, are then driven downwards, and the jaws are driven into the tire. These jaws serve as clamps, as they are only beveled on their outer sides. The blocks, C D, previous to clamping the tire, are dis-

HAZEN & GIBBS' DEVICE FOR UPSETTING TIRES.

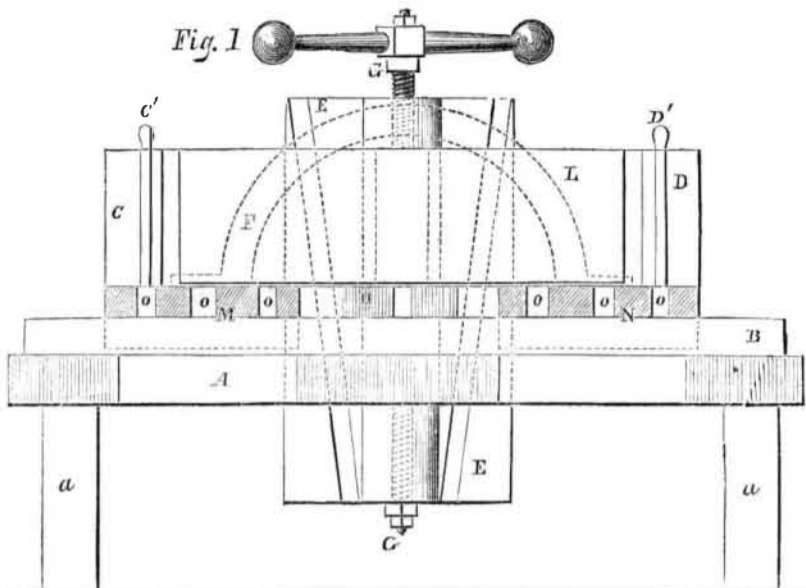

placed, E, and turning the screw, G; when the tire is clamped, the screw is turned in the opposite direction, and raising the block, E, forces together the blocks, C D, thus compressing the tire, or as it is technically called upsetting it. Straight bars can be upset, as

well as curved ones, by simply removing the curved bars, L and J, and placing straight ones in their place. Machines have been used before for upsetting the tires of wheels, but in them the blocks, C D, or their representatives, were brought together by right and left screws,

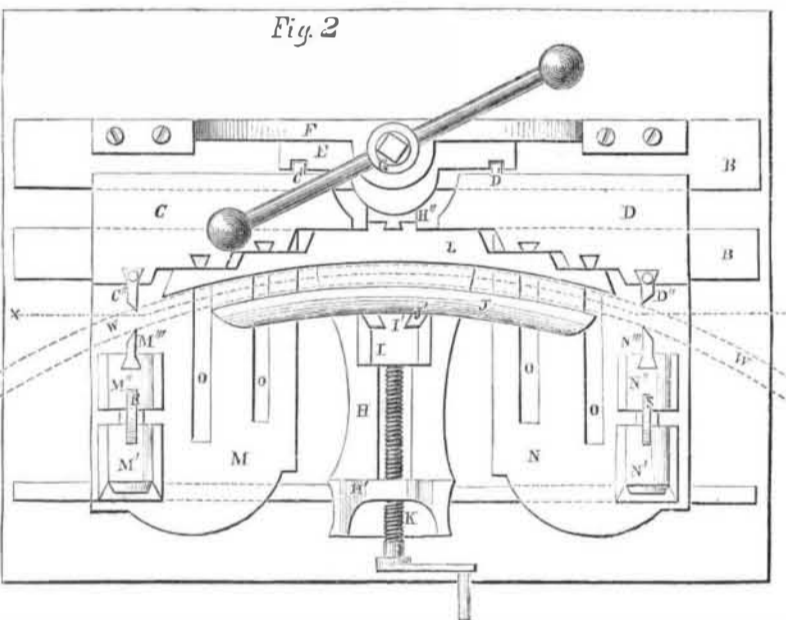

and as these had to be cut very fine to economize power, they soon stripped and became useless in this invention; however, when the power of the screw is used through the medium of the sliding plate, there is little danger of this accident, and moreover the

screw can be placed either forward or behind the inclined ledges as may be most desirable. For further information and particulars, address the inventors and patentees, Messrs. Hazen & Gibbs, Homer, Michigan. The machine was patented July 7, 1857.

BRYANT'S PATENT GAGE.

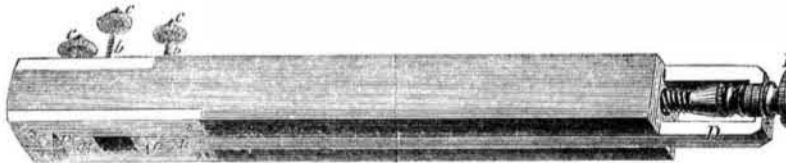

Our engraving shows a carpenter's gage, made under the patent granted April 11, 1857, to Joel Bryant, of No. 8 Clinton street, Brooklyn, N. Y. The novelty consists in attaching the points or markers, *a*, to holders, *b*, which are provided with screw threads; by turning the buttons, *c*, the markers, *a*, may be either projected or withdrawn from the face of the gage at pleasure. It matters not whether the markers, *a*, have round points or knife edges. One or more of the markers, *a*, and holders, *b*, may be rendered laterally adjustable by attachment to a slide, D, as shown in the drawing. This slide is moved by the screw, E, the thread of which enters a suitable nut at the extremity of the gage.

This is a simple improvement, but it is one

of much utility. A gage thus made presents a threefold advantage. When two of the markers is projected, it serves as a mortise gage; when they are withdrawn it is a single gage; and by removing the round points and substituting cutting edges (which may be readily done) the instrument becomes a cutting gage. The depth of cut given to the markers may be regulated at will. Address the patentee, as above, for further information.

According to a calculation recently made by M. Pouillet, it is found that the quantity of heat which this earth receives from the sun in a year is equal to the combustion of a stratum of coal the diameter of the earth and seven-

Literary Notices.

HALL'S JOURNAL OF HEALTH, FOR SEPTEMBER, contains, as usual, some good common-sense advice on subjects connected with health. The editor says his aim is to show how disease may be avoided, and that it is best when sickness comes to take no medicine without consulting an educated physician. We have a friend in this city who has been for some time past apparently afflicted with a deranged liver. He has been very friendly to the "family physician," and has gracefully swallowed his potions, under the belief that the diseased liver would soon be restored to its original soundness again. While laboring under a fit of *lous-steries*, we invited him to take a trip to the land of corn and wine, and on journeying to the society of an intelligent Eastern physician, who had practised the healing art for twenty-five years. Our friend made known his complaint, and the physician at once informed him that, after a long experience in such cases, he could give a prescription which he thought would greatly benefit him. Eager for relief, he seized the paper upon which the talismanic hieroglyphs were supposed to be written, which, when carefully manipulated by the apothecary, were to restore the liver, drive away the sallow countenance, and once more refresh the animal spirits. To his surprise he found the slip to contain only these words—"Take no more medicine!" He took the hint, and his experience has made him a wiser man, and he has, we believe, a better liver. This prescription may be of some service to other of our friends, who watch with interest for some newly-discovered nostrum, which will at once, as if by magic, restore dilapidated Nature. To such we can recommend *Hall's Journal of Health*.

A NEW PHASE IN THE IRON MANUFACTURE is the title of an illustrated pamphlet, of 84 quarto pages, containing valuable statistics and other useful and interesting information concerning the growth and present condition of the iron trade, both here and abroad; together with 250 engravings and descriptions (with prices) of the multifarious manufactures of the New York Wire Railing Co., whose agent, J. B. Wickersham, of 313 Broadway, this city, forwards copies of the above valuable work, postage free, on receipt of four three-cent stamps.



OF THE SCIENTIFIC AMERICAN.

VOLUME THIRTEEN.

TO MECHANICS, MANUFACTURERS, INVENTORS AND FARMERS.

In announcing the THIRTEENTH Annual Volume of the *SCIENTIFIC AMERICAN*, which commenced on the 12th of September, the Editors and Publishers embrace this opportunity to thank their numerous friends and subscribers for the encouraging and very liberal support heretofore extended to their journal, and they would again re-assure its patrons of their determination to render the *SCIENTIFIC AMERICAN* more and more useful, and more and more worthy of their continued confidence and good will. The undersigned point to the past as a guarantee of their disposition to always deal justly and discriminatingly with all subjects of a Scientific and Mechanical character which come within their purview.

Having entirely discarded the system of employing itinerant agents to obtain subscribers, the Publishers of the *SCIENTIFIC AMERICAN* propose to offer

ONE THOUSAND FIVE HUNDRED DOLLARS IN CASH PREMIUMS

for the fifteen largest lists of subscribers sent in by the 1st of January, 1858, said premiums to be distributed as follows:—

For the largest List	\$300
For the 2d largest List	250
For the 3d largest List	200
For the 4th largest List	150
For the 5th largest List	100
For the 6th largest List	90
For the 7th largest List	80
For the 8th largest List	70
For the 9th largest List	60
For the 10th largest List	50
For the 11th largest List	40
For the 12th largest List	35
For the 13th largest List	30
For the 14th largest List	25
For the 15th largest List	20

Names of subscribers can be sent in at different times and from different Post Offices. The cash will be paid to the orders of the successful competitors immediately after the 1st of January, 1858.

Southern, Western and Canadian money will be taken for subscriptions. Canadian subscribers will please to remit twenty-six cents extra on each year's subscription, to prepay postage.

TERMS OF SUBSCRIPTION—Two Dollars a Year, or One Dollar for Six Months.

CLUB RATES—Five Copies, for Six Months, \$4; Five Copies, for Twelve Months, \$8; Ten Copies, for Six Months, \$8; Ten Copies, for Twelve Months, \$15; Twenty Copies, for Twelve Months, \$28.

For all clubs of twenty and over, the yearly subscription is only \$1 40.

The general character of the *SCIENTIFIC AMERICAN* is well known, and, as heretofore, it will be chiefly devoted to the promulgation of information relating to the various MECHANICAL AND CHEMICAL ARTS, MANUFACTURES, AGRICULTURE, PATENTS, INVENTIONS, ENGINEERING, MILL WORK, and all interests which the light of PRACTICAL SCIENCE is calculated to advance. It is issued weekly, in form for binding; it contains annually from 500 to 700 finely executed Engravings, and Notices of American and European Improvements, together with an Official List of American Patent Claims, published weekly, in advance of all other papers.

It is the aim of the Editors of the *SCIENTIFIC AMERICAN* to present all subjects discussed in its columns in a practical and popular form. They will also endeavor to maintain a candid fearlessness in combating and exposing false theories and practices in Scientific and Mechanical matters, and thus preserve the character of the *SCIENTIFIC AMERICAN* as a reliable encyclopaedia of useful and entertaining knowledge.

Specimen copies will be sent gratis to any part of the country.

MUNN & CO., Publishers and Patent Agents, No. 128 Fulton street, New York.