

Improved Nut Chuck.

Machinists know very well that hexagonal, or six-sided, nuts take considerable time to finish, and that unless machines are employed the work becomes tedious and costly. In old times apprentices were made to chip and file all the six-sided nuts, but they were not always successful in their attempts. One half the nuts were spoiled from being variable in the size; no two angles were alike, and no single wrench would fit them. It was a great improvement on chipping and filing nuts when "slabbers," or milling machines, were adopted, for then all the nuts were alike in size and in the angles. The machine here shown is intended to face up six, eight, or four-sided nuts

steam power, pierces sixteen holes in the heel, after the 'lifts' are tacked together slightly, at the same time compressing the whole into a solid mass. Then the heel is taken to another machine, of similar construction, and the sixteen holes are pierced with one stroke by sixteen nails, and the heel fastened strongly to the sole of the shoe. The work is performed at a rate of one pair of shoes per minute, or faster if necessary; and the two machines, worked by one man and a boy, do the work of four heelers, thereby saving an outlay, at present prices for such labor, of fifty dollars per week. One hundred and ten operatives, men and women, boys and girls, are employed, divided into 'gangs' of ten or twelve

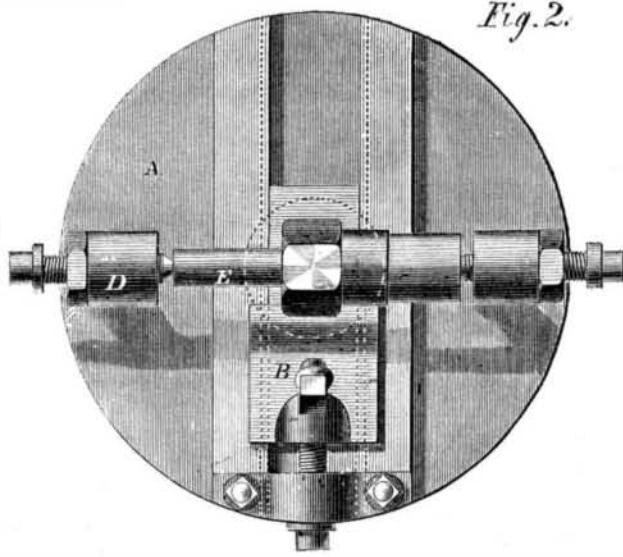
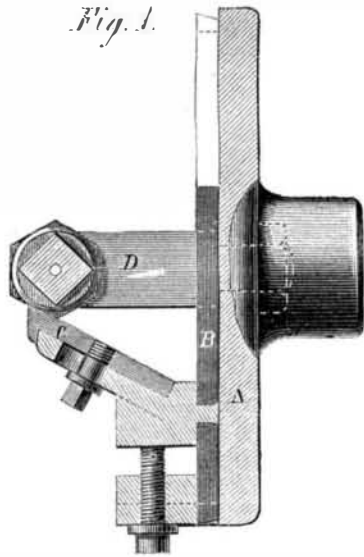

REILLY'S NUT CHUCK.

on a lathe, the same as is done on a slabbing or milling machine, and, as any mechanic can see at a glance, it will do the work to perfection.

A common face-plate, A, is fitted with a slide, B, which carries a gage, C, suited to the number of sides on the nut. This gage is shown in section of Fig. 1. From the face-plate two arms, D, project, which carry a mandrel, E, on which the nut is fixed as usual. These are the details, and the operation of them is easily understood. The chuck is screwed on to any common lathe, and the work of facing off the nuts can be done by a boy. Any sized nut can be faced off with the same gage for a guide. For by running the slide, B, out, and lengthening the gage, C, large or small nuts can be accommodated. The angle is always the same for hexagonal nuts of all sizes. This is an ingenious arrangement, worthy the attention of all persons making six-sided nuts. A number of nuts can be cut at once, but by working one at a time a beautiful finish is given, which is peculiar to this machine. The rays of light all converge in the center, as shown in the nut on the mandrel. Rough nuts can be quickly faced up on this chuck, by having two tool posts—one for roughing, the other for finishing. With a water finish the last cut is better than any nut we have ever seen, far surpassing emery polish.

This chuck was patented on May 30, 1865, by William A. Reilly; for further information address him corner of Third and Lawrence streets, Cincinnati, Ohio.

A Pair of Shoes Made in a Minute.

At Lynn, Mass., they make a pair of shoes in a minute; that is, the amount turned out at the end of the week is equal to a pair for every working minute of the time. This is done, says the Boston Commercial Bulletin, at Messrs. Bancroft & Purington's establishment:—

"Perhaps the most extensive establishment, in the details of its operations, is that of Messrs. Bancroft & Purington, who make about \$40,000 worth of ladies' boots per month. Mr. Purington has introduced the factory system of labor, and to decided advantage. One can witness in his rooms the entire process of making a shoe, from the rough side of leather to the full-finished article. Mr. P. has also introduced new machinery well worthy the attention of the trade. One of these machines, by the simple movement of a small lever, operated by hand or

each. Something more than a pair of shoes a minute are now being made during each ten working hours, and these are sent off to the purchaser every morning. The uppers are stitched in a separate establishment, and after a lot is received from the stitchers' hands, two days is ample time to prepare them for the sales-room of the purchaser."

FIELD'S CARRIAGE JACK.

A jack is an indispensable utensil to every one who owns a wheeled vehicle of any kind, for in order to grease the axles or remove the wheels from them they must be raised clear of the ground.

The engraving published herewith shows an improved carriage jack, by the aid of which any wagon or cart may be immediately raised and held securely without danger of falling. The details are as follows:—A represents a wooden standard which has a groove on each side to receive a metallic bar, B. In the latter there are holes and a pin fast to a chain, which passes through both parts, and supports them; in this way the jack can be fitted to any height of axle. When once brought to its position the lever, C, is thrown down—as shown in the engraving—and the axle rests on top of it. This machine is strongly made, and can be easily worked by any one. It was patented through the Scientific American Patent Agency, on April 25, 1865, by Austin W. Field, of Vergennes, Vt.; for further information address him at that place. State and county rights for sale.

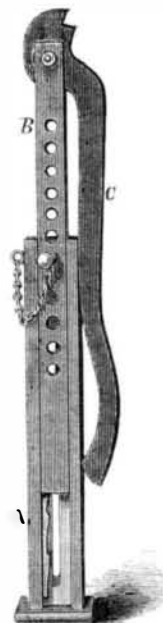

CORRECTION.—In the article on small steam boilers, published in our last issue, it was stated that the threads cut on the tubes should be 28 to the inch. This is an error; the number of threads should be 48—as a brass tube one thirty-second thick would not carry 28 threads.

TO
INVENTORS, MECHANICS, AGRICULTURALISTS,
THE ANNUAL
PROSPECTUS.

OF THE
Scientific American.

THE CHEAPEST AND BEST
MECHANICAL JOURNAL IN THE WORLD.
A NEW VOLUME OF WHICH COMMENCED
JULY 1, 1865

This valuable journal has been published nineteen years, and during all that time it has been the firm and steady advocate of the interests of the Inventor, Mechanic, Manufacturer and Farmers, and the faithful chronicler of the

PROGRESS OF ART, SCIENCE AND INDUSTRY
The SCIENTIFIC AMERICAN is the largest, the only reliable and most widely-circulated journal of the kind now published in the United States. It has witnessed the beginning and growth of nearly all the great inventions and discoveries of the day, most of which have been illustrated and described in its columns. It also contains a WEEKLY OFFICIAL LIST OF ALL THE PATENT CLAIMS, a feature of great value to all Inventors and Patentees. In the

MECHANICAL DEPARTMENT
a full account of all improvements in machinery will be given. Also, practical articles upon the various Tools used in Workshops and Manufactories.

HOUSEHOLD AND FARM IMPLEMENTS;
this latter department being very full and of great value to Farmers and Gardeners; articles embracing every department of Popular Science, which everybody can understand.

STEAM AND MECHANICAL ENGINEERING
will continue to receive careful attention, and all experiments and practical results will be fully recorded.

WOOLEN, COTTON AND OTHER MANUFACTURING INTERESTS
will have special attention. Also, Fire-arms, War Implements, Ordnance, War Vessels, Railway Machinery, Mechanics' Tools, Electric, Chemical and Mathematical Apparatus, Wood and Lumbermachines, Hydraulics, Pumps, WaterWheels, etc.

PATENT LAW DECISIONS AND DISCUSSIONS
will, as heretofore, form a prominent feature. Owing to the very large experience of the publishers, Messrs. MUNN & Co., as SOLICITORS OF PATENTS, this department of the paper will possess great interest to PATENTEEs AND INVENTORS.

The Publishers feel warranted in saying that no other journal now published contains an equal amount of useful information while it is their aim to present all subjects in the most popular and attractive manner.

The SCIENTIFIC AMERICAN is published once a week, in convenient form for binding, and each number contains sixteen pages of useful reading matter. Illustrated with

NUMEROUS SPLENDID ENGRAVINGS
of all the latest and best inventions of the day. This feature of the journal is worthy of special notice. Every number contains from five to ten original engravings of mechanical inventions, relating to every department of the arts. These engravings are executed by artists specially employed on the paper, and are universally acknowledged to be superior to anything of the kind produced in this country.

TERMS OF SUBSCRIPTION.
Per annum.....\$3 00
Six months..... 1 50
Four months..... 1 00
To clubs of ten or more the subscription price is \$2 50 per annum; This year's number contains several hundred superb engravings, also, reliable practical recipes, useful in every shop and household, Two volumes each year, 416 pages—total, 832 pages. SPECIMEN COPIES SENT FREE. Address,

MUNN & CO., Publishers,
No. 37 Park Row, New York City

PATENT AGENCY OFFICE.

MESSRS. MUNN & CO. have been engaged in soliciting American and Foreign Patents for the past eighteen years. Inventors who wish to consult with them about the novelty of their inventions are invited to send forward a sketch and description. If they wish to get their applications into Munn & Co.'s hands for prosecution they will please observe the following rules:—

Make a substantial model, not over one foot in size. When finished, put your name upon it, then pack it carefully in a box, upon which mark our address; prepay charges, and forward it by express. Send full description of your invention, either in box with model, or by mail; and at the same time forward \$16, first patent fee and stamp taxes. As soon as practicable after the model and funds reach us we proceed to prepare the drawings, petition, oath and specification, and forward the latter for signature and oath.

Read the following testimonial from the Hon. Joseph Holt, formerly Commissioner of Patents, afterwards Secretary of War, and now Judge Advocate General of the Army of the United States:—

MESSRS. MUNN & CO.—It affords me much pleasure to bear testimony to the able and efficient manner in which you discharged your duties as Solicitors of Patents, while I had the honor of holding the office of Commissioner. Your business was very large, and you sustained (and I doubt not justly deserved) the reputation of energy, marked ability, and uncompromising fidelity in performing your professional engagements.

Very respectfully, your obedient servant,
J. HOLT.

For further particulars see advertisement inside, or send for Pamphlet of Instruction. Address
MUNN & CO.,
No. 37 Park Row New York City.

FROM THE STEAM PRESS OF JOHN A. GRAY AND GREEN