

## New Inventions.

## Preventing Incrustation in Boilers.

R. McCafferty, of Lancaster, Pa., patented a new process for this purpose on the 14th of April, 1857. It consists in putting half a pound of black gum catechu in a boiler of 100-horse power, until the water becomes the color of pale brandy, and during the week the water is kept as nearly that color as possible, by adding small pieces of catechu from time to time. So long as this color is kept up, no incrustation forms; and in boilers where there is already an incrustation, its application gradually decomposes the lime, and it falls down, and is deposited in a kind of slush at the bottom, which may easily be washed away through the blow-off cock.

## Astronomical Discoveries.

Mr. Alvin Clark, of Cambridgeport, Mass., who was a portrait painter, has now turned his attention to the manufacture of telescopes, and with one of his own instruments he has discovered many double stars not hitherto known, and his observations have been communicated to the Royal Astronomical Society of London, who have confirmed some of his observations. It is to be hoped that an opportunity will be afforded him to construct a large telescope, his largest now being only  $7\frac{3}{4}$  inches in diameter. One which he made for the use of the Coast Survey, at a cost of \$2400, is said to have been so good that a pole three inches in diameter could be seen at a distance of fifty miles when the atmosphere was clear, but we think that this distance is almost too far to be true.

## New Method of Filling Front Teeth.

A very ingenious method of filling decayed front teeth, (first suggested, we believe, by Dr. Maynard, of Washington, D. C., inventor of the primer for fire-arms,) has recently been successfully carried into practice by A. J. Volek, M. D. It consists in setting a piece of enamel in the cavity of a decayed tooth much exposed, such as in an upper front one. The enamel for the cavity is of the same material as artificial teeth, and is formed to correspond with the cavity. It is fitted to the tooth loosely, then firmly walled or set in with a ring of gold foil. This is a much handsomer method of filling holes in exposed teeth than by the use of gold foil entirely, as the cavity thus closed only shows a surrounding hair line of gold; all the rest of it resembles the natural tooth.

## Improved Machine for Sawing Fellies.

All parts of wheels are now made by the aid of machinery. The hub or nave is turned in a lathe by steam, the spokes are cut by rotary knives operated by power, and the fellies are cut by machinery. The above engravings illustrate one of the most recent improvements in machines for sawing fellies, and its construction and operation will be fully understood by the following description, reference being made to the diagrams, of which Fig. 1 represents a vertical section of the machine, being taken through the line,  $x x$ , in Fig. 2, which is a plan or top view. Similar letters indicate the same parts in each. The invention consists in having two band saws attached, one to the outer and the other to the inner periphery of a wheel, by bands or straps, the outer saw being expanded or contracted by interposing bands between the saw and the periphery of the wheel.

A represents a frame to support the working parts; B is a shaft which is placed on the upper part of the frame, and carries two wheels, C and D, with a driving pulley, E, between. The wheel, C, is considerably smaller than D. E' is a band saw made of a strip of steel plate with teeth cut on one edge. This saw is secured around the outer rim of C, by means of a metallic band, F, the ends of which are looped and connected by a right and left screw, b, and nuts, a. By turning the screw,

b, in the proper direction, the band, F, may be made to clasp the saw tighter, and by turning it in the reverse way the band and saw will be slackened. The diameter of the saw, E', may be increased or diminished by interposing bands, c, between the rim of the wheel and the saw. The saw, E', and the bands, c, (their back edges) rest against the shoulder, d, on the outer surface of the rim of the wheel.

The cutting edge of the saw projects some distance beyond the rim. G is a saw precisely similar to E', and it is secured to the wheel, C, by the band, H, (exactly as E' is attached to C,) which can be expanded or contracted by the screw and nuts, e. The two saws, E' and G, project an equal distance from one side of the wheel, C. On the frame, A, and at one side of the wheel, C, a sliding carriage,

I, with a vertical bed, J, is secured. The bed, J, has movable dogs, f, applied to it at its upper end, stationary dogs being at the lower end of the bed. The movable dogs, f, may be connected with a lever, K, so that they can be raised or lowered. The staff or bolt from which the fellies are cut is secured against the bed, J, by means of the dogs, f; and when motion is given to the wheel, C, the bolt is

## VAUGHAN'S MACHINE FOR SAWING FELLIES.

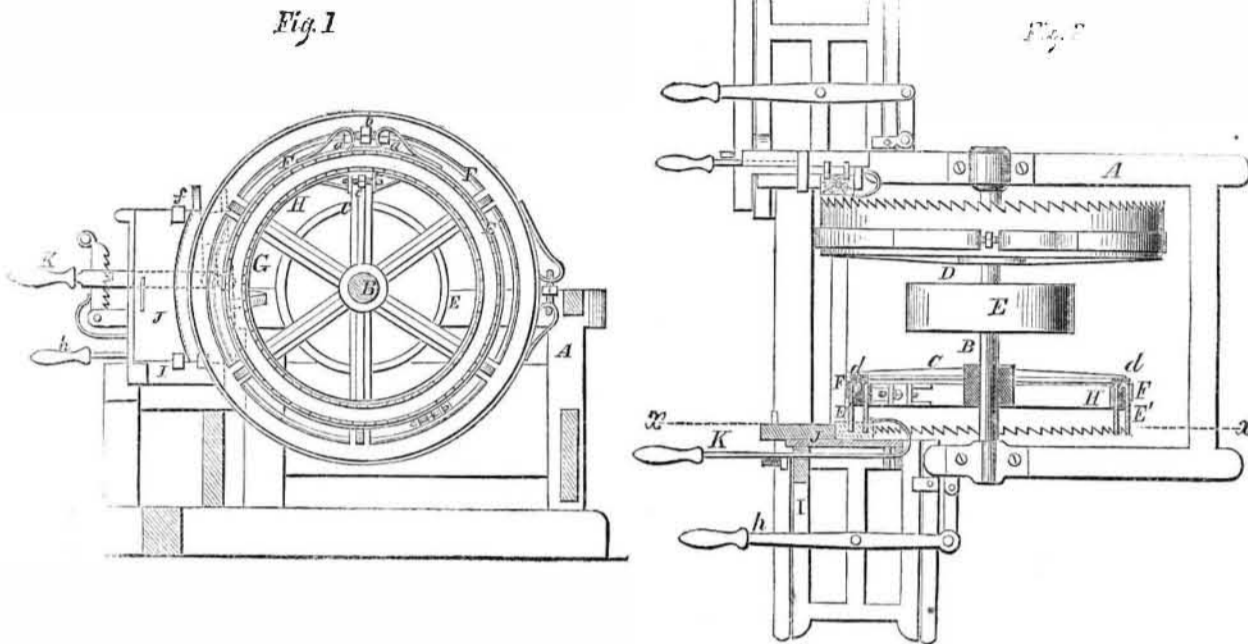

ed against the two band saws by moving the carriage, I, towards the saws by means of the lever, k. The two saws cut the fellies from the bolt exactly the shape they are required to be, and the thickness of the felly must depend on the number of rims between the saw, E', and the wheel, C, and fellies for wheels of different diameters may be cut by having a series of wheels, C, of various diameters. In Fig. 2, D

is a wheel precisely similar to C, only of a larger diameter.

This method of securing band saws to the periphery of wheels prevents the passing of bolts and screws through the saws at intervals, and the perforation of the saw blades to receive them is unnecessary, so that all the original strength of the saw blade is maintained, and it facilitates their removal

for sharpening or other purposes. The saws run clear and cool and cut very rapidly, leaving the felly smooth.

It was patented Nov. 17, 1857, by the inventor, Jacob Vaughan, of Exchangeville, Pa., who will furnish any further particulars. We noticed this invention on page 91 of the present volume of the SCIENTIFIC AMERICAN, when the patent was granted.

## GROSS'S PATENT EXTENSION TABLE.

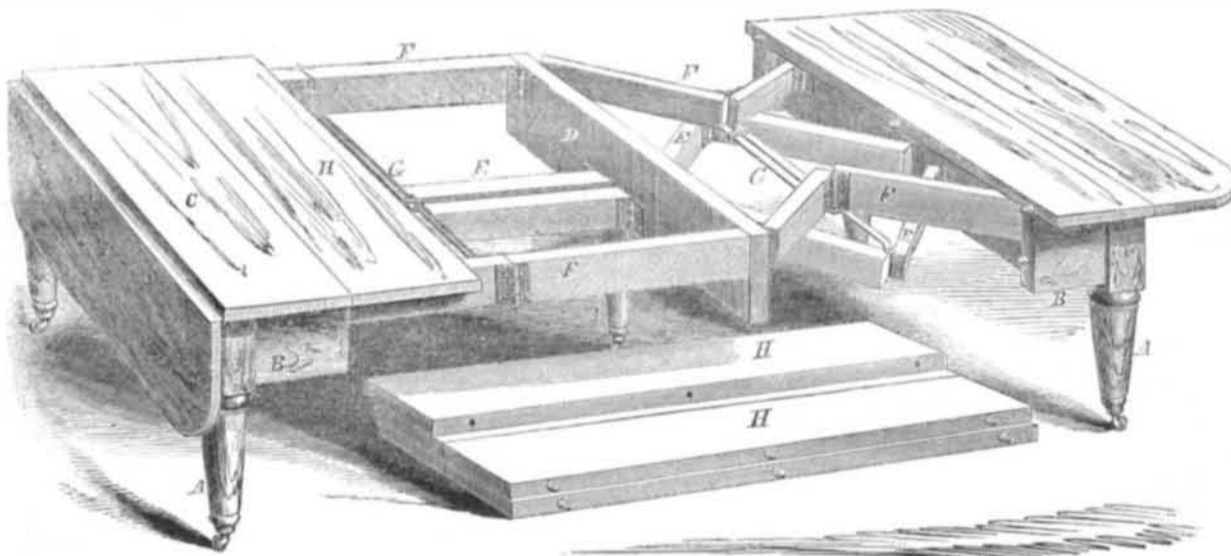

The common and laudable desire of all to have a house nicely and conveniently furnished, according to the taste of the individual, has given rise to the exercise of much ingenuity and artistic conception. In all houses there is a necessity for such articles as will be compact and neat, and occupy but little space when not in use, also that will, when required, spread out to accommodate the wants of a larger number than usual. This demand has called forth a supply in the shape of folding chairs, sofa bedsteads, extension tables, and many other articles of a similar nature.

The extension table we are about to describe, and which is represented in our engraving, is capable of being extended to four times its length, thus one made upon this plan would form a convenient side-board in a

recess of two feet wide, and could also be made available as a dining-table of eight feet long. The table proper is supported on four legs, A, supporting the ends and folding leaves, together with the sides, B, and permanent top, C. There is another leg, A', supporting a cross-piece, D, to which are attached by hinges on each side the jointed stretchers, F and E. The base of the hinge-pin of each side of the central hinge in F is attached to a rod, G, whose opposite extremity is connected with the central hinge-pin of E, thus connecting the two systems of stretchers; and the two rigid bars, G, are connected together by a small loose link passing around them. In any position, the table will be fully braced and supported. When the table is wide open, the stretchers assume the strong position seen in the left hand half of D, in the

engraving, and when semi-open, they are in the position indicated by the right hand half of the same. The auxiliary leaves, H, fit into one another by pegs and suitable holes and when not in use they can be packed away in any convenient receptacle.

It was patented Nov. 17, 1857, by the inventor, Henry Gross, of Tiffin, Ohio, who will be happy to furnish any further information.

## German Newspapers.

It is stated that there are ten times as many newspapers printed in the German language in the United States as there are in Germany. This is certainly creditable to the German population of our country, and they are usually a thrifty, peaceful class of citizens, especially outside of our large cities.