

## New Inventions.

## The Oreide of Gold.

We have received some samples of the above named material, described on page 308, this Vol. They were sent to us by Messrs. Holmes, Elton, Turrell & Co., of Waterbury, Conn., and No. 166 Fulton st., this city, who manufacture this alloy. In brilliancy and beauty of color it resembles gold. Its ductility is remarkable; some specimens are in the leaf form, as thin as some forms of gold employed for gilding, and they may readily be mistaken for the genuine metal. It is the most successful imitation of gold in color and malleable qualities we have ever seen.

## Improved Brick Press.

There are two kinds of brick—the "sun dried" and "burnt." The latter is the only sort capable of exposure in our climate, therefore no other kind is manufactured. They are composed of small slabs of tempered clay molded in presses, and afterwards exposed to a high heat—burned hard—in kilns, and are in reality, artificial stones, very convenient for exportation, and for handling by masons in the erection of buildings. They have been employed from the earliest times as substantial material for architectural structures, and always will be so employed, we believe, because they are fire-proof and weather-proof, and can be manufactured wherever clay, sand, water and fuel can be obtained.

At one period, and that not very distant, bricks were entirely molded by hand, involving the severest drudgery of human labor within our knowledge. Happily, the inventive genius of man, which has in so many cases proven beneficial in its results, has brought to the aid of human bone and sinew, those of iron and steel, in the form of brick presses. Several of these have been illustrated in our columns, and the accompanying engravings represent another to be added to the list. A patent was issued for this brick machine to Samuel Lillie, Jr., on the 17th of February last.

Fig. 1 is a perspective view, showing the interior of the tempering or pug mill, and fig. 2 is a vertical section of the entire machine.

A represents the frame of the press. The wet clay and sand employed to make the bricks are placed in the pug mill, which has a vertical revolving shaft, A', extending through its center, on which are beaters, a a. There are inclined scrapers, b b, on the lower end of the shaft; their lower edges are set very close to the bottom, c, of the pug mill, in which bottom there is an oblong opening, d. Within the framing, A, there is a minor frame, B, which has a rectangular box, C, fitted in its upper part; this box has an opening, f, in its top, corresponding with that in the bottom, c, of the pug mill; and there is a slide, D, in it, which opens and shuts off communication between the pug mill and box; it also contracts the passage as may be required. E is another box fitted to work freely up and down in the box, C. The upper end of box E is open, but in its bottom there is fitted a grating, F, the spaces of which correspond in width with the molds. A parallel bar, h, is attached to a plate secured to the lower end of box, E, at each side, and a vertical rack is united to each bar. A toothed sector, j, fitted on a transverse shaft, gears into each rack; the treddle, H, operates this shaft, and the sectors. There is a platform, I, secured to the back part of bars, h, and another platform, J, pivoted to and between these bars in front. R is a transverse roller in this platform. The front ends of bars, h, rest upon eccentrics, L, which are attached to the vibrating shaft of the swinging arms, K. There is a transverse shaft, O, in the lower part of the frame, B; at each side of it there is a link attached to a rod, on the back end of which there is a cross head, P, resting on the back platform, I. These are the component and relative parts of this press.

**Operation.**—Supposing the clay in the pug mill to have been properly tempered and worked by the beaters, a a, and ready for molding, the slide, D, is drawn out, to open

communication between the pug mill and the boxes, and box, C, is filled with clay. An empty mold box is now shown on the back platform, and a filled mold in dotted lines under the grating, F, of box, E. The operator now draws down lever M, which by the link O, and its side rods, draws forward the cross

head, P, which pushes the empty mold before it, and it in turn pushes out the full mold box on the front platform, J, and is then taken away.

The empty mold is now ready to be filled; by pressing with his foot upon treddle H, the operator, through sectors, j, elevates the

## LILLIE'S BRICK PRESS.

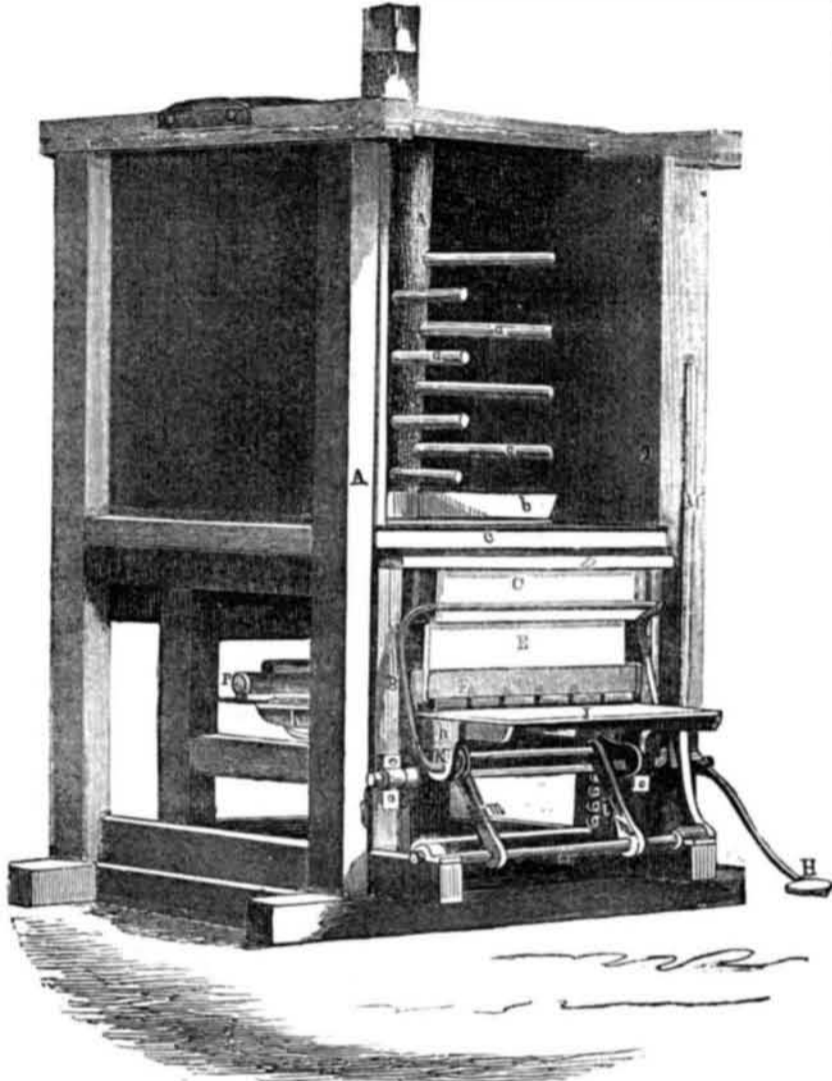

racks, i, forcing the empty mold and box, E, upwards into box C. The mold box is thus filled: the clay being forced through the grate, F, into the several molds in one box; the box E acting as a plunger. When pressure is removed from the treddle, H, the box, molds, and platform, descend by their own gravity. The lever, M, is then raised to the position shown, and the same operations repeat-

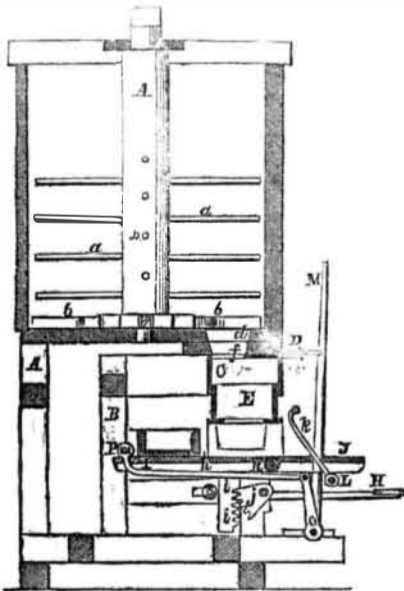

ed continuously. The front platform, J, being pivoted, if stones should get into the molds with the clay, and project above their upper surface, this platform can be lowered to allow the molds to be discharged.

This brick press is simple in its construction, it operates well, we are told, is not liable to get out of order, and can be worked with great ease. It is very compact, and peculiarly adapted for small brick yards, where it would be too expensive to employ steam or animal power to operate it.

For more information address the patentee Samuel Lillie, Jr., Fort Wayne, Ind.

## Williams' Axle for Carriages.

Many inventions have been brought forward, and a considerable variety are at this moment in use, for securing the wheels of carriages upon axles in such manner as to be absolutely reliable under all circumstances.

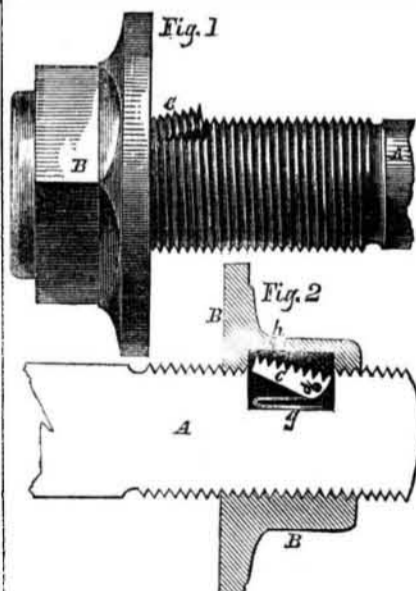

The incessant action to which such fastenings are exposed, the necessary looseness to allow of the revolution and a slight end play of the wheels, and the serious consequences liable to accrue from a sudden loss of a wheel in rapid traveling, gives great importance to the subject, and we take pleasure in giving publicity to the ingenious device under consideration as one entitled to especial attention.

Figure 1 is an exterior view, and figure 2 a

section of the extremity of an axle constructed according to this invention. A is the axle end, B the ordinary stout nut, with a broad flange attached to give a proper bearing against the wheel. A rectangular cavity is made in the axle, as represented, in which cavity is hung a lever, C, mounted on the pin d, and impelled outward by the spring g. The exterior face of this lever is formed with threads, so that when forced inward in opposition to the tension of the spring, g, it becomes a portion of the screw. At a proper point on the interior of the nut, a corresponding rectangular cavity is also formed as represented, so that when the nut is turned to a sufficient extent upon the axle the lever springs outward, and as the cavity is but little wider than C, the nut is firmly held in a manner entirely unaffected by any strain or jarring motion. When it is desired to remove the nut, any slender metallic point introduced through the hole, h, and pressed against C, drives it back to its first position, and allows the nut to be removed. Once started, the presence of the nut keeps the lever, C, down until the operation is completed, but until g is compressed by some object introduced through h, any force applied to turn the nut must be sufficient absolutely to shear off C, or it will produce no effect. It will be seen that the chances of accidentally releasing it are as slight as can well be imagined. The parts thus protected are also quite secure against both violence and dust.

The invention is not necessarily confined to the employment designated, as there are obviously many other situations to which it is well applicable. By prolonging the cavity in the nut, it may be set in various positions at will on the shaft to compensate for any wear either of the wheel-box, or of the face of the nut-flange. It is simply necessary, when so used, to depress the lever c, by introducing the point at h at each revolution. The nut by this means may be adjusted at will, but not to an extent less than a single revolution of the screw. A patent was granted for this invention May 26, 1857.

Further information may be obtained by applying to the inventor, Mr. Thomas W. Williams, No. 5 Forrest place, Philadelphia, or to Mr. Henry T. Hoyt, of the same city, who are assignees of the patentee.

## Agricultural Machines.

Messrs. Editors—Very true, you have done a great deal to introduce and recommend good agricultural implements. But if draining be the basis of good farming, as it is nineteen times in twenty, you have been building from the top to the bottom. Have a good—cheap if you can, but at all events good—ditching machine. That is now the agricultural want of this period. R. Richmond, Va., June, 1857.

[Our correspondent refers to our recent article on agricultural machines, on page 293. We must inform him that something has been done by us in the ditching machine line, as well as in every other line of agricultural machinery.

On page 12, Vol. 8, SCIENTIFIC AMERICAN, he will find the illustration of such a machine, and one on page 260, this Vol. If none of these possess the qualities desired by our correspondent—who is deeply interested in agricultural improvements—we call upon our inventors to supply the want.

## Phosphorescence of Insects.

The distinguished English chemist, Thornton E. Herepath, has been taking advantage of a recent trip to South America to collect and examine fire flies, in order to get at the secret of their luminosity. The commonly received opinion in regard to the source of the light emitted by insects, is that it is due to the slow combustion of phosphorus, resembling that produced by gently rubbing a match with the fingers. Mr. Herepath denies this, however, as he was unable, on the application of the most delicate tests, to detect the smallest trace of phosphorus in the bodies of these curious little creatures. His opinion is that the light is caused by the burning of a peculiar compound of carbon and hydrogen, in a special gland.