

# Scientific American.

THE ADVOCATE OF INDUSTRY, AND JOURNAL OF SCIENTIFIC, MECHANICAL, AND OTHER IMPROVEMENTS

VOLUME XII.

NEW-YORK, NOVEMBER 23, 1856.

NUMBER 11.

THE  
**Scientific American,**

PUBLISHED WEEKLY

At 123 Fulton street, N. Y. (Sun Buildings.)  
BY MUNN & CO.

O. D. MUNN, S. H. WALES, A. E. BEACH.

Responsible Agents may also be found in all the principal cities and towns in the United States. Single copies of the paper are on sale at the office of publication and at all the periodical stores in this city, Brooklyn, and Jersey City.

TERMS—\$2 a year,—\$1 in advance and the remainder in six months.  
See Prospectus on last page. No Traveling Agents employed.

**Patent Case.—Artificial Teeth.**

On the 14th inst. an important patent case relating to the dental art was decided in the United States Circuit Court, this city, Judge Nelson presiding. The suit was brought by G. W. Warren against N. B. Griffin, for infringing the patent of Dr. J. Allen, of Cincinnati, for setting mineral teeth by a compound resembling the natural gum, and forming a continuous gum with the plate. The defence set up was, that the invention was not new, that the specification was vague, and that there was no infringement.

The artificial teeth worn by Aaron Burr were produced in Court as ocular testimony against the novelty of the invention, and, we regret to state, on being landed to one of the jurors he let them fall, and they were broken. The set was constructed in Paris, and had a porcelain gum. The trial occupied five days, and a great number of dentists gave testimony *pro* and *con*. A verdict was given for the defendant.

**Blasting Stumps of Trees.**

The London *Mining Journal* states that various successful experiments have been made near London, in blasting stumps of trees with peculiar percussion cartridges, the invention of Capt. Norton.

It is a very easy matter to blast stumps of trees, but in our country we think the process would be far too expensive for farmers, at least on newly cleared timber land. Besides, the removal of the stumps is not the main evil, but their roots. Could our farmers plow close around the stumps on their lands, they would not complain much of the stumps themselves.

**Honolulu Mechanic's Mutual.**

We learn that there is a Mechanic's Benevolent Society in Honolulu. It has only 21 members, but it is a good and sound association. They have invested \$600, and have \$234 in cash in the hands of the Treasurer. There are plenty of benevolent societies in our cities that have ten times the number of members, and not one-tenth of the funds.

**Newfoundland Telegraph.**

The telegraph line between this city and Newfoundland is completed. It is 1715 miles long, with 85 miles of submarine cable. No difficulty has been experienced in working the instruments through the cable, thus showing it to be perfectly insulated. This line is to connect with the great Atlantic cable, which is expected to be laid down next summer.

**A Bad Place for a Seam.**

A locomotive boiler recently exploded at Middleborough, England, causing the death of the engineering draftsman and three laboring men, who were in the yard where the engine was standing, while steam was getting up. It came out in the evidence before the Coroner's Jury, that this boiler was constructed with a seam of plates running along its top, and to this faulty construction the accident has been attributed. There should have been a solid plate along the top instead of a seam with a row of rivets. This was the opinion expressed by engineers who gave their testimony as witnesses.

**IMPROVED OSCILLATING STEAM ENGINE.**

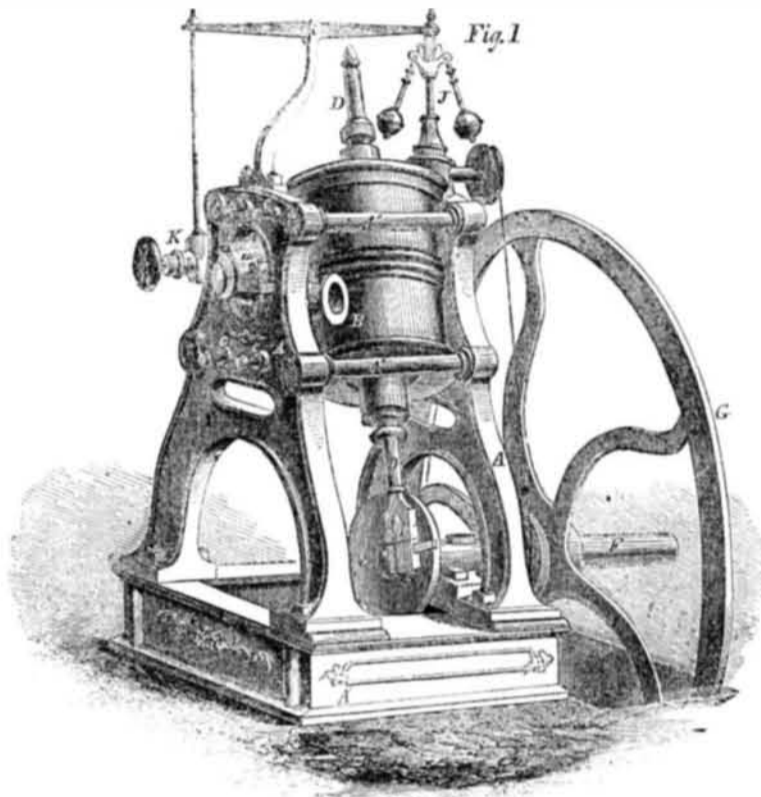

Improved Oscillating Steam Engine.

The accompanying figures illustrate an oscillating Steam Engine, for which Letters Patent were granted to Messrs. Cridge & Wadsworth, of Pittsburg, Pa., December 12th, 1854, but never before thus made public. Since that time these engines have been thoroughly tested, and have exhibited such advantages that they have come now into very extensive use in Pittsburg and vicinity as well as in more remote places. This engine belongs to that class of oscillating engines which are commonly called "side pipe" engines—the side pipe being the valve by which the steam is distributed in the cylinder.

Fig. 1 is a perspective view of the engine;

fig. 2 a side view of the cylinder, with a section of the side pipe and frame-work; fig. 3 is a face view of the side pipe; fig. 4 a section of the side pipe, with a reverse valve attached. Similar letters indicate like parts.

A A A' A" are parts which constitute the frame of the engine, B is the cylinder, whose trunnions, *b b*, rest in the boxes, *a a*, of the frame; C is the side pipe or valve; *c c* are four adjusting screws, by which the side pipe is kept up steam tight to the valve seat surfaces of the cylinder. There is a counter set screw, bearing against the opposite trunnion of the cylinder, and resisting or counteracting the reacting power of steam against the cylinder at the valve seats. D is the piston rod, pass-

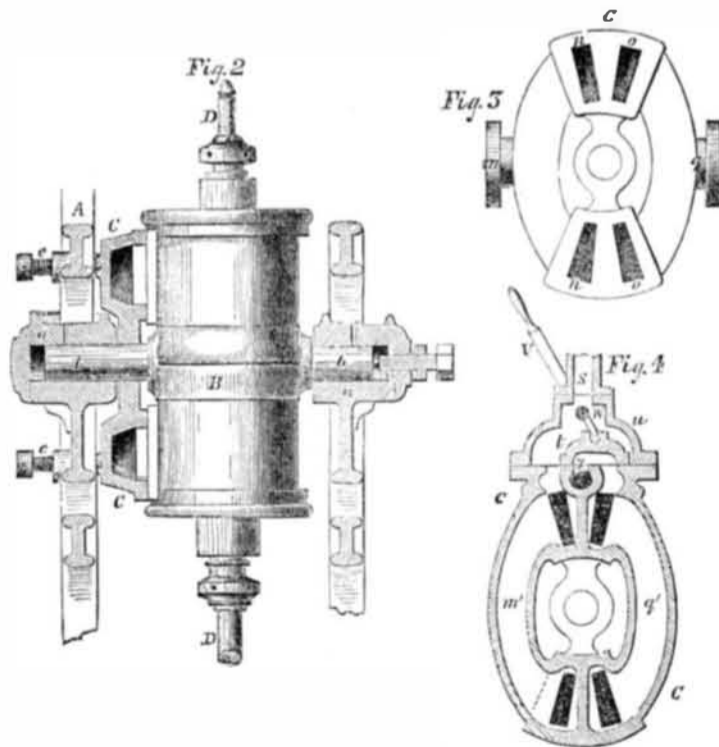

ing through both cylinder heads, which affords the advantage of an equal amount of steam pressure on both sides of the piston, and gives leverage to the piston rod, to set the cylinder into oscillating motion. E is the crank disk, connected by a strap joint with the piston rod, D. F is the fly-wheel shaft, and G the fly-

wheel. J is the governor, K the throttle valve.

The side pipe, as shown in fig. 3, is adapted for such engines as are not reversible. The steam enters at *m*, and is admitted into the cylinder by the openings, *n n*, alternately at the top and bottom, by the oscillations of the

cylinder, (the side pipes being stationary) and it is exhausted through the openings, *o o*, and the pipe, *q*. If the engine is desired to be reversible a valve, *t*, is used, as shown in fig. 4, which is enclosed in a steam chest, *u*, and which is set by means of a lever, V, and tooth, W, in such a position that the admission steam, (which enters the chest at S,) enters either into the side, *m'*, of the side pipe, the side, *q*, being then the exhaust side, or into the side *q'*, when the side *m'* will be the exhaust side. In both cases the escape steam passes through the cavity of the valve, *t*, and exhausts through the opening, X. By thus changing the receiving or escape sides of the side pipe at pleasure, the engine shaft will revolve in one or the other direction.

The main feature in this engine is the adjustable side pipe. In all the other side pipe engines the valves are always kept up to their seat and adjusted by means of a nut or screw in the center of the trunnion, but as the reacting pressure of the steam at the valve seats against the side pipe is changeable (which is caused by the steam communicating at one time with the cylinder, at another time being cut off, alternately at top and bottom) there is always a tendency of tilting in the side pipe which the adjusting screw in the center does not effectually counteract, hence the unequal wear of the side pipe and the difficulty of keeping it in good order.

In the above described engine, however, the re-acting pressure of the steam against the side pipe is counteracted directly, the adjusting screws being opposite the steam openings in the valve faces of the side pipe; this prevents any tendency of the side pipe to tilt or spring from the pressure of the steam, and keeps it up to the seat uniformly, no matter how much the re-acting power of the steam may change; in consequence of this the valve will have a uniform wear, and will, therefore, be always in excellent order. The application of the four set screws allow the valve to be adjusted at any place where it is wanted; the screws are set so that they just counteract the steam pressure, and keep the surfaces steam tight, and strained no more; the friction of the valve is hereby far less than in the side pipe, adjusted at the center, where it is necessary to strain the screw very hard to keep the valve faces steam tight, or in the ordinary slide valve engines, where the full pressure of the steam lays on the valves.

The whole construction of the described engine is elegant, compact, light, durable, and extremely simple. It is easy to build, as almost all the work on it can be done on the lathe.

Since the manufacture of these engines was commenced (about two years ago,) we understand that they have become great favorites where they are known, and have taken the precedence of others of the same class, because they obviate the evils with which the others are justly charged.

The patentees, whose advertisement will be found in another column, have met with merited success in their business since they commenced to construct them. More information may be obtained by letter or otherwise, addressed to them at Pittsburg, Pa.

**The Exploring Bark Resolute.**

The British bark *Resolute*, forming part of the Arctic Expedition in search of Sir John Franklin, was abandoned in the ice but was afterwards found by a New Bedford whaling vessel and brought home. It was purchased by our government, repaired at the Brooklyn Navy Yard, and sailed on the 13th inst. for Southampton, Eng., to be presented to the British government—a present from Uncle Sam to Uncle John—a very touching and appropriate gift indeed.