

New Inventions.

Machines for Planing and Jointing Staves.

The first annexed figures represent the improved machine of M. T. Kennedy, of Fallston, Pa., for which a patent was obtained on the 12th of last June.

Fig. 1 is a transverse section of the machine. Fig. 2 is a side view, and fig. 3 a top view. The invention relates to planing the outer sides of keg and barrel staves, and consists in the combination of a rotating disk provided with cutters, and a rotating clamp for holding the staves while being operated upon by the cutters. A represents the frame of the machine. B a horizontal shaft running in suitable bearings, *a a*, and having a circular metallic disk at one end provided with radial cutters, *b*, near its periphery, of which there may be four or more. The cutting edges of these cutters are on the outer side of the disk, as shown in figs. 2 and 3. D E are driving pulleys, by which motion is given to shaft, B, by a belt from some main driver. D' is a horizontal shaft having a driving pulley, E, at one end and a screw, F, at the opposite end. On the shaft, H, there are two circular disks, I I', permanently secured to the shaft, at a suitable distance apart, corresponding to the length of the staves to be planed. Around the disk, I, there is a band, J, having its inner edge serrated. K K are rods, the ends of which pass through the disks, I I'. Each rod has a lip, *c*, at one end. The outer ends of these lips are bent over the outer edge of the disk, I, and their edges are serrated. Around each of the rods, K, there is wound a spiral spring, L, which keeps the lips, *c*, over the edge of disk, I'. M M are stationary cams at the ends of a semicircular band, N, attached to one end of the frame, and at the back of disk I. The disks, I I', rods, K, and spring, L, with lips, *c*, form a rotating clamp.

Motion is given to disk, C, by means of a belt passing over either of the driving pulleys, D E, and motion is given to the clamp by a belt passing over the pulley, E, on shaft, D', the shaft H and clamp being rotated by screw F, and worm wheel, G. As the clamp rotates, the uppermost rod, K, will be acted upon by cam, M, which bears against its end and forces it forward, so that its lip, *c*, will be forced outwards from the disk, I', and the stave is then inserted between the lips, *c*, and the edge of band or loop, J. When the uppermost rod, K, passes the cam, M, its spiral spring, L, will draw the lip, *c*, of said rod firmly against the edge of the stave which will then be secured between the edge of the lip and that of the hoop or band, J. The staves are all secured in the clamp in this manner, viz: inserted as the clamp rotates, between the uppermost rod, K, and the hoop, J, the cam, M, permitting this by forcing out the lip and allowing the insertion of the stave. The clamp rotates in the direction of arrow 1, and the disk C in the direction of arrow 2, fig. 2. As the staves come in contact with the cutters, *b*, they are planed and dressed while passing round on the clamp. When the ends of the rods come in contact with the lower cam, M, fig. 2, the lips, *c*, are again forced forward or out from the disk, I', and the dressed stave then falls from the clamp. This is a simple and good operative machine. The claim is for the disk, C, and the clamp, the latter being formed of a series of rods, K K, passing through the disks, I I', and provided with springs and lips, operated and formed as described and represented.

The succeeding figures represent the improved stave jointing machine of M. T. Kennedy, for which a patent was granted to him on the same date as the one for his above described stave dresser. The nature of the invention of this machine consists in the combination of two reciprocating planes and an adjustable clamp, constructed, arranged, and operated as will be described, for jointing staves for barrels, kegs, and such like purposes.

Fig. 1 is a vertical longitudinal section of the machine; fig. 2 is a transverse vertical section of it, and A' A' A' embraced in fig. 3, show three staves—one partly, and two finished.

A is the frame of the machine. B is a shaft running in suitable bearings, and having a pulley, C, and a fly wheel, D, at one end. E is a

connecting rod united by a pin eccentrically to the fly wheel. The opposite end of this rod is attached to two reciprocating planes, F F, which work in guideways on the front part of the frame. The planers, F F, are formed by inserting cutters, *a a*, in metallic plates, *b b*, which are placed a suitable distance apart, and have their upper edges inclined outwards, as shown in fig. 2. The ends of these plates are attached to blocks, H H, which work on guides. I represents a clamp attached to the upper end of rod, J. This rod passes through a socket,

K, in the upper part of frame L, which is secured by bolts, *c c*, to frame, A, the lower end of frame L being also secured to the base of frame A. The rod, J, has a small cross bar, M, passing through it, the ends of which work in grooves in the frame as shown in fig. 2. The lower end of rod J, rests upon the end of a treddle, N, which is connected to another treddle, O, by a strap, O', passing over pulley *d*. The clamp, I, is formed by two metallic plates, *e e*, connected by end pieces, *ff*, as shown in fig. 1. Between these plates there is placed

another plate, *g*, which has a bolt, *h*, at each end. These bolts pass through the upper plate *e*, and have nuts, *i i*, upon them. A plate, *j*, is also placed above the upper plate, *e*, the nuts, *i*, securing it by the bolts, *h*. A cam, *k*, is inserted in plate *j*; it is provided with a handle, *l*, and its edge bears upon the surface of the upper plate, *e*.

The staves to be jointed are secured in the clamp, I, by placing them—one at a time—between the upper plate, *e*, and plate *g*, and by moving or turning the cam, *k*, which secures

KENNEDY'S PATENT MACHINE FOR PLANING STAVES.

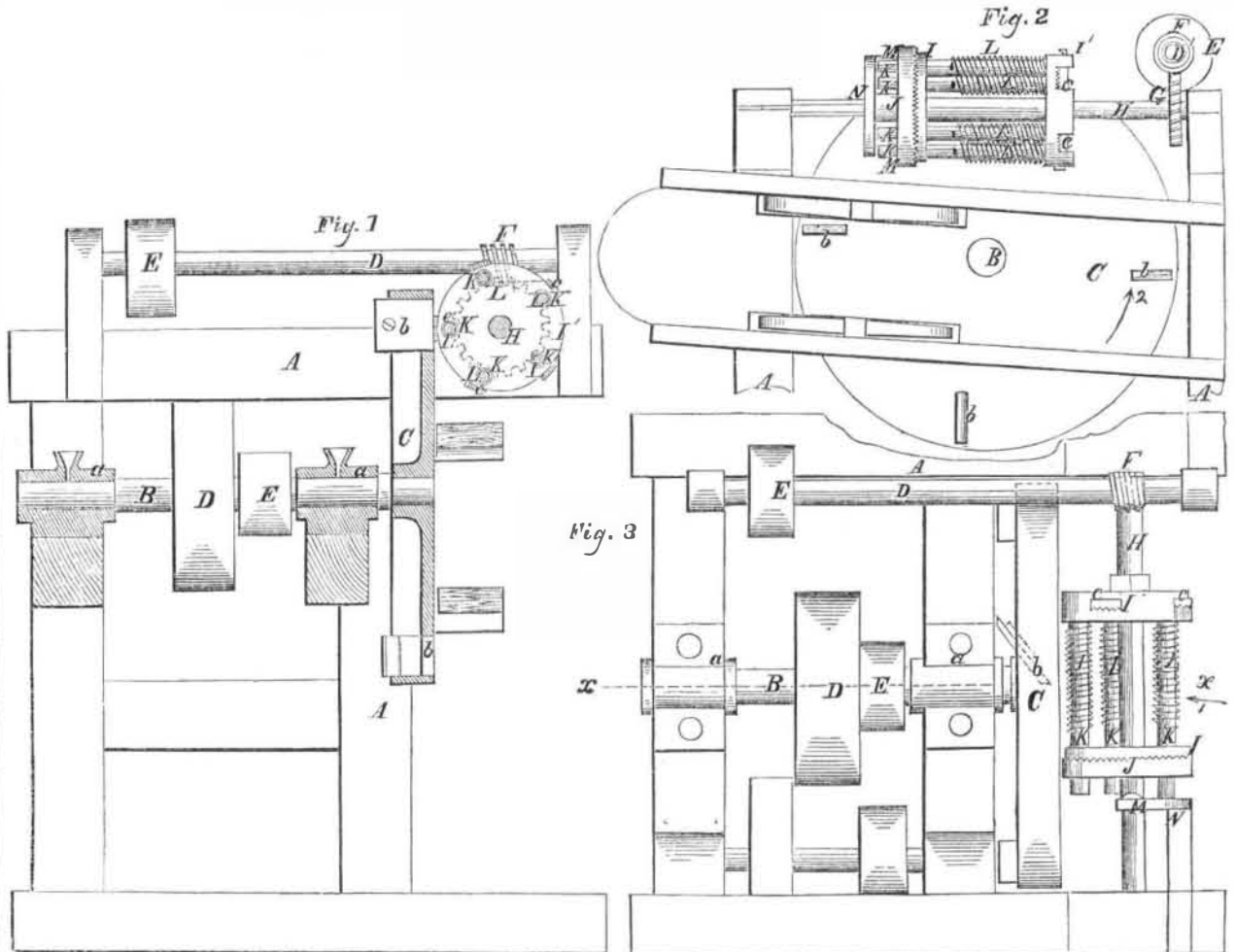

each stave firmly between the two plates named. The lower end of the frame, L, is then moved towards the back part of frame, A, so as to give the clamp, I, an inclined position, as shown in fig. 1. Motion is then given to shaft B, and the clamp, by its own gravity, settles

down between the two planers, F F, when the edges of the stave are brought into contact with the cutters, *a a*, which have a reciprocating motion given to them by the action of the connecting rod, E, which is attached to the planers, F F. The edges of the stave are

planed of a taper form, and so is the stave itself, as shown by A'. The foot is pressed upon the treddle, O, and the clamp, thereby, is elevated above the plane when the position of the stave is reversed by turning the clamp half way round. It (the clamp) is then allowed to descend, and

KENNEDY'S PATENT STAVE JOINTER.

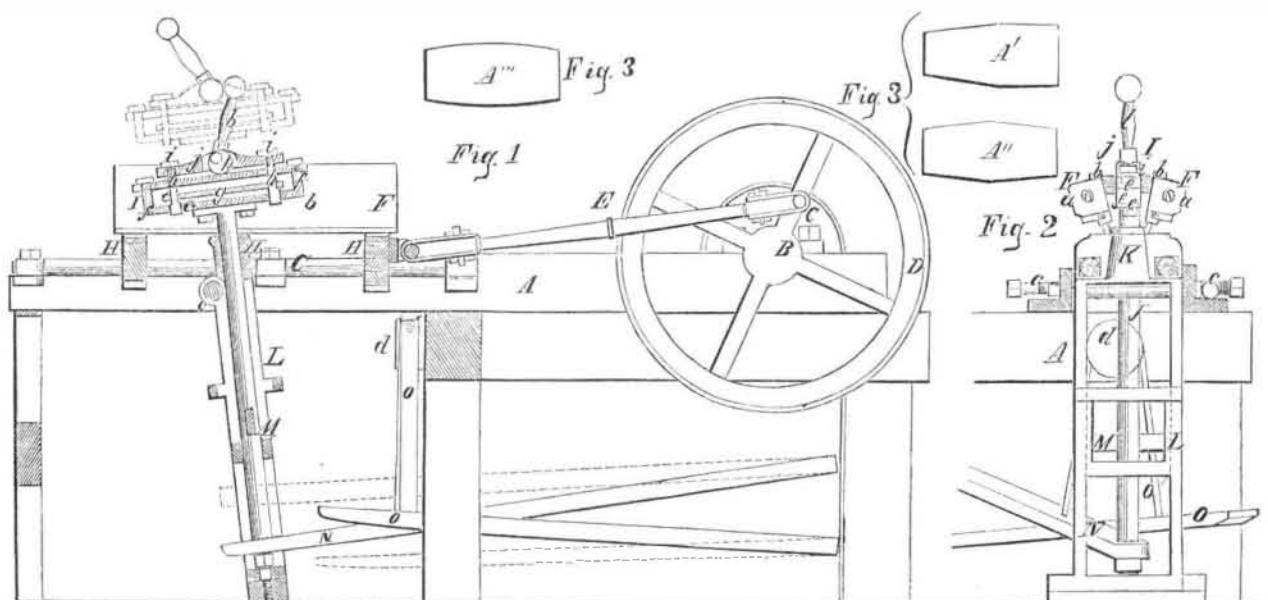

the opposite end of the stave is jointed in a similar manner to the first, when it will be of the form of A'. If the staves require to have rounded edges, as shown by A'', they are bent or sprung upwards at their centers in clamp I. More or less taper may be given to the staves, by adjusting frame L, so that the clamp, I, may be more or less inclined. Some kinds of staves such as those used for pails, kegs, &c., require one taper only, and these of course are not reversed in the clamp. This machine is extremely simple, not liable to get out of repair, nor is it expensive to manufacture. For making tight

vessels, it possesses great advantages, as the planes act upon the staves from the center to the ends, thereby working with the grain of the wood and making a very smooth joint.—Mr. Kennedy is now manufacturing lead kegs at the rate of 50 per hour, upon a single set of the above described machines.

More information respecting them may be obtained by letter addressed to him at his residence, Fallston, Beaver Co., Pa.

Iron Steamboats at Wilmington, Delaware.

One of our correspondents states that there

are, among other industrial works existing at Wilmington, Del., two establishments for the construction of iron vessels, in which 600 men are employed. Within the past year they have turned out ten iron steamboats and one schooner.

White's Reporter, of Louisville, Ky., speaks in a most flattering manner of the plow manufactured by Thos. E. C. Brinly, of Simpsonville, in that State, stating that it has taken the premium at every Fair in Kentucky at which it has been exhibited.