

# Scientific American.

THE ADVOCATE OF INDUSTRY, AND JOURNAL OF SCIENTIFIC, MECHANICAL, AND OTHER IMPROVEMENTS.

VOLUME X.]

NEW-YORK, SEPTEMBER 8, 1855.

[NUMBER 52.

## THE Scientific American,

PUBLISHED WEEKLY

At 123 Fulton Street, N. Y. (Sun Buildings.)

BY MUNN & COMPANY.

O. D. MUNN, S. H. WALES, A. E. BEACH.

### Agents.

Federhen & Co., Boston. Dexter & Bro., New York  
A. Winch, Philadelphia. E. E. Fuller, Halifax, N. S.  
A. G. Courtney, Charleston. S. W. Pease, Cincinnati, O.  
Avery, Bellford & Co., London. M. Gardissal & Co., Paris

Responsible Agents may also be found in all the principal cities and towns in the United States.  
Single copies of the paper are on sale at all the periodical stores in this city, Brooklyn, and Jersey City.

TERMS—\$2 a year.—\$1 in advance and the remainder in six months.

### Sawing Machinery.

This figure is a perspective view of the machine of Benjn. Fulgham, of Richmond, Ind., for sawing out boards, scantling, laths, stuff for hoe and broom handles, &c., direct from the log, or from bolts.

As here represented, it combines improvements for which two patents have been granted, and it is very perfect in its operations. The first patent was obtained on the 19th of Sep., 1854, and illustrated on page 76, this volume SCIENTIFIC AMERICAN. It embraces the features for sawing out stuff by both the forward and backward motions of the saw carriage.—The second patent was granted on the 24th of July last, and its claim, published on page 370, embraces an ingenious method of self-feeding the log to the saws.

A represents a rectangular frame, at the upper part of which is a transverse shaft, B. On this shaft there is hung a vibrating frame, C, on the outer end of which there is hung a counterpoise weighted box, D. To its inner end there is hung the pendant frame, E, which has a saw shaft at its lower end, the said shaft passing through the saw carriage, G, and working in suitable guides attached to the feed frame, G'. The shaft, F, secures the lower end of the pendant frame, E, to the frame, G. The vertical circular saw, H, is secured to one end of this shaft, and to one end of frame, G, is secured a vertical shaft, I, having a horizontal circular saw, J, secured on its lower end. From pulley K, on shaft B, a band, a, passes around pulley L, on shaft M. From another pulley on said shaft, a band, b, passes around a pulley (hid from view) on the saw shaft, F. This pulley has also a belt, c, passing from it around a small drum near the back end of the carriage; another crossed belt, d, passes around this drum and a horizontal pulley on the saw shaft I. On the off end of shaft B, there is a pulley from which a belt, e, passes around a pulley, T, on shaft, S, at top and front end of the frame, A. There are two other pulleys, U, on the high end of shaft, S, from which a cross belt, f, and a straight belt, g, proceed, and pass over two loose pulleys, h h, on the shaft, V, at the front end of the frame. Between the two pulleys, h h, there is a clutch, indicated by i, but hidden, which is operated by the backward and forward movements of the saw carriage, to throw these pulleys alternately into and out of gear with shaft V, around which passes the cord over pulleys from end to end of the frame, A, to reverse the motion of the shaft, V, and thus make the saw carriage traverse alternately back and forth. This is done by having dogs on the side of the frame, G, which strike studs on the vibrating long rod, w, when the carriage has moved to each end; to rod, w, is connected a shipper (hid from view), which operates clutch i, and the pulleys, h, reverses the motion of shaft, V, and the saw carriage alternately, continually back and forth. The studs on rod w can be set to give the carriage a shorter or longer traverse, as may be desired. The vibrating frame, C, allows the pendant frame to travel or oscillate with the carriage, so as to retain the belt, b, perfectly taut all the time. This is a very ingenious arrangement. The saws cut while

## MACHINE FOR SAWING BOARDS, SCANTLING, &c., DIRECT FROM THE LOG.

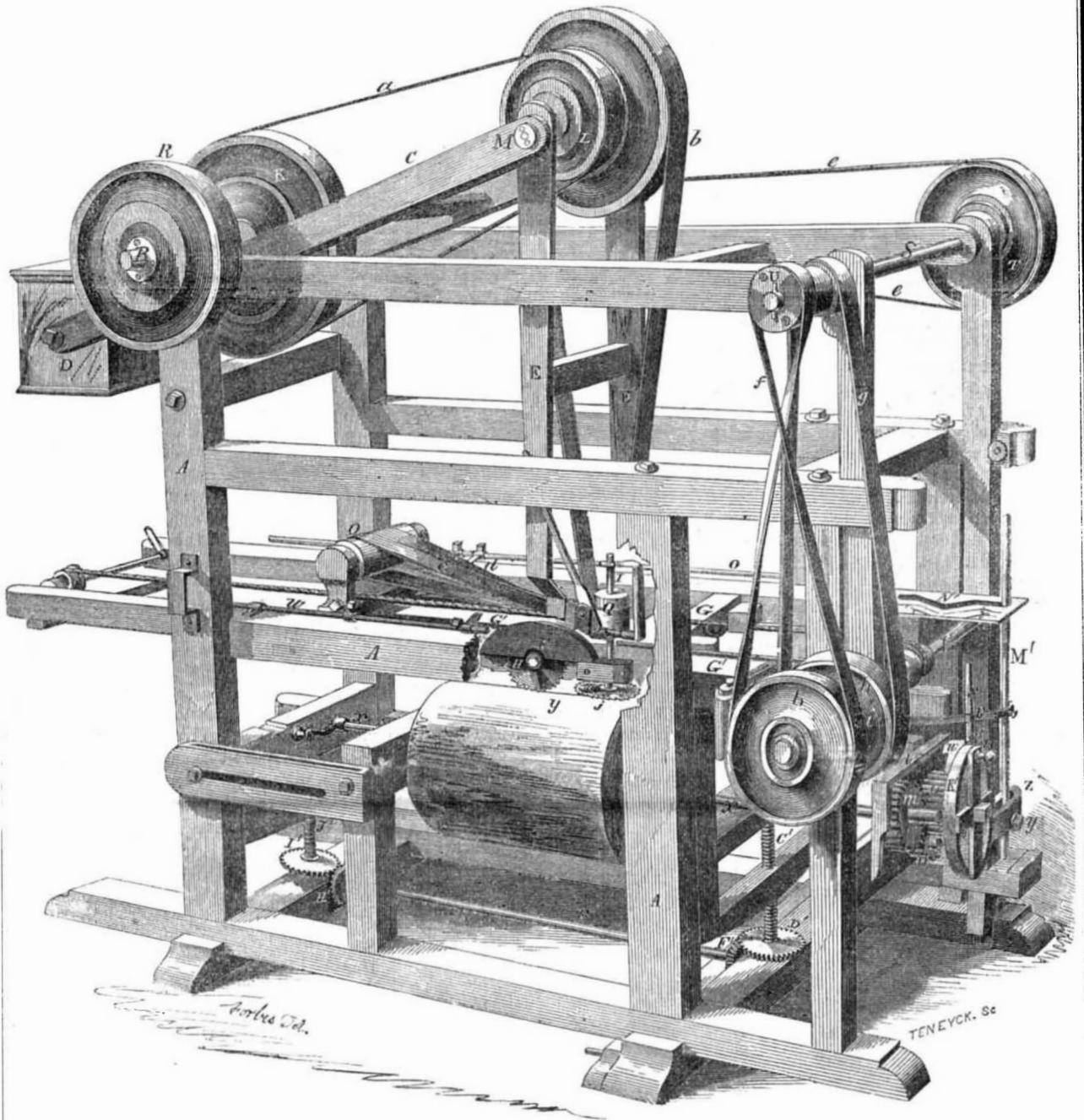

their carriage is traveling back and forth in both directions. The one saw, J, cuts in the log horizontally, the other, H, vertically, so as to cut out a complete board, or plank, or slat, or strip for a hoe or other handle, at each movement of the carriage. The method of operating the saws and the carriage to cut during both motions of the carriage, is embraced in the first patent of Mr. Fulgham. The method of feeding and cutting from the log is that embraced in the second. This is accomplished by feeding the saw frame down the requisite distance at the end of every traverse of the carriage, also to move the log a proper distance so as to take a new cut. The method of doing this we will now describe:

In the permanent frame, A, are two spindles or shafts, x x, between which the log, y, to be sawed is secured, and receives a proper intermittent rotary motion for every new board or strip to be sawed off. To the outer end of one shaft there is attached a pinion, m, which gears into a pinion, n, attached to the frame, A. The pinion, n, gears into a smaller one, o, attached to the end of another shaft (hidden from view), which has a bevel pinion on its inner end. This bevel pinion gears into a corresponding one on the upper end of a vertical screw shaft, C', which has a bevel wheel, D' at its lower end. This screw shaft, C', passes through a cross piece or bolster at the front part of the frame, G'. The bevel wheel, D',

gears into another, E', at the end of shaft, F', which has a corresponding gearing, H' P', at the opposite end. The screw shaft, J', passes into a cross piece or bolster at the back part of frame G'. These screw shafts, C' J', work in nuts in the frame, G', and support it, consequently, as they are moved in one direction, they will feed down or lower the saw frame a certain distance, to make the saws take a cut into each new layer of the log.

The mode of feeding down the saw frame is ingenious and peculiar. To the outer end of the shaft of the cog wheel, o, there is secured a wheel, K', having a smooth rim, and adjoining it on the off side there is placed a plate having a bar, s, attached to it by a pivot, t. This bar has an inclined recess, s', cut in it, in which the rim of the wheel, K', fits. The plate of this bar has a spring, w, attached to it, which keeps the edges of the inclined recess binding on the periphery of the wheel, K'. The upper end of bar s, passes through a socket, v, on the outer end of a small arm, the inner end of which is attached by a pivot to the upright vibrating lever, M'. The upper end of this lever, M', passes through and works in a V-shaped slot in a plate, N', which is attached to the end of the longitudinal rod, O, fitted in guides in frame, G'. The lower part of lever M', is provided with a slot, z, through which a pin is inserted, and passing into frame, G'.

OPERATION—The log, y, is centered between

the shafts, x x. Motion is then given to shaft B, by a band passing over pulley, R, from a water wheel or steam engine, and the saws, H J, are rotated, and the saw frame or carriage, G, drawn along between guides in the frame, G', and the saws cut a strip out of the log leaving a vertical shoulder on it. When the saws in their carriage have reached the end of the log, the clutch, i, is operated as has been described, and the carriage moves back, the saws cutting a strip on the return movement also. Just before the return motion of the saw carriage, G, the plate, N, is shifted forward by a dog on the frame, G, striking a stud on the rod as the carriage is moving. The plate, N', will then push the rod, M', in the V-shaped slot, and make it vibrate, thereby moving the bar, s, and the wheel, K', when the log will be turned round a suitable distance on its centers, and the frame, G', which sustains the carriage, G', will be lowered a small distance by the bevel gearing operating the screw rods, C' J', which sustain the frame, and which work in nuts in the bolsters of it. These movements—the log partially round and the frame, G', slightly lowered—feed the log to the saws for the succeeding cut. This causes the log to be sawed in a spiral form from the circumference to the center. The lowering of the frame, G', at every traverse of the carriage, G, determines the width of the stuff to be sawed. Various kinds of stuff, therefore, can be sawed in the

machine by varying these movements. As the saws approach the center of the log, the feed motion necessarily must be increased to saw stuff of an equal thickness, as the log, being the smaller, cannot pass through so much space with the same amount of its shaft's rotation. This is provided for by the lever, M', passing through the slotted plate, N', which is attached to the frame, G', and of course as this frame is depressed, every stroke of the plate, N', will increase the movement of bar s and give it a longer stroke, like a ratchet, to give a greater amount of motion to the shaft of the log and frame, G'. A square bolt may be placed in a frame made for the purpose, and sawed into strips like the log, only it has to be shifted crosswise under the saws, when a series of strips or boards are cut down vertically through it by the depression of frame, G'.

In this machine, laths, hoe, and broom handle stuff, &c., as well as boards, scantling, &c. may be sawn out directly from the log, requiring no re-sawing. The machine is very compact, as it cuts both ways, consequently its carriage is only half the length of those which cut by the log instead of the saw moving. It is self-acting, and can be so arranged by a cut-off plate for the slot in plate N', as to shorten the stroke of the lever, M', for any width of stuff to be sawed. It will be understood that the rod, O O, and plate, N', on it, are operated by dogs striking studs during every traverse of the saw carriage. It is certainly a labor-saving sawing machine, as the log or bolt, y, has but to be centered in it, and the machine set in motion, when it will work away until the entire log is cut up, without any handling or work by the operator. We have seen a large working model of one of these machines in operation in this city, and was pleased with its performance. It will be on exhibition at the Fair of the American Institute, to be held in this city in the early part of next October, where all interested in valuable and new improvements in sawing machinery will have an opportunity of witnessing its operations.

More information respecting it may be obtained by letter addressed to J. M. Hutton, Richmond, Indiana.

Chase's Fancy Window Blinds.

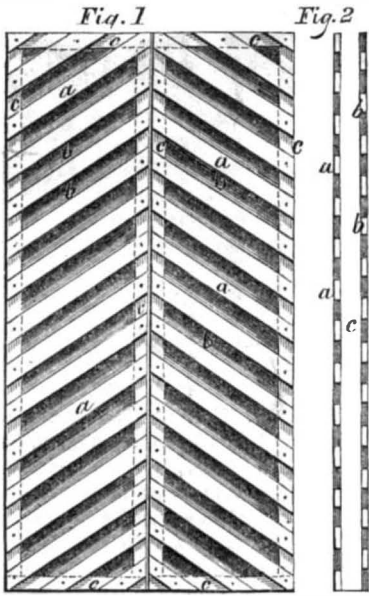

The accompanying figures represent the fancy window blind of Frank Chase, of South Sutton, New Hampshire, for which a patent was granted to him on the 17th of July last.

Fig. 1 is a front view of a pair of blinds, and fig. 2 is a transverse section or edge view. A rectangular frame, c c c, for each blind is made by securing side stiles to the top and bottom rails in any common way. To one side of the frame a series of oblique slats, a, are nailed as shown, leaving spaces between them. On the other or back side of the frame, a series of slats, b, are nailed opposite the spaces between the slats, a. All these slats are nailed in at the same angle, and as each series is secured on the opposite sides of the frame, they allow the air to pass through the spaces between them—which are equal to the thickness of the stiles—but will prevent the direct rays of the sun penetrating into the room, and yet will admit reflected light between the spaces named. These slats, a b, it will be understood, are fixed and not the same as the vibrating ones of venetian blinds. They may be put on in differ-

ent fanciful positions from that shown and yet maintain the same characteristics, such as radiating from a center, forming a star, or nailed horizontally, to present nearly the same appearance as common blinds, the frames being

hung in the same manner. Their advantages consist in being easily made, and at a small expense, and in being strong and durable. No tennons, mortises, rods, or wires, are required in constructing them. They are of an orna-

mental character, and as substitutes, at least, for shutters, their advantages are evident.

More information may be obtained by letter addressed to the patentee, at South Sutton, N. H.

MACHINE FOR SAWING DOWNSTANDING TREES, AND LOGS.

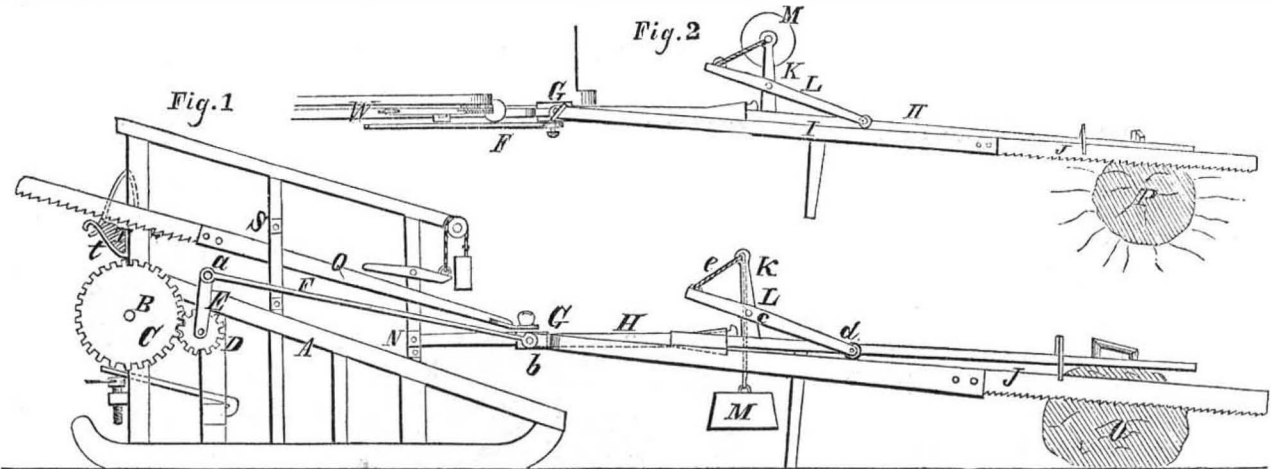

The accompanying engravings are views of a new machine for sawing down standing trees or logs, for which a patent was granted to Matthew Ludwig, of Boston, Mass., on the 17th of July last. Fig. 1 is a side view of the machine, and fig. 2 is a top view of it, shown in a different position from that of fig. 1. Similar letters refer to like parts.

A, fig. 1, represents a suitable framing on which an ordinary inclined horse power is placed, to operate the machine. B represents the shaft of the upper roller of the endless belt, having on one end a toothed wheel, C, which gears into a smaller toothed wheel, D, the axis of which is attached to the framing. The toothed wheel, D, has a crank arm, E, attached to it. To the end of the crank arm there is attached by a pivot, a, one end of a connecting rod, F. The opposite end of this connecting rod is attached by a screw, b, to a sleeve, G. This sleeve is of a rectangular form, and is fitted loosely on a rectangular bar, H, one end of which is secured to the framing. The opposite end of the bar, H, is attached to the log

or to the standing tree to be sawed down, as will be presently shown. I represents a bar, one end of which is attached to the sleeve, G, and the opposite end is attached to a saw, J.

To the bar, H, there is attached an arm, K, which has a lever, L, secured to it by a screw or pivot, c. The inner end of this lever, L, is provided with a friction roller which bears against the bar, I, and the opposite end of the lever has a cord attached to it, said cord passing through a hole in the outer end of the arm, K, and having a weight, M, attached to its lower end. The inner end of the bar, H, is fitted in a socket, N, attached to the framing, A, so that said bar may be detached from the frame and turned or reversed.

If logs are to be sawed for firewood, the outer end of the bar, H, is clamped in any proper manner to the log represented by O, the log set in a horizontal position. In this case the arm, K, is in an upright position, and the friction roller of the lever, L, bears upon the bar, I, and consequently keeps the saw to its work. The reciprocating motion of the

saw is produced by means of the revolution of the crank arm, E, the sleeve, G, working back and forth on the bar, H.

In order to saw down standing trees, the bar, H, is withdrawn from the socket, N, turned, and replaced in the socket. In this case the bar, I, and saw, J, rest upon the bar, H fig. 2, but the friction roller of the lever, L, still bears against the bar, I, and keeps the saw to its work, the saw, of course, cutting in a horizontal direction. The outer end of the bar, H, is clamped to the side of the tree, P.

In order to re-saw the wood into short lengths, another bar, Q, and saw may be attached to the sleeve, G, as in fig. 1, the bar, Q, working in a suitable guide, S, attached to the framing. The lengths of wood represented by T, while being sawed, may rest in suitable hooks, U, at the front of the framing.

This machine is simple, and easily constructed.

More information may be obtained by letter addressed to the patentee, No. 484 Washington street, Boston, Mass.

LEAVITT'S PORTABLE GRAIN MILL.

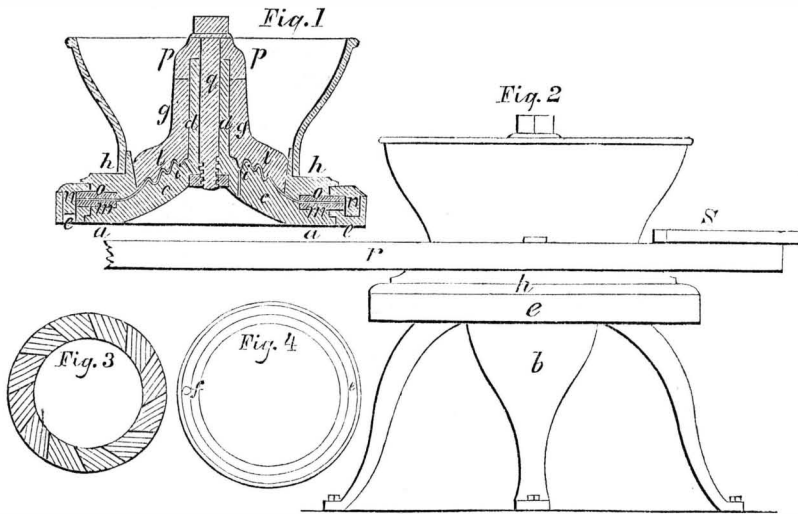

The accompanying figures represent an improved portable grain mill, for which a patent was granted to Charles Leavitt, of the city of Quincy, Ill., on the 27th of last February. Fig. 1 is a vertical section of the mill, fig. 2 is an elevation, fig. 3 is a plan view of the movable rings, and fig. 4 is a plan view of the annular conductor. Similar letters refer to like parts.

The nature of the invention consists in applying to a portable Corn Mill, (in which the external portion or concave revolves upon a fixed cone) the following improvements: First, the combination of the bed plate, legs or supports, the breaker, and the main pivot, cast in one piece. Secondly, in combination with the foregoing, a lever in two parts, attached to an external revolving concave, constructed and arranged substantially as hereinafter described.

The bed plate, a, legs or supports, b, ogee breaker, c, and vertical main pivot, or journal, d, are cast in one piece. Upon a flange projecting from the lower edge of the bed plate, a, is placed an annular grooved conductor, e, which has an outlet at f. Between the top of the breaker, c, and the base of the pivot is an

annular groove, i, with an outlet at the bottom thereof, for the purpose of collecting and discharging the oil from the pivot, d, and preventing it from mixing with the meal. A sleeve, g, fits upon the pivot, d, and revolves thereon, its lower edge resting upon the bottom of the groove, i. A top plate or cover, h, having a circular opening in its center a little less than the base of the breaker, c, is joined to the sleeve, g, by four strong arms, l. The plate, h, extends to the outer edge of the conductor, e, and carries on its under side, square, projecting scrapers, n, which fit in the conductor and revolve therein. The arms, l, are toothed on their under sides to correspond with the teeth in the breaker, c, forming together an effective crusher for the corn and cob when ground together. In the space between the base of the breaker, c, and the inner edge of the conductor, e, are secured by bolts (in such a manner as to be readily removed when required) a flat ring of steel or hardened iron, m, with grinding teeth on its upper side, of any convenient form; but it is preferable for crushing or coarse grinding, to use teeth, the transverse section of which pre-

sents one side inclined and the other vertical. The mill is run in such a direction that the vertical sides of the upper and lower grinding surfaces shall meet each other. In a groove in the upper plate, h, is placed another ring, o, of the same size, material, and form as m, with the teeth of the same form, and arranged as before described; this is also removed when required. Between the ring, o, and the central opening, is a circle of large teeth inclined to the rear, and vertical to the front, and bevelled upwards on their inner edges for the purpose of forcing or crowding the grain on to the rings. It is preferable in grinding fine meal to run the grinding surfaces in such a direction as to oppose the inclined sides of the teeth in one ring to the inclined sides of the teeth of the other; and with that view another pair of rings are made to fit in the same places as the others, with the inclined sides of the teeth reversed.—Upon the top of the pivot, d, is a cap, p, which rests on the sleeve, g. Through the cap, pivot, and bed plate, a screw, q, passes, having its nut at the bottom; the object of this screw is to regulate the mill by pressing the grinding surfaces together. Upon a flange on the edge of the central opening is a suitable hopper. Upon each side of the hopper, resting upon the top plate, h, and secured thereto by bolts, is placed a piece of scantling extending to about twelve feet from the center of the mill, they there meet at a very acute angle, forming a lever secured to a bolt by which the horses are attached. A board, s, extends from one of the ends of the scantling to the other, upon which a man can stand to feed the mill.

This mill is best adapted for crushing and grinding corn and cob together, or by using the rings which present the inclined sides of their teeth to one another for fine meal, &c. If the teeth should wear out or break, fresh rings can be put in at a trifling expense. The annular conductor is a good improvement upon mills of this description, which allow the meal to fall from all parts of the base of the concave. More information may be obtained by letter addressed to the patentee at his residence in Illinois.



Scientific American.

NEW-YORK, SEPTEMBER 8, 1855.

The End of our Year.

With this number we close the tenth volume of the SCIENTIFIC AMERICAN, and drop the curtain upon the professional labors of an entire year. To one and all of many thousands of kind readers and friends, we return our sincere thanks for the aid they have lent us in sustaining our work during the past, and for the encouragement they have so nobly proffered, to increase our efforts in the future. They may rest assured that nothing within the reach of our humble capacities will be spared in order that we may merit the continuance of their generous patronage and approbation.

Set out in the size and form of an ordinary book, the contents of our last year's volume would cover hardly less than two thousand pages, with near five hundred fresh, original engravings. No expense or pains have been omitted to render our work, in a measure, complete in all its divisions. The world of discovery and knowledge has been watched and ransacked, and its various departments made to contribute, in some degree, to the wants and interests of the great family of minds within our care.

In compensation for these outlays and labors we have levied a tax upon our subscribers of two-thirds of a cent per diem from each,—the sum they pay for our paper at the subscription price of \$2 a year. When we reflect that the ordinary cost of a good Encyclopædia is seldom less than ten dollars, and that such a work touches not a tithe of the subjects which come within the range of a single volume of the SCIENTIFIC AMERICAN, we think none of our readers will be apt to regard the levy we make as very extravagant. On the contrary, they cannot fail to be impressed with the extraordinary cheapness of our publication, while they feel that its circulation ought to be extended to the highest possible degree. We ask, this year, that each of our subscribers will act under the impulse of such thoughts; that he will use a little personal exertion to increase the number of subscribers to our work; that he will endeavor, for once, to gladden our hearts, and also contribute his mite towards the spread of sound and useful information, by endeavoring to send us at least one new name, with his own, on the renewal of his subscription.

More About Lightning and its Conductors.

Lightning rods do not attract electricity, nor is that their object; they are simple conductors of the electric fluid, and are erected higher than the other parts of buildings so as to act as highways for the fluid from the cloud to the earth.

The great number of houses, towers, and ships without rods that have been struck with lightning, afford evidence that it always selects the nearest object from a surcharged cloud to reach the earth. With respect to lightning and its action, Sir Snow Harris, who has perhaps written most ably on the subject, says: "lightning is the evidence of some occult power of nature forcing a path through substances which offer greater or less resistance to its progress, such as atmospheric air, vitreous and dry vegetable substances, and the like. In the case of such bodies, a powerful evolution of light and heat attends its course, together with an irresistible and disruptive force, by which compact substances are rent asunder, whereas it finds an easy path through some substances which offer but little resistance, such as copper, iron, &c." By good metallic conductors, then, lightning becomes transformed into an unseen harmless current, hence the great benefit of and necessity for the use of such protectives in all countries subject to severe thunder storms. A lightning rod, to be effective, must be of such a capacity as to conduct all the electric current unseen to the earth, for if too small it may be fused, and the current will discharge itself through other parts of a building. It must always be continuous, and terminate in some moist part of the earth, to conduct it away and dissipate it in the mass below. The larger the electric conductor, the better, for it possesses the greater capacity to conduct the current with safety and ease. If the bed of a stream is too narrow to allow the passage of

accumulated waters, they overflow its banks and carry destruction in their course, but if its banks are high and spacious they confine the water, and protect the surrounding vales; it is the same with electric conductors. If all houses were built of metal, such as cast iron, they would be perfectly free from danger by lightning, as great masses of conducting material obviate all danger. We have seen many lightning conductors put up too small to be of any great value, and others erected displaying equal ignorance of the nature of lightning.—Thus, some rods are made to terminate in a dry sandy soil and others in ground which becomes hard, dry, and caked in summer.—The effect of such methods of terminating the conducting rods is like raising a dam to obstruct the progress of a swollen river. Conductors shall always terminate in moist earth, or in water.

For the central tower, 150 feet above the roof of the new House of Parliament in London, Sir Snow Harris recommends a capacious conductor of a copper tube two inches in diameter and one-eighth of an inch thick, and conducted to the earth in as straight a direction as possible, and also connected to all other metal tubing in the building, for the purpose of spreading the electric current through numerous channels, and thus weaken its force.

Sheet copper for conductors 5 inches wide and 3-8ths thick, is sold at 31 1-2 cents per foot. Such strips of copper have proven to be safe conductors for ships, and they will make most beautiful ones for houses. As conductors require to be large—possess mass—according to their length, those for houses need not be so broad as those for ships. Such copper sheets cut into ribbons 2 1-2 inches wide, would embrace a solid capacity of nearly half a cubic inch of metal, costing not quite 16 cents per foot. How easily these can be laid along the crowns of roofs, and up the sides of gables and chimneys. It would be well to have a point extending above every chimney in a house, and all of them perfectly connected to the copper strips, and the latter terminating by a suitable rod in the earth. Copper is eight times a better conductor than iron, and not so subject to oxydation.

We have lately seen lightning conductors composed of copper and iron wires, twisted together and connected at the foot in the ground with a cylinder of zinc. The object of this combination is to prevent—as we have been assured it would—the iron being coated with an oxyd, which impairs its conducting qualities. Sir Humphrey Davy noticed that substances would only combine chemically when in different electrical states, and that by bringing a body naturally positive into an artificially negative state, its usual powers of combination were destroyed. Copper is a metal but slightly positive, and by bringing it in contact with another, to render it slightly negative, the decomposing action of moisture and air are rendered null. He therefore attached a piece of zinc about an inch square to a plate of copper, and immersed it in sea water, and the result was that the zinc preserved fifty square inches of the copper from corrosion. An iron nail secured to the copper plate produced the same results. The copper was preserved, but the iron and zinc slowly corroded. If a cheap lightning conductor, composed of iron and copper wire, can be preserved from corrosion by a small zinc cylinder in the ground—which can be renewed often at but little expense—then an object of some importance is accomplished, but this is a question which only relates to the preservation from oxydation of the conductors.

Statistics of the New York and Erie Railroad for July.

We are indebted to the General Superintendent, D. C. McCallum, Esq., for statistics of the work done and expenses of all the divisions of the above railroad during the month of July last. These are embraced in tables, showing the amount of miles run by each engine (with its number pointed out,) the load carried, and the whole expenses for fuel, oil, tallow, waste, repairs, wages, &c. The number of miles run on the whole lines, 249,470; the cost for engines and firemen was \$13,185,67, (5 29-100 cts. per mile;) the miles run to one pint of oil, 15 53-100; the cost per mile for waste, tallow, and oil, 1 31-100 cents; the cost for repairs of

engines per mile, 5 72-100; the cost of fuel (wood) per mile, 11 12-100 cents—31 38-100 miles run with one cord. The total cost, \$58,469,92 (23 44-100 cents per mile.) These tables are prepared for the benefit of the employees, and since the commencement of their publication, there has been a considerable reduction of expenses. In the month of May, the total cost per mile was 25 49-100 cents; in June, 24 30-100; in July, 23 44-100—amounting to 2 05-100 per mile, thus saving more than the expense for oil, waste, and tallow. The greatest constant expense for any one item is that of fuel, it amounts to more than double the expense for repairs of engines. Improvements for reducing the cost by the use of coal, or some other means are much wanted.

Alarming Encroachment on the Patent Office.

An esteemed correspondent, resident in Washington, informs us that the Secretary of the Interior has just issued a command directing the immediate surrender of one entire floor of the new Patent Office building, to the uses of the Indian Department. In less than a week's time, he presumes that an army of scribbling clerks, will occupy the noble halls, which wise statesmen of former days, had set aside and consecrated to the promotion of American genius.

We can regard this action as little better than an official outrage, which, if left to reach a full consummation, will result in evils of a very serious nature. It is, we fear, but the beginning of a sad retrogression in the affairs of the Patent Office, consequent upon the want of a vigorous and determined chief.

When the Hon. Charles Mason occupied the Commissionership, he resisted, successfully, all such attempts to abridge the usefulness of the Patent Office. He saw how the interests of inventors had suffered—and through them the whole country—by reason of the crowded and pinched space then allowed. Models had to be heaped up in promiscuous piles, never to be got at when wanted. Drawings and matters for immediate reference were deposited, some in one room and some in another. Every thing was confused and inconvenient, to such a degree, that labors which are now done promptly in an hour's time, were then dragged along for days and weeks, nay even months. Our readers are familiar with the history of his reformatory operations; they know how he gradually rescued the department from its deplorable condition, infused new life apparently into the entire patent system, put an end to those deadly delays in the issue of patents which had so long disheartened inventors, increased the business and revenues, and then, to the regret of all,—left office.

No sooner is his back turned than the insidious efforts of politicians are put to work, again to undermine and cripple the efficiency of this noble branch of the public service. Unless something is soon done to arrest the new encroachment, inventors may expect, ere long, to be compelled to await the action of the government upon their patent cases by the year, instead of by the week, as at present.

The Secretary of the Interior will add nothing to his reputation for sagacity and statesmanship by this uncalled-for thrust into the vitals of the Patent Office. Instead of retarding and reducing the Department, it should be his highest study to promote its convenience and extend the sphere of its usefulness. We are surprised that he should regard the personal comfort of his Indian clerks, as superior, in importance, to the free and unrestrained operation of the United States Patent Office—that glorious institution through whose instrumentality the long catalogue of splendid inventions and discoveries, which now help to prosper our country and give her a name throughout the world, have been called into existence.

Shocking Railroad Accident.

A most lamentable railroad accident occurred on the Camden and Amboy Railroad, N. J., on the 29th ult. by which three passenger cars were smashed to atoms, twenty of the passengers killed, and seventy wounded.

The 10 o'clock train from Philadelphia had arrived at Burlington on its way to New York, somewhat behind its usual time, and was obliged to wait there ten minutes for the 8 o'clock train from New York, which was also behind time. Having waited the required time

it moved cautiously on its way for about three miles, when it was discovered that the New York train had arrived first at the half-way post, and was, by the rules of the road, entitled to the track. It then backed at the rate of twenty miles per hour, when it came into collision, on a crossing, with the horses attached to the light pleasure wagon of a Dr. Heineken, about half a mile from Burlington. The horses were killed instantaneously, one being thrown forty yards from the track.

The scene was horrible. The cars were piled upon each other, and numbers of human beings were lying among the ruins—some dead, some dying, some shrieking from pain. Those saved in the train, and the passengers on the down train, aided by citizens of Burlington, who were quickly informed of the terrible accident, went to work to rescue the wounded and dying from the ruins. As soon as taken out they were conveyed to Burlington, where many private houses were thrown open to the admission of the wounded. The coroner's jury has been employed since in investigating the causes of this terrible catastrophe. These appear to be transparent; the fault lies entirely, we think, with the managers of the railroad. If the road had a double track, the accident would not have taken place. For years we have advocated double tracks, well fenced in, with gates at all the crossings. If such improvements were made on all our railroads, no collisions would ever take place. There is less excuse for this old, wealthy railroad corporation not having these improvements, than any other in our country.

Van Amringe's Fire Ladder.

A trial of Van Amringe's Fire Ladder was made at Cincinnati a few days since, with complete success. The machine is mounted upon wheels, and the ladder proper consists of four spars, forty-five feet long, each springing from a corner of the bed, which is ten feet by fifteen. When not in use, the spars are lowered past each other, and rest upon supports at each end of the bed, so that one pair projects over the horses, and the other "astern." The affair looked heavy and cumbersome, but upon its arrival upon the ground it was erected, by means of a rope attached to the top of one pair of spars, and run over a sheave on the other to a windlass on the bed, in forty-five seconds. Several lines of hose had been attached to the gallery previous to erection, and before the horses were unhitched four men were upon the highest gallery, fifty feet from the ground, and coupling their hose pipes. It was afterwards drawn along the street with five men in the highest gallery, and six men in the lower ones, of which there are four, corresponding in height with windows in different stories of houses.

Altogether, it is a plain, common sense invention, which relieves firemen from the dangerous duty of clambering over slippery roofs, blinded by smoke and glare, and in constant dread of falling walls and roofs, while the force required to work it effectually is but four men and two horses. Measures have been taken to secure a patent.

INVENTIVE ACTIVITY—111 applications for home and foreign patents were made through the Scientific American Agency last month.

SPLENDID CASH PRIZES!

The proprietors of the SCIENTIFIC AMERICAN will pay in cash the following splendid prizes for the fourteen largest list of subscribers sent in between the present time and the 1st of January, 1856; to wit:

|                           |       |
|---------------------------|-------|
| For the largest List      | \$100 |
| For the 2d largest List   | 75    |
| For the 3d largest List   | 65    |
| For the 4th largest List  | 55    |
| For the 5th largest List  | 50    |
| For the 6th largest List  | 45    |
| For the 7th largest List  | 40    |
| For the 8th largest List  | 35    |
| For the 9th largest List  | 30    |
| For the 10th largest List | 25    |
| For the 11th largest List | 20    |
| For the 12th largest List | 15    |
| For the 13th largest List | 10    |
| For the 14th largest List | 5     |

Names can be sent in at different times, and from different Post Offices. The cash will be paid to the order of the successful competitor immediately after the 1st of January, 1856.—Southern, Western, and Canada money taken for subscriptions. Post-pay all letters, and direct to

MUNN & CO 128 Fulton st., New York.  
See prospectus on the last page.



[Reported Officially for the Scientific American.]  
**LIST OF PATENT CLAIMS**  
 Issued from the United States Patent Office,  
 FOR THE WEEK ENDING AUG. 28, 1855.

**TRAPS FOR CATCHING ANIMALS.**—J. B. Bradley, of Watertown, Ct. : I claim the application of the ratchet bar, I, and pawl, J, to the trap, for the purpose of rendering it capable of confining the animal, after being caught under the drop or fall, as set forth.

[This patent is for an improvement on the rat trap patented by Mr. Bradley in May last, and noticed by us at that time. The present invention consists of a slight but ingenious addition, which renders the apparatus perfectly effective for the catching of wolves, foxes, woodchucks, and other species of game. We do not know of a cheaper or better trap for the purposes named than the above.—When set, it lays "as flat as a board," so that the whole concern except the bait may be covered up in the sand entirely out of sight. Many a wary fox whose superior cunning had hitherto enabled him, on all occasions, to outwit his old enemy, man, has since ascertained by the sudden forfeit of his life, that the inventor of this contrivance is a step or two in advance of his neighbors in the way of ingenuity. Reynard is at last come up with. This is a good patent, and so is the other to which we have alluded. Both will be serviceable to the country, for they are wanted every where.]

**COTTON GIN SAWS.**—A. D. Brown, of Columbus, Ga., assignor to Margaret L. Brown, of Opelika, Ala. : I am aware that cotton gin saws have previously been constructed in segments of circles, but I regard that as a totally different arrangement, as the teeth are arranged in the same circle, and I do not claim any such arrangement. But I claim arranging the teeth in a series of curves, b, b, eccentric to the axis of the saws, or what is equivalent, in a series of tangential lines, substantially as set forth.

[This invention consists in arranging the teeth of the saws in a series of curves eccentric to their axis, or, what is equivalent, in a series of tangential lines. By this means, with a proper arrangement of the saws relatively to each other, it is rendered impossible for any two saws to catch the same fiber across a rib, and thereby cut or break it, while a peculiar degree of facility is provided for the clearing of the saws by the brush. It is one of the most ingenious and excellent improvements in its class that we have seen for a long time. Its general introduction will tend to improve the value of our cotton staple. No one can fail to see that cotton, which comes to the manufacturer with its fibers evenly preserved to their natural length, is worth considerably more to him than where it is all broken and cut up. The expense of gins made according to this patent is no greater than those in ordinary use, while, as we have shown, the cotton comes out equally as well cleaned, and otherwise in a far superior state. The amount of work done is also the same as in other gins of like capacity. These striking facts cannot fail to bring Mr. Brown's invention to the notice of planters and others. The improvement seems destined to take a high rank among the improved labor-saving machines of the day. The patent we regard as one of importance and value.]

**SPLITTING FIREWOOD.**—W. O. Bisbee, of Camden, N. J. : I wish it to be distinctly understood that I do not wish to confine myself to the exact form or method described, of operating the machine, or to the exact number of vertical knives shown.

But I claim the vertical knives, G, as arranged, with their edges a distance in advance of each other, and their sides at different angles, so as to act effectively as a means of rifling wood, as described.

**PREPARATIONS OF WOOL OIL.**—Thos. Barrows, of Dedham, Mass. : In basing my claim of invention or improvement, on the use of mucilaginous matter, I do not include aluminous or gelatinous matter of animal origin, nor ammonia or other alkaline emulsions which have been before used; but restrict myself to the use of those watery solutions of mucilage from plants and seeds, where muculent character is distinguished from the gum or glue-like character of those substances heretofore used, by not drying out from the mixture with the oil, when on the fibers of the wool I use the oils, adapted to oiling wool, in mixture with mucilage, although such mixture, by rest, for a longer or a shorter time, will become separated into oil, which floats, and mucilage which subsides; but prefer the prepared oleic acid or olein mixture, as it often remains uniform several days. I, however, lay no claim to the application of oleic acid, as described.

But I claim, for the treatment and imbuing of wool, during or previous to its manufacture into yarn or cloth, the application thereto, of mucilage, possessing an attraction for water, such being found in sea mosses and allied vegetable productions, or in various seeds, such as flax seed, it being used either alone or in mixture with an oil, or some other material.

**CARRIAGES.**—J. L. Cisco, of Xenia, O. : I claim the application of the apparatus described, in turning carriages short, consisting of the half circle bars or plates, and sliding bar attached to the running gear, as described, in connection with the fifth wheels, by which, in turning short, the body is carried out of the way of the wheels, in manner substantially as described, or any other apparatus, substantially the same, producing the same effect.

**FACILITATING THE REMOVAL OF INCrustATION FROM STEAM BOILERS.**—P. Dimpfel, of Philadelphia, Pa. : I claim the method substantially as described, of facilitating the removal of incrustation in steam boilers, by inducing breaks in the circle of the incrustation, in the manner described.

**HARVESTER RAKES.**—O. C. Green, of Belleville, Ill. : I am aware that the delivery of grain at right angles to the line of draft of the team, has been accomplished by means of a rake travelling across the platform, in conjunction with a second rake, turning in a segment of a circle, and therefore I do not claim the described delivery of grain, irrespective of the means by which it is accomplished.

But I claim in rakes to harvesters, the combination of the rake, I, sliding head, G, way or guide, b, fender board, L, and incline plane, M, or severally of their equivalents, operating in the manner and for the purpose set forth, so that with a single rake I accomplish the raking of grain across the platform, and the delivery thereof, in the manner substantially as set forth.

**SASH FASTENERS.**—Asahel Gilbert, Jr., of Lowell, Mass. : I claim the hinged cross bars, c, c, having split knob handles, serving to disengage the fastening in both sides of the sash, and to raise and lower the sash.

**ROTARY WOOD SPLITTING MACHINE.**—G. W. B. Gedney, of New York City : I claim the machine described for splitting wood, consisting of the V-grooved knives, acting upon the wood as described, having openings in their apex to receive the cleavers, substantially as specified, and in combination therewith the fingers for holding down the rear end of the wood to be split.

I also claim the mode of attaching the knives by the groove, e, at their back, and an over-reaching flange e<sub>2</sub>, by which the resisting strain tends to hold the knife in place, as specified, without bringing the strain upon the bolt, by which it is fastened.

**VISE.**—Robt. W. and Daniel Davis, of Yellow Springs, Ohio : We are aware that parallel vises have been heretofore constructed with cross levers and ratchet movement, and do not claim merely such as our invention. But we claim our improved arrangement of the sliding ratchet beam, C, pawl, M, and the detachable weighted key, P, and the cam, E, all constructed and operated substantially as described.

[In the construction of this vise the movable jaw is furnished, near its base, with a guide piece, which passes through a slot in the fixed jaw; the latter also as a guide, which passes through the movable jaw. Between, and attached to these guide-pieces are a pair of cross levers, or connecting rods, so pivoted and arranged that when the screw which operates the vise is turned, the movable jaw will always retain a position exactly perpendicular to that of the fixed jaw. All mechanics know the importance of keeping the two jaws thus in agreement. It allows a firmer hold to be taken on any substance placed between, relieves the screw of friction, and prevents the tendency of the vise to become weakened or soon to wear out. There are several different kinds of vises arranged with a view to accomplish the above purposes. The invention of the Messrs. Davis is intended to be considerably cheaper in construction, and, if possible, more effective in its operations than any of them. Only one screw is employed, and no nut is required to be sunk in the movable jaw. In other ways, also, the construction is cheapened. We regard the invention as a very excellent one.]

**Plows.**—J. L. Gill, of Columbus, O. : I am aware that a combined steel and cast-iron mold board has been used; and also, that a cast standard has been used; these I do not claim. Neither do I claim any of the parts used, separately; but I claim a plow composed of a steel mold-board, cast-iron share, shaft, and landside, when the several parts are arranged as set forth.

**LIME KILNS.**—Danl. Herr Pequea, of Lancaster, Pa. : I claim making the arch of kiln, with two series of arch-chambered ribs, so arranged that the outer ribs shall extend over and across the spaces left between the inner ribs, and at the same time leave sufficient space between the out and inner ribs, for the fire and heat to pass into the lime stone, whereby the fragments and loose lime are all prevented from falling into the fire, and are conducted down the channels into the proper receptacle below.

**HAND STAMP.**—Horace Holt, of Winchester, Mass. : I claim a hand stamp in which the stamp is inked, and the impression effected by the movement of the stamp in one vertical plane, the ink being arranged directly under the stamp, and provided with a cover which can be moved away from or upon the said pan, or fountain, that by sewing, both as a cover to the ink receptacle, and as a platen to the article to be printed.

**SCYTHES FASTENING.**—B. F. Joselyn, of Worcester, Mass. : I claim in the arrangement of the lever, D, as applied to a hoop, e, as set forth, as a means of securing the shank of the scythe, to the end of the snath.

**WEIGHING SCALES.**—J. L. McPherson, of New Vienna, Ohio : I am aware that various things have been made tubular, or hollow, for the purposes of strength with lightness of metal. This I do not claim.

But I claim, in combination with the shafts, H, the fifth or guard fulcrum, c, which prevents the platform from careening, should the weight be unequally distributed on said platform, without in the least impairing its correct weighing, as set forth.

**REGULATING VALVE FOR STEAM ENGINES.**—E. G. Russell, of Ravenna, O. : I do not claim to be the first inventor of a regulating valve, the area of whose opening is increased or diminished by any tendency of increased or diminished velocity.

But I claim the hollow cylindrical valve, D, open at one end and closed at the other, fitted in a cylindrical seat with its closed end on the inlet side of the said seat, and provided with a slot at one side, near the closed end, to allow the steam to pass through its interior, and having a spring applied, to balance the excess of pressure on the inlet side, and to give a tendency to open the valve, the whole operating as described.

[Cut-off valves for steam engines, arranged so as to be self-acting, and thus in a measure to serve as governors, have long been known. They are generally made to operate by means of a spring, so placed as to press open the valve with a given degree of strength; but when the pressure of the steam is greater than that of the valve the latter closes. It is obvious that such valves, if they could always be made to work with efficiency and certainty, would be very valuable auxiliaries to the steam engine; since they would tend greatly to simplify the mechanism and cheapen the cost. Mr. Russell's improvement consists in a peculiar form and arrangement of the valve and spring, whereby the difficulties which have hitherto attended the operation of self-acting steam valves generally, are believed to have been entirely overcome. The improved parts are pretty clearly set forth in the claims. The invention is one of ingenuity and importance. We commend it to the attention of all engineers.]

**SEWING MACHINE CASES.**—F. A. Ross & Wm. H. Marshall, of New York City : We claim the making the case in the form of a cabinet, which, when opened, will afford space for operating the machine by the treadles, and will form a table for the work, by raising the leaves and supporting them by the doors of the cabinet, when thrown open in the manner described.

We also claim the construction of the folding top, which when open, furnishes drawers and shelf, for the convenience of the operator, as described.

**SHUTTERS OR BLINDS FOR STORES.**—David Rohan, of Cincinnati, Ohio : I claim hinging the shutters together, by mitered joints, so that when closed the joint or hinges may be concealed.

I also claim, in connection with the mitered shutters, B, C, the hinged piece, G, which serves the double purpose of a post, against which said shutters abut, and to which they may be locked, when the front is closed, and also as a finish to one of the shutters, when it is run back, as represented.

**TRIMMING BOOKS.**—M. Riehl, of Cincinnati, O. : I claim hanging or attaching the knife, H, to the cross-piece, B, of the uprights, A, A, by the arms, a, a, as shown, whereby a drawing or oblique cut of the knife, is obtained, and operating the knife, by means of the worm wheel, E, screw, F, and connecting bar, D.

[Few substances are more difficult to cut, with a smooth, true edge, than sheets of paper, laid together in quantities. Printers and bookbinders have always experienced the truth of the fact, although many an inventor has studied hard to relieve their troubles from this cause. Complete success, however, has never been reached. Many ingenious devices have been made, but nearly all of them fall short of the mark, in one way or another. Mr. Riehl claims a priority of excellence in the device now patented. The sheets of paper to be severed are laid on a table; the knife is attached to a crank arrangement and pitman, in such a manner that by turning the crank the knife edge is forcibly drawn across the paper and the cutting thus effected. This drawing movement of the knife is the peculiar feature. For the purposes intended it is certainly an admirable arrangement. The invention is simple cheap in construction and effective.]

**BREACH-LOADING FIRE ARMS.**—B. F. Joselyn, of Worcester, Mass. : I claim the combining of the cone-headed pin, I, and two or more expanding rings, G and H, with the radial breach, C, of breach-loading fire arms.

**GRAIN AND GRASS HARVESTERS.**—Jno. Thompson, of Clifton, N. Y. : I claim discharging the grain from the platform, between the platform and the driving wheel and under its axle, when the same is done, in connection with a pair of wheels, whose axle extends across the machine, as described.

**BRICK MACHINES.**—Levi Till, of Sandusky, Ohio : I claim, first, the use of the air pump, in combination with the perforated pressers, by which the air is exhausted from the clay, while under pressure, as stated, and not otherwise.

Second, I claim the device of the diagonal slots, m fig. 3, in combination with alternating with the pressers, by which all the excess of clay may escape, and is discharged on one side, and not on both, of the machine.

**WAGONS.**—James Parsons, of Dublin, Ind. : First, I claim the arrangement of the side pieces or ways, A, A, resting upon the elevating blocks, n, n, near the outer end of the bolster, C, thereby gaining a greater width between them than is attained in other wagons constructed for similar purposes, thus giving space for loading, if raised on a plank or platform, to raise partly above and between them, if necessary to clear the ground, in hauling; also the manner of their connection between the forward and hind wheels by passing or sliding through the brace bands, e, e, of the mortises or slots, o, o, of the arch.

Second, I claim the structure of cast arch, the open mortises or slots, and their uses, that when the arch, P, H, and wrought axletree combined, as represented in fig. 2, when supported by the hind wheels, the mortises or slots, o, o, will be brought nearly or quite in a horizontal position, for the reception of the side pieces or ways, as described, thus serving the purposes of coupling the wagon, long or short, to suit circumstances.

Third, I also claim the peculiar adaptation of the oblong, e, e, of the braces, H, H, through the side pieces or ways, slide, and the hind elevating blocks pass, and the blocks being held in their proper position, by the bands, e, e, dropping into the notches, ff, of elevating blocks, D, D, thus giving them the sliding motion upon the side pieces or ways, and the side pieces or ways are permitted to slide forward or backward, and under the blocks, and from them they form a connection with the cast arch and wrought axletree, by a stirrup firmly binding them together.

Fourth, I also claim the manner of so arranging the hind elevating blocks, D, D, as to give them the sliding principle, as described, and the ears, s, s, on opposite sides, thus rendering them adjustable, in coupling the wagon, long or short, by means of the steady or toggle pins, i, i, i, and again by the holding in connection with the braces, the arch in a perpendicular position, by the upper part of the casting, or mortises or slots, o, o, being notched into the elevating blocks, as at c, c, as described and shown.

**CHANGING HARVESTERS FROM REAPERS TO MOWERS.**—Robt. Beans, of Johnsonville, Pa. : I claim the combination of the lever, O, and connecting rod, P, with any means of altering the height of the frame, above the cutter bar, for the purpose of retaining the same relations between the stroke of the knives and the teeth or fingers, although the distance between the head of the cutter bar and the crank, be varied in so doing, as set forth.

**CUTTING STANDING COTTON STALKS.**—S. Bowerman, of Detroit, Mich. : I claim the combination of the block, F, knife, G, rods, H, H, springs, I, I, rack, X, and cog wheel, J, when arranged for the purposes specified and shown.

[In the Southern latitudes of this country, where cotton is extensively grown, the removal of the stalks prior to the preparation of the land for new planting, is a slow and laborious operation, for it is usually done by hand.—The negro seizes hold of the stalk and bends it with one hand, while with the other he cuts it off at the root by means of a heavy cleaver.

Mr. Bowerman's invention consists of a cart which is driven through the stalks in order to bend them down close to the ground. At the rear part of the vehicle a large horizontal knife is arranged to move vertically between suitable slides. Motion is given to the knife by means of gearing on the wheels of the vehicle. As the cart advances the stalks bend, the knife is elevated and then suddenly discharged, to fall upon the base of the bent stalks, and clip them in a twinkling. Springs are employed to give additional force to the knife as it descends. Every one will see at a glance how much superior this mechanism is to hand labor.]

**SHIPS WINDLASSES.**—James Emerson, of Worcester, Mass. : I claim the gearing, C, D, L, M, and the ratchet, N, and O, on the shaft, I, when arranged substantially as shown, for the purpose of operating the shaft, I, of the windlass, with a quick or slower, or vibrating motion, and with a corresponding degree of power; one set of gear wheels, C, L, being independent of the other set, D, M, and allowing the windlass, in case of the breaking of one, to be operated by the other.

[The above is a highly valuable improvement. Without increasing the cost of the windlass, it affords much greater power, is more convenient, stronger, and less likely to get out of order than almost any of the other patented improvements of its class. We have in preparation some engravings illustrative of this invention, which will shortly be published, when the good qualities of the invention will be made to speak for themselves. Foreign patents have been taken out through the Scientific American Patent Agency.]

**CUTTING IRREGULAR FORMS.**—P. H. Wait, of Barkersville, N. Y. : I do not claim the pattern, H, or the means of turning irregular formed articles by means of a pattern, for this has been previously done in various ways. But I claim the employment or use of two vibrating or oscillating frames, placed upon a rod or shaft, B, and operating by means of the pattern, H, bearing against the sliding rollers or disks, C, C, in pattern, as H rotates, moving the stuff at the upper parts of the frames, towards and from the cutter disk, L, the cutter disk and rollers or disks being moved by means of the screw rod or shaft, G, and nut, F, as shown.

[This is an improvement upon Blanchard's well-known turning lathe—the first automatic machine ever made which was capable of producing an exact copy of an irregular pattern. The frame of Mr. Wait's machine looks somewhat like a saw-horse, for it consists of four arms, crossed and hung on a central shaft. The upper ends of the arms are furnished with revolving cutters, which bear against the stuff to be turned. The lower ends of the arms are made to embrace the pattern between them, being pressed up against it by means of springs. It should be observed that the frame does not revolve, but the arms move on the shaft, which serves as a pivot. When the pattern is made to revolve, the lower ends of the arms follow its irregularities, and thus correspondingly move the cutters to or from the stuff to be turned. There are two sets of cutters, and consequently two copies of the pattern are simultaneously turned.

The chief advantages of this machine over Blanchard's and other lathes for turning irregular forms consist, first, in causing the guide arms or pattern followers to embrace the pattern, so that no matter how long and slender the pattern may be, it can never give way or bend. Second, in producing two copies of the pattern at once; or, in other words, doubling the quantity of work produced without any additional complication of the machine. We might mention other advantages, but the two features named are sufficient to indicate the great importance and value of the invention. That it will find a very extensive introduction we cannot doubt.]

**REAPING AND MOWING MACHINES.**—Henry Waterman, of Williamsburgh, N. Y. : I do not claim the advancing and retreating curvilinear motion of the cutter bar.

But I claim the combination of the two sets of knives described, with the curvilinear motion of the cutter bar. I claim the elastic fingers, in combination with the curvilinear motion of the cutter bar.

I claim collecting and depositing the grain by the revolving cradles, by the weight of the grain laid upon them by the reel.

**INKSTANDS.**—Albert Bingham, (assignor to himself, and Andrew J. Bailey,) of Boston, Mass. : I claim arranging and combining with the hinged cover, G, of the pen-port, B, substantially as described, the bow lever, H, whereby the cover may be raised, under circumstances and in the manner specified.

**COLLAPSIBLE BOAT.**—Nathan Thompson, Jr., of Williamsburgh, N. Y. : Patented in England Feb. 23, 1855; I claim, first, the combination of hinged flaps, or bottom pieces, with elastic or flexible sides, in the manner and for the purpose specified.

Second, the combination of hinged flaps with a center keelson and flexible or elastic sides, as set forth.

Third, I claim either of these combinations in connection with water-proof fabric, for closing and securing the joints between the several parts, applied substantially as specified.

Fourth, I claim a hinged swinging brace in combination with a hinged thwart thereto attached.

Lastly, I claim the sliding joint, in combination with the bow and stern hinges, whereby the effective length of a keelson or flaps, may be altered so as to suit the expanded and collapsed states of the boat.

**STRAW CUTTERS.**—J. A. Thompson, of Cayuga, N. Y. : I claim giving the cutting disk of a straw cutter, a combined rotary and reciprocating motion, in the manner set forth.

**FLASK FOR MOLDING BATH TUBS.**—Jno. Demarest, assignor to "the J. L. Mott Iron Works," of Mott Haven, N. Y. : I claim connection, by means of a brace or braces, the sides of the drag or first section, and of the cope or third section of flasks, for casting bath tubs or other large and thin hollow vessels, substantially as described, in combination with the clamps and adjusting screws, or their equivalents, which embrace and act upon the sides of the cheek or second section of the flask.

And I also claim recessing the upper edge of the wings on the inside of the cheek, or second section of the flask, back of the inner edge, as specified.

**VAULT LIGHTS.**—Wm. P. Walter and Jacob Green, of Philadelphia, Pa. : We are aware that it is a very common device to avail one's self of the expansive and contracting properties of metal, in fitting metal rings tightly around various articles; and we are also aware that it is not a new device to unite silicious compounds to metal by casting the former in a molten state about the latter, as, for instance, in the manufacture of porcelain or glass door knobs, with metal shanks; we therefore disclaim both of these as broad devices.

But we claim the described improvement in the construction of vault lights, viz., casting the molten glass directly into the metal frame, while in a heated state, said metal frame being grooved internally, so that when it contracts on cooling, and contracting as it does, more than the glass, this groove shall bind the glass lens tightly in its place and so retain it.

RE-ISSUES.

**HINGES.**—Chas. Parker, of Meriden, Ct., assignee of Wm. Baker, of Utica, N. Y. : Originally patented April 13, 1832; I do not claim as new, simply constructing the window blind hinge, with its screw plate so arranged as to be screwed to the back of the blind, and the outside of the window-casing.

But I claim the bridge, or inclined plane, at the base of the blind, and the corresponding corresponding operation, raising, and in connection with the hook and catch, attached and connected in the manner described.

I also claim the elongated or enlarged eye, independently of its combination with the bridge, for giving the lateral motion to the blind, to effect the disengagement of the lower catch, as described.

I also claim, so placing the catches on the two parts of the hinge, as to cause the strains produced by the wire, otherwise, to act directly upon the screws, whereby the pin and eye are relieved, as described.

DESIGNS.

**STOVES AND FIRE PLACES.**—Winslow Ames, of Nashua, N. H.

**COOKING STOVES.**—Russell Wheeler and Stephen A. Bailey, of Utica, N. Y.

**PORTABLE FIRE PLACES.**—Winslow Ames, of Nashua, N. H.

**COOKING STOVES.**—Conrad Harris, and Paul Wm. Joiner, of Cincinnati, O., assignors to A. Bradley, of Pittsburgh, Pa.

Great Trial of Agricultural Machines in France. America Victorious.

On the 14th of last month the great finishing trial of agricultural implements and machines on exhibition at Paris took place before the Grand Jury on the farm of the Postmaster General, M. Dailly, at La Trappes. Almost all the great men of France were present, as were many eminent Americans—ex-President Fillmore among the number—Germans, and British. The fields were smooth and beautiful, and the experiments consisted of drainage machines, plows, thrashers, sowing machines, reapers and mowers.

Hundreds of machines were tested, and for the minor ones, the English carried off two-thirds of the honors; but the great interest was riveted on the reapers and thrashers. The contest with the former was among the Americans; they had the whole field to themselves. Manny's, Wright's (Adkin's Automaton Raker), Hussey's and McCormick's reapers, were tested together, and the latter came off the victor. From the description given of the trial, much seems to be due to the able management of McKenzie, the agent of McCormick: Four thrashing machines were tried, and six men with flails, to test the difference of the labor. Pitt's American thrasher "bore the bell" among them all. The six men thrashed 60 litres of wheat in thirty minutes, Pitt's machine 740 litres, the English machine 410, the French machine, 250, the Belgian machine 150. In these trials of reaping and thrashing machines America stood singularly pre-eminent, and the effect upon the thousands who witnessed their operations was most happy. The practical and useful character of our inventions is now highly appreciated by the most distinguished men in Europe.

Submarine Telegraph Cable Lost.

News has been received by telegraph in this city, that the submarine cable for connecting Newfoundland with Cape Breton by telegraph was lost by some mismanagement "when forty miles out." The intelligence is indefinite as to the cause of the loss. It was seventy miles long, and made in England. We hope it can be "fished up," as its entire loss will prevent the completion of the telegraph line to Newfoundland, for at least another year.



Important Items.

BACK NUMBERS AND VOLUMES—We have the following numbers and volumes of the SCIENTIFIC AMERICAN, which we can supply at the annexed prices.—Of Vol. 10, all except Nos. 17, 25, 26, 27, 28, 29, 30, 40, 41, and at the subscription price. Complete Volumes will be ready for delivery in about two weeks. Price \$2.75 bound; \$2 in sheets.

MODELS—We are receiving almost daily, models of inventions which have not the names of their inventors marked upon them. This usually prevents us from taking any notice of them whatever. We shall esteem it a great favor if inventors will always attach their names to such models as they send us. It will save us much trouble, and sometimes prevent the model from being mislaid.

RECEIPTS—When money is paid at the office for subscription, a receipt for it will always be given; but when subscribers remit their money by mail, they may consider the arrival of the first paper a bona fide acknowledgment of the receipt of their funds.

Give INTELLIGIBLE DIRECTIONS—We often receive letters with money enclosed, requesting the paper sent for the amount of the enclosure but no name of State given, and often with the name of the post office also omitted. Persons should be careful to write their names plainly when they address publishers, and to name the post office at which they wish to receive their paper, and the State in which the post office is located.

BINDING—We would suggest to those who desire to have their volumes bound, that they had better send their numbers to this office, and have them executed in a uniform style with their previous volumes. Price of binding 75 cents.

INFALLIBLE RULE—It is an established rule of this office to stop sending the paper when the time for which it was prepaid has expired, and the publishers will not deviate from that standing rule in any instance.

FOREIGN SUBSCRIBERS—Our Canada and Nova Scotia patrons are solicited to compete with our citizens for the valuable prizes offered on the next volume. [It is important that all who reside out of the States should remember to send 25 cents additional to the published rates for each yearly subscriber—that amount we are obliged to pre-pay on postage.]

Money received at the SCIENTIFIC AMERICAN Office on account of Patent Office business for the week ending Saturday, Sep. 1, 1855—

I. F. B., of Ga., \$30; N. & S., of L. I., \$30; W. C. W., of Mass., \$10; F. & P., of N. Y., \$30; J. S. B., of O., \$30; H. & R. S., of Ga., \$25; N. W., of Ala., \$25; A. W. W., of Miss., \$20; W. N. M., of Mass., \$30; C. L. N., of N. Y., \$55; E. G., of N. J., \$25; J. H. S., of Mich., \$55; N. S. W., of N. Y., \$45; C. W. B., of Ct., \$10; J. S. T., of N. Y., \$30; I. J. O., of N. Y., \$30; S. A. H., of Mass., \$55; B. & H., of N. Y., \$25; J. G. K., of N. J., \$30; T. P., of Md., \$30; T. A. A. B., of Ga., \$50; H. H. F., of Miss., \$50; J. N., of N. Y., \$20; C. T. W., of Mass., \$30; J. K., of N. Y., \$15; P. V. W., of N. Y., \$30; S. P. B., of N. Y., \$55;

J. W. H., of N. Y., \$30; H. B. W., of Ct., \$30; C. L., of O., \$30; A. M. B., of N. Y., \$10; J. S. R., of Ala., \$35; M. & A., of N. Y., \$25; R. S. P., of N. Y., \$25; E. A. C., of Ct., \$30; J. C. S., of Mass., \$25; D. W., of N. Y., \$20; M. P. D., of N. Y., \$30; J. S. A., of Mass., \$55; T. G., of N. Y., \$25.

Specifications and drawings belonging to parties with the following initials have been forwarded to the Patent Office during the week ending Saturday, Sept. 1st—

C & W., of Tenn.; R. P., of London, Eng.; E. G., of N. J.; J. S. B., of O.; T. G., of N. Y.; N. W., of Ala.; H. & R. S., of Ga.; A. W. W., of Miss.; S. G., Jr., of N. Y.; R. W. B., of Mo.; O. W. M., of Ct.; A. F., of Mass.; C. L. N., of N. Y.; B. & H., of N. Y.; D. W., of N. Y.; J. H., Jr., of N. Y.; J. S. R., of Cal.; S. F. P., of N. J.; H. B. W., of Ct.; M. & A., of N. Y.; J. C. S., of Mass.; R. S. P., of N. Y.; H. S., of Mich.; N. & S., of L. I.; J. S. A., of Mass.

To CORRESPONDENTS—Our notices to correspondents are necessarily omitted this week.

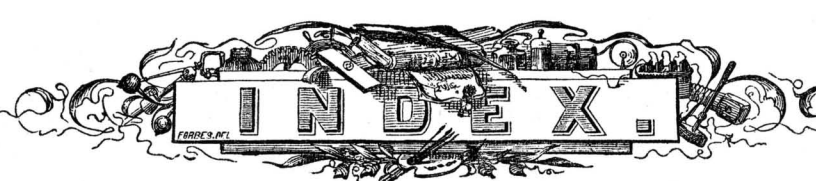

Agricultural Implements, Great Trial of 412
Ants, To Destroy 3, 222, 275
Apple Parer, Brown's, 2 figs. 380
Augers, Hoagland's, 1 fig. 293
Ballast Trimming for Steamboats Sedgwick's, 2 figs. 332
Balsam, Stryptic 161
Barrel Head Machine, Osborn's, 1 fig. 36
Barrel Head Machine, Heacock's, 1 fig. 308
Beans for soup 209
Bedsteads, Wardrobe, Hegeman's 44
Bedsteads, Invalid, Daniels', 1 fig. 356
Bevel Plane, Wheeler's, 2 figs. 249
Bit, Expansive, Gale's, 3 figs. 84
Bit, Fastening, Streeter's, 3 figs. 320
Bit, Fastening, Nichols', 3 figs. 336
Blacking, Waterproof 245, 347
Blackberry Cordial 350, 360
Blind Slat Machine, Sweet & Noyes' 28
Blind Slat Machine, Hastings' 116
Boilers, Steam, Bird's, 2 figs. 12
Boilers, To prevent Incrustations in, Wessensborn's 95
Boot Supperer, Dick's, 2 figs. 188, 228
Boot and Shoe Stretcher, Holden's 276
Boot Crimping Machine, Horton's, 2 figs. 352
Boring Machine, White's 258
Bottles, New, Brown & Bloeklen's, 2 figs. 16
Brake, Car, Rice's, 68
Brake, Steam, Wright's, 93
Brake, Car, Laughlin's, 100
Brake, Car, Loughridge's, 250
Brass, To Clean 9
Brass Formed by Galvanic Agency 160
Brass Kettle Machine, Camp's, 164
Bridges, Tubular 72
Bridge, Wire Suspension, Yandell & Johnson's, 3 figs. 105
Bridge, Fields', 4 figs. 185
Bridge, R. R., Gamble's, 3 figs. 408
Brick Kiln, Speights', 2 figs. 3
Brick Machine, Young's 160
Brick and Brick Work, Wire 300
Brick Patent, Till's, 6 figs. 400
Broth for Sick Persons 155
Bucket for Chain Pumps, Morris', 2 figs. 244
Bullets, Extracting 186
Bullet, Rifle, 2 figs. 245
Bullet Mold, Asher's 276
Butter Worker, Gore's, 1 fig. 44
Calf, Mechanical 338
Camphor, 406
Candles, Palm Oil 72
Candles, Tard 208
Carpenter, Ships, Holme's, 2 figs. 385
Cars, Burden, Hoyle & Kloh's 52
Cars, Railroad, Wright's 100
Car Ventilator, Marvin's 124
Car Ventilator, Corbett's 226
Car Ventilator, Abbott's, 3 figs. 273
Car Coupling, Hopkins', 3 figs. 324, 270
Carriage Wheels, Kelly's, 2 figs. 348
Carriage Measure, Coburn's, 4 figs. 360
Cart, Self-loading, Z. C. Butt's 218
Card Distributor, Duryea's 252
Carving Machine, Allen's 68
Casks, Turning from solid wood, Osborn's, 1 fig. 36
Castors, Furniture, Rour's, 2 figs. 208
Cement Hooks, 55, 157
Chain Hook, Straws, 1 fig. 21
Chain Link Machine, Wyckoff's, 3 figs. 122
Chair, Folding, Woodbury's 140
Chair, Cabinet, Adams's 252
Cheese, Making 62
Chickens, Remedy for the gapes in 313
Chisel, Mortising, Williams' 124
Chimney Safe, Clark's 195
Chloroform, Counteracted 139
Clamp, Board, Devine's 62
Clasp for Weaver's Harness, Copeland's, 1 fig. 376
Clay Kneading Machine, Thayer's, 2 figs. 376
Cloth Stretcher, Hilliard's 106
Clothes Drying Machine, Higgin's, 1 fig. 180
Clothes Pin Machine, Blake's 276
Clover Gatherer, Gage's 35
Coal, Substitutes for 48
Coal Ash Sifter, Sickle's, 2 figs. 60
Coal Hod, Martin's, 1 fig. 109
Cockroaches, to get rid of, 60
Cochineal, 238
Color and Dress 144
Compound Interest, 82, 90, 98
Condensers of Steam Engines 114
Corks, securing in bottles, Ashburner's, 3 figs. 253
Corn Planter, Redick's, 3 figs. 140
Corn Planter, Barnhart's, 3 figs. 200, 204
Corn Planter, Borden & McLean's 244
Cotton Heckler, Crenshaw's 60
Cotton, Sea Island 258
Cotton Gin, Fultz's 273
Cotton Press, Dederick's, 1 fig. 300
Cramp Carriage, Sandford's 83
Cream of Almonds, 136
Croup, Cure for 139, 202
Cultivator, Lichtenthaler's, 1 fig. 4
Cultivator, Robinson's, 1 fig. 257
Cutters, Cider Mill, Zeigler's, 2 figs. 20
Cutting Shavings for Upholsterers, Smith's 106
Daguerotypes Without a Camera 251

Damper for Chimneys, Fisher's, 124
Deck and Saloon Cabin for Steamboats, Jackson's, 2 figs. 343
Deodorizing Putrid Matter for Manure 272
Desks for Schools, Woodcock's, 1 fig. 20, 220
Directory for R. R. Stations, Richardson's, 235
Disinfectant, Cheap 395
Distances, Measuring by Sound 360
Dock, Sectional Floating, Everson & Ricard's 12
Document Holder, Woodbury's, 1 fig. 60
Doors, Weather Strip for, Croke's, 2 figs. 388
Dredging Machine, Howard's 234
Drill, Rock, Dunham's, 3 figs. 161
Dry Hand, Harris', 1 fig. 340
Driving Wheels, Chase's, 3 figs. 225
Dumb Waiter, Murtaugh's 244
Dyeing, Art of 122, 130, 133, 146, 154, 162, 170, 178, 186, 194, 202, 210, 218, 226, 234, 242, 250, 258, 266, 274, 282, 290, 304, 312, 320, 328, 336, 344, 352, 360, 368, 376, 384, 392, 400, 408
Elbows and Stove Pipes to cut by Rule, 2 figs. 50, 66
Elevatory, Castor Oil 194
Elevator, Oils', 1 fig. 85
Emery Paper 115
Engines, Hot Air, Napier & Rankin's 1 fig. 19
Engines, Steam and Ether 24
Engines, Re-acting Spring for 49
Engines, Oscillating, Woods', 6 figs. 217, 464
Engines, Fire, Adams, 2 figs. 315, 276
Engines, Rotary, Thomas', 2 figs. 250, 316
Erie R.R. Statistics 411
Escape from Houses on Fire 321
Essences, Flavoring 297
Excavator, Manure, Hurst's, 1 fig. 132
Excavator, Manure, Williams' 244
Faucet, Self-closing, Butler's 20
Faucet for Water Pipes, Fowler's 283
Feeder for Steam Boilers, Bee's, 3 figs. 429
Fellies, Machine for Dressing, Wyatt's 108
Felons, Cure for 115, 131, 203
Fence, Field, Prindle's, 4 figs. 73
Fence, Wire 130
Ferry Bridge, Lawrence's 228
Filter, Water, Saulsby's 63
Fires, Extinguishing, Loughridge's 250
Fire Arms, Neil's 44
Fire Arms, Newton's, 3 figs. 220
Fire Arms, Perry's, 3 figs. 304
Fire Alarm, Van Amringe's 411
Fish Hook, Cook's, 3 figs. 396
Flour Bolting Machinery, Hunt's 2 figs. 190, 484, 44
Flour Bolting Machinery, Taggart' 4
Flour Bolting Machinery, Stouffer's, 2 figs. 302
Flour Barrel, Pearsall's, 2 figs. 240
Fog Signals, etc. 3 figs. 312
Foot Rot in Sheep, Remedy for 179
Forging the Eyes of Suspension Rods, 5 figs. 232
Fork Bending Machine, Brand's 68
Freeing Steam Boilers of Sediment, Strait's, 2 figs. 252
Freeing Canal Boats from Water, Loughridge's, 1 fig. 148
Fruit Case, Rood's 4
Furnace, Hot Air, Carton & Briggs', 1 fig. 12
Furnace, Hot Air, Bartlett's, 1 fig. 193, 91
Furnace, Hot Water, Tasker's, 2 figs. 143
Furnaces, Regulating the Draft of, McDonell 150
Furnaces, Air Heating, Sutton's, 2 figs. 305, 218
Furnace, Charcoal, McNeill's 234
Furnace for Making Iron, Bell & Leet's, 2 figs. 239
Fuse, Tape, Bacon's 283
Galvanic Battery, Chester's, 2 figs. 329
Gas, Wood 50
Gas Generator, Porter's, 1 fig. 37
Gas Regulator, Dodge's, 2 figs. 108
Gas Regulator, Parham's 60
Gas Regulator, Woodruff & Palmer's 283
Gas Apparatus, Benzole, Mace's, 3 figs. 205, 154
Gas Cooking Stoves, Mayer's 260
Gates, Self-opening and closing, Phillips', 2 figs. 44
Gates, Circular, Thompson's, 1 fig. 393
Gates, Farm, Lum's, 1 fig. 353
Gates of Water Wheels, Todd's 196
Gauge for sitting lumber, Hart's, 3 figs. 364
Geology, Gold 51
Glass, American Plate 285
Glove for Plants 299
Governor for Steam Engines, Elliott's 236
Grain, Cleaning, Shearman's, 1 fig. 26
Grain Cleaning, Leach's 225
Grain, Drill, Palmer's, 2 figs. 328
Grain Mill, Leavitt's, 2 figs. 410

Granaries, Ford's, 2 figs. 215
Grease, Feeder, Sutton's 83
Guano, Substitute for 238
Gum, Mezquite 88
Gun for firing chain shot, Wolter's 226
Gyroscope, 138
Hair Wash 281
Hair Tonic 290
Hair Oil 347
Ham Baking 257
Hammer, Nail, Noyes's, 3 fig. 34
Hammer, Atmospheric, Hughes's, 3 figs. 65
Hanger for Shafting, Peal's 20
Harrow Teeth, Securing, Hagar's, 1 fig. 149, 20
Harness, Saddle and Trees, Selleck's, 4 figs. 164
Harvester, Lupton's 284
Hat Body Machine, Boynton's, 1 fig. 41, 2 figs. 90
Hat Felting Machine, Fuzzard's 136
Hay Press, Manny's, 2 figs. 392
Hemp and Flax Breaker, Hughes's 150
Hinge Machine, Miller's 204
Hog Pen, Hoffer's 114
Hog Pen, Abbe's, 1 fig. 308
Honey Mill, Brendenolph's, 2 figs. 268
Horse Shoeing Apparatus, Warlick's, 3 figs. 44
Horse Bit, Titus & Fenwick's 188
Horse Collar Block, Van Benschoten's, 1 fig. 404
Horse Power, Russel's 276
Horse Power, Fultz's, 1 fig. 385
Houses, Painting 90
Hub Boring Machine, Dole's 20
Hub Boring Machine, Casselman's, 3 figs. 89
Hydrodynamics 211
Hydrophobia 305
Ice Cream Freezer, Powell's, 1 fig. 292
Ice House, Parker's, 2 figs. 356
Ice Pitcher, Bakin's, 3 figs. 380
Implement for Boring the Earth, Adams' 172
Indigo, Florida 266
Infernal Machine, Russian, 4 figs. 368
Journal, Globular, Gill's 124
Lamp, Camphene, Bennett's 148
Lancaster Gun, 1 fig. 182, 165
Lantern, Morley's, 1 fig. 28
Lathe, Cahoon & Ross's 68
Lathe, Wentworth's 83
Lathe, Tugnot's 91
Lathe, Stephens's, 2 figs. 234, 194
Lathe, Bottom's 218
Lathe, Warth's, 2 figs. 377
Leather, Machine for cutting, Hathc & Churchill's, 12
Lemons, To Keep Fresh 25
Life Boat, Hodgson's 21
Life Boat, Burdan's 186
Life Boat, Smith's, 204
Life Boat, Allen's 210
Life Preserving Doors, &c., Phcott's 280
Lifting Jack, Carpenter & Powers' 100
Lightning and its Conductors 411
Lightning Conductor, Lyon's, 3 figs. 33
Liniment, Lethan 161
Lock, Yale's, 4 figs. 337
Locomotive, Dutcher's 263
Loom, Bag, Copeland's 83
Loom, Yates and Clayton's, 2 figs. 91
Lubricator, Regester's, 2 figs. 165
Lubricator, Sutton's, 2 figs. 201, 172
Lubricator, Dixon's 303
Manure, Artificial 280
Maple Sugar, Clarifying 197
Match Making Machine, Adler's, 2 figs. 114
Match Box Machine, Hawes's 163
Meat Biscuit, Borden's 157
Medical Inspirator, Tighlman's, 2 figs. 288
Melodeon, Carhart's 260
Metal, Uniting Plates of, Carhart's 4
Metal Bending Machine, Cumberland's 114
Microscope, Cheap 64
Milk Preserving 33, 64
Milk, Artificial 395
Mill, Flouring, Yule's 54
Mill, Grinding, Weigles's, 3 figs. 225
Mills, Fanning, Keach & Stillwell's, 1 fig. 364
Mill Spindle, Naracon's, 1 fig. 213
Mineral, Valuable 64
Minnie Ball, 163
Mixer Box, Spear's, 1 fig. 257
Molding, 11 figs. 192
Mortising Machine, Benton's 83
Moth Preventive, 290
Motive Agent, New 332
Mowing Machine, Palmer's, 1 fig. 328
Mowing Machine, Trial of, 335, 345, 365
Muntz Metal, for Bolts 187
Nail Machinery, 100
Odometer, Thompson's, 3 figs. 134, 17

Oils, Testing Lubricating 237
Ointment and Oil Elder flower 160
Ores, Treatment of 99
Paddle Wheels, Champion's, 2 figs. 8
Paddle Wheels, Wallis', 3 figs. 251, 258
Paddle Wheels, Dehart's, 1 fig. 372
Painting 131
Pain of the Heart, Cure for 130
Paper New Material for 9
Paper from Wood, Bowman's, 1 fig. 43
Paper Feeder for Printing Presses, Baldwin's 156
Papering Machine, Baker's, 1 fig. 181
Paper Stock, Machine for Washing, Peaslee's, 1 fig. 265
Paper Ruling Machine, Baldwin's, 268
Paste for Envelopes 235
Patent Safe Game, 2 figs. 381
Pavement Cast Iron 242
Pen, Glover's, 3 figs. 299
Pen, McClelland's, 266
Pendulum Detachment, Brown's, 2 figs. 176
Perfume Powder 224
Perfume of Flowers, to collect 249
Piercing Machine, Handkerchief 264
Photography 276
Philosophical Experiment, 1 fig. 272
Piano, Ackerly's 202
Pinch Bar, Coles', 1 fig. 73
Pions, Safety, Shaud's 28
Pipes, Metal Cutting, Brighton's 106
Pistol, Repeating, Beal's, 2 figs. 404
Planing and Matching Machines, Morse's, 1 fig. 393
Plow, Ditching, Lyon's 1 fig. 116
Plow, Standard, Esterly's 186
Plow, Warlick 244
Plow, Planting, Snell's, 1 fig. 280
Plow, Long Ice Cultivator, Hyde & Wright's, 2 figs. 284
Plow, Gang, Hildreth's, 1 fig. 324
Plug for Steam Boilers 107
Potato Digger, Bundy's, 2 figs. 16
Potato Planter, Anderson's, 2 figs. 236
Potato Planting, 773
Potato Cooking 104
Polygraph, Ames', 2 figs. 242
Pork, to Hestore 299
Preparation for Boots and Shoes 166
Press for Printing Colors, Brown's 156
Press, Hay, Mann's 290
Printer's Forms, Locking, Sprague's, 3 figs. 28
Propeller, Seibert's, 3 figs. 65
Propeller, Tyson's, 1 fig. 300
Pulleys, Securing to Shafts, Clarine's, 3 figs. 77
Pump, Chandler's, 1 fig. 9
Pump, Tower's, 2 figs. 68
Pump, Goring's 104
Pump, Burnham's 124
Pump, Cowing's 226
Pump, Carpenter's, 5 figs. 244
Pump, Wyckoff's 244
Pump, Kirkwood's, 2 figs. 396
Purchase suspended, Brown's 156
Quercitrine 155
Railway Chain Plate, Strait's, 2 figs. 62
Railroads, Improvement in 100
Railroad Tracks, Bakin's 26
Reaping Machines, History of, 89 figs. 24, 32, 40, 48, 56, 64, 72, 80, 88, 95, 104, 112, 120, 128, 136, 144, 152, 160, 168, 176, 178, 184, 192, 200, 208, 216, 224, 232, 240, 248, 256, 264, 272
Report of the Commissioner of Patents 110, 347
Rifle Breach Loading, Perry's, 3 figs. 4
Rifle Blasting Implement, Brown's, 2 figs. 25
Roller and Harrow, Hill's, 1 fig. 20
Rope Machine Robinson's, 4 fig. 17
Rose Bugs, to Destroy 297
Rotary Motion, Amadon's 20
Rule for Calculating the Weight of a Casting 243
Safes, Chimney, Clark's, 2 figs. 268
Salt, Manufactured of 114
Salt, Purifying 139
Salt, 165
Sanatory Substances, 301
Sash Fastener, Tyrrell's 152
Sash Fastener, Thomas' 64
Sash Fastener, Rode's 283
Sash and Molding Mill, Morse's, 1 fig. 249
Sashes, Adjusting, Payne's 283
Sausage Stuffer, Battle's 124
Saws, Cylindrical, Hays's 62
Saws, Filing, Buck's 68
Saws, Hanging, Chapman's 68
Saws Grinding, Clemson's 63
Saws, Reciprocating Ketcham's 124
Saw Mills, Andrew's, 2 figs. 66
Saw Mills, Brown's, 1 fig. 292
Sawing Down Standing Trees, Ludwig's, 2 figs. 410
Saw Mill Dogs, Russell's, 1 fig. 132
Sawing Firewood, Efferem's, 1 fig. 9
Sawing Machine, Young's, 3 figs. 212, 23
Sawing Machine, Fulgham's, 1 fig. 76
Sawing Machinery, Fulgham's, 1 fig. 409
Sawing Machines, Wicks', 1 fig. 97
Sawing Machine, Squire's, 2 figs. 129
Sawing Machine, Fox's, 2 figs. 401
Sawing Piles under water, Palen's, 2 figs. 116
Scaffold Brackets, Dixon, 5 figs. 124
Scales, Sampson's, 3 figs. 160
Scales, McPherson's, 2 figs. 221, 166
Scrofula, Cure for 166
Seed Planter, Andrews, 2 figs. 252
Seed Planter, Wakefield's, 2 figs. 369
Seed Ticks 68
Seeding Machine, Brown's 172
Separation, Grain, Barker's 4
Separation, Grain, Mackey & Smith's, 1 fig. 188
Separation, Grain, Bedwell's, 2 figs. 138
Separation, Grain, Bowen's, 1 fig. 201
Separation, Gold, Addison's 164
Sewing Machine, Van Geison's 98
Shaving and Felly Cutting Machine, Smith & Cowie's, 2 figs. 228
Shears Blade's, Welding Steel on 10
Sheep Shearing Machine, Lancaster's, 1 fig. 344, 266
Shingle Machine, Speed & Bailey's, 28
Shingle Machine, Conrod's, 1 fig. 180
Shot Explosive, Tibbal's, 44
Shoal Alarm, for Ships, Devlin's 124
Shutter, Fire Proof, Austin's, 93
Shutter, Iron, Mettam's, 68
Shuttle Guard for Looms, Harris', 234
Shuttle Improvement, Marble's, 276
Shuttle Improvement, Litchfield's, 276
Skates, Sanford's 196
Silk Manufacture in England 91
Silver Plate to Clean 16
Silvering Looking Glasses, Webster's, 283
Slate Frame, Young's, 12
Slate Cutting Machinery, Keyes', 1 fig. 409
Slate Quarrying, Brunner's, 5 figs. 204
Slide Rest, Van Horn's, 266
Slide Rest, Noyes', 268
Slide Valve Gear, Schenck's 268
Smoothing Irons, Heating, Boynton's, 3 figs. 190
Snail Use of 195
Snake Bites, Cure for 147
Soldering Machine, Stevenson's 164
Spark Arrester, Magoon's 52
Spark Arrester, Richard's 284
Spark Arrester, Wilder's, 2 figs. 140
Spark Machine, Woodton's, 4
Spark Machine, Richardson's, 2 fig. 84
Spiritual Machine, 1 fig. 162
Spirit Level, Evan's, 2 figs. 265
Spokes, Tenoning, Sibbett's, 3 figs. 52
Sportsmen, And Receipt for 267
Spring Balances, Beckwith's, 140
Spring Carriage, Murgatroyd's 268
Spike Machine, stationary, 1 fig. 101
Staging, Portable, Goolman & Morris', 1 fig. 340
Statistics of Patents in 1853 267
Statistics of Coffins 267
Steam Machine, Hutchinson's, 3 figs. 41
Steam Navigation, American 51
Steam Gauge, Beaumont, 2 figs. 92
Steam and Steam Boilers 274, 282
Steam and Steam Apparatus, Wethered's, 1 fig. 45
Steam Boilers, Champion's, 2 figs. 333
Steel Hardening 123
Steel Manufacturing, of, 3 figs. 403
Steel Goods, to keep from rusting 262
Stereoscopic Medallion, Mascher's, 1 fig. 189
Stone Dressing Machine, Porter's, 2 figs. 57
Stone Drilling, Davison's, 2 figs. 145
Stone Manufacturing, of, 3 figs. 403
Stone Dressing Machine, Dickson's, 2 figs. 141
Stop Cock, Coffin's, 2 figs. 200
Stove, Smoke Consuming, Hill's, 3 figs. 92
Stoves, Cleaning flues of Costley's 124
Stove Cutter, Gale's, 2 figs. 60
Straw Cutter, Squier's 172
Straw Cutter, Bennett, 196
Straw Cutter, Rose's 252
Straw Cutter, Simonton & Wicks', 2 figs. 338
Stud Fastener, Hopkins' 260
Stump Extractor, Vaughn's 83
Sugar Manufacture of France 281
Supplying Locomotives with Water, McDonald's, 2 figs. 127
Tanning, New Process, Enor's, 6
Tank, Locomotive, Collin's 12
Tape Worm Trap, Myer's, 2 figs. 384
Tea and Coffee Pot, McGregor's, 1 fig. 229
Tenoning Machine, Wardwell's, 1 fig. 345
Ticket Register, Apperley's, 1 fig. 316, 270
Tiles, Drain, Hill's 103
Toothache, Cure for 368
Tree nail Wedges, Jones & King's 202
Truck, Hand, Hutchins', 2 figs. 153, 182
Truss for Rupture, Marsh's 124
Turn Table, Robie's, 3 figs. 1
Turning the Leaves of Books, Bridg-ham & Stewart's, 3 figs. 76
Turning the Leaves of Books, Gallup's 260
Turpentine Distilling Apparatus, Blount's 384
Tuyes, Kellogg's 123
Type Setting Machine, Bowerman's 113
Valves, Steam Engine, Bates's 12
Valves Steam Engine, Tremper's 186
Valves Steam Engine, Bloomfield's, 2 figs. 122
Valves Steam Engine, Guild & Garrison's 236
Valves Steam Engine, Goodman's, 3 figs. 329, 244
Valves Steam Engines, Dubois's 108
Valves, Slide, Hick's, 1 fig. 196
Valves Slide, Bartholomew's, 1 fig. 264
Valve Hydraulic Ram, Webb's, 2 figs. 337
Valve Motion, Hubbard & Conant's 91
Varnishes 128, 208, 234
Washing Machine, Morgan's 218
Water Pipe in Philadelphia, 1 fig. 61
Waterproofing Process, 170
Water Gate, Todd's, 1 fig. 230
Water Wheels, Blackard's, 2 figs. 372
Water Wheels, VanDewater's, 1 fig. 321
Weights French, Reduced to English 50
Wheat, an article for food, 3 figs. 131
Windmills, Halladay's, 2 figs. 25
Windmills, Brown's, 2 figs. 156
Windmills, Lempecke's, 283
Windmills, Brown's, 4 figs. 361
Window Shades, Grant's, 106
Window Blinds, Fancy, Chase's, 2 figs. 410
Window Blinds, Ibel's, 150
Window Blinds, Blackley's, 163
Window Washer, 1 fig. 178
Window Screen, Webster's, 2 figs. 237
Windlasses, Ships, Emerson's 258
Winding up Lines, &c., Boardman & Sweet's, 262
Wood Bearings for Shafts, 1 fig. 333, 409
Wool Spinning Machine, Stoddard's Wrench, Hyde's, 226
Wrench, Everett's, 2 figs. 236
Wrench, Bristol's, 2 figs. 395
Yoke, Ox, Hammond's, 8 figs. 100
Yoke, Ox, Quimby's, 124
Patent Claims.
Accordeons, Tuning 322
Adding Numbers, Machine for 30
Adjusting Vessels upon the Keel 180
Blocks of Docks 86
Alarm, Burglars 70 [2], 142, 182, 346, 402
Anchors 246
Anchor Tripper 206
Anglers, 1 Boat and Sinker combined 118
Annunciators, Hotel 206
Apparatus to indicate the Locality of sunken Vessels 402
Apparatus for Determining the weight of Cargoes in Vessels 14
Apple Paring Machine 254
Applying Heat to dilate Gases to Elevate Water 14
Arrangement of Wheels, Axles, &c., 239
Augers 174, 230
Augers, Turning the lips of 230
Augers, Expanding 362
Auger Handle Fastening 214, 238
Axle Box Rollers 182
Axles, Car 70
Axles, Attaching Hubs to 294
Bag Machine, Paper 306 [2].
Balances, Spring 158
Balances, Platform 254
Balances for Time-keepers 142
Barrel Machinery 78
Barrel Heads, Cutting 206, 230
Bathing Tubs 392
Bath Tub, Plank for Molding 412
Bat for making Seamless Felt Garments 30
Bearings, Compensation 262
Bedsteads 246, 322, 362 [3], 306, [2], 354
Bedstead Rails, Cutting Screws on 298, 354
Bedstead Fastening 30, 245
Bed Bottoms, Spring 126, 346
Bee Hives 22
Bee Spreader 150
Bells, Alarm 46
Bells, Mode of Hanging 330
Bench Rest 314
Bench Plane 153
Benzole Vapor Apparatus 222
Bits, Bridle 190
Bleaching Apparatus 262, 299, 314
Blinds, Venetian 254
Blinds, Mortising 254, 362
Blind Adjuster 338
Blinds, Doors, &c. 338, 362 [2], 370, 366
Blind Slat, Tenoning 73
Block Nipper 298
Blocks, Building 158
Block for Horse Collars 330, 338, 346
Boats, Gutta Percha 370
Boat, Collapsible 412
Blowing Blasts, &c. 142
Boilers, Sugar 46
Boilers, Double Cylinder 86
Boilers, Steam 102, 110, 132, 254 [2], 298, 330, 346, 354, 394
Boilers, Feeding Water to 370
Boiler Alarm 110
Boilers, Water Gauge for 378
Boilers, Removing Incrustations 412

Bolt Machine 286, 364
Bolts, Dies for making 158
Bombs, Shells, &c. 78
Books, Paging 30, 300, 402
Books, Rounding the Backs of 110
Books, Trimming 412
Book Clipping 314
Book Crimping Machine 126, 278, 286, 314
Book Forms 254
Boots and Shoes 14, 238
Boot and Shoe Soles, Machine for cutting 142, 322 [2], 330, 370
Boot and Shoe Soles, Gutta Percha 322
Boot and Shoe Soles, Polishing 294
Boring Posts, &c. 364
Boring and Turning Wood 346
Boring Cylinder 330
Boring and Planing Metal Machine 142
Boring Machine 118, 206, 278
Bottle Fastening 362, 370
Bottles, Forming Screw Threads in the neck of 396
Boxes, Paper 158
Boxes, Cylindrical 174
Boxes, Wooden 142
Boxes, Sheet metal 94
Brace Bits securing in sockets 294
Brace for supporting garments 314
Brace for Piano Frames 143
Brackets 70
Braiding Machine 386
Brake for Vehicles 330, 230
Brakes, Car 46, 78, 86, 110, 142, 168, 230, 264
Brake Blocks for R. R. Cars 158
Brake, Process for making 214
Brick Kilns, 222
Brick, Manufacture of 230, 330, 322
Brick Machines 6, 38 [3], 54, 70, 338 [2], 314 [2], 412
Brick Molds 94
Brick Press 354, 298,
Brick Burning 314
Bridges, Swing 306
Bridges 402
Bridges, Ferry 222
Bridle Winkers 338
Bridle, Reins 370
Broom Corn, Cleaning 214
Brushes, 110, 143, 174
Buckles 78, 354
Buckets of Flutter Wheels 30, 378
Buckets for Pumps 166
Buckets of Paddle Wheels 322
Bullet Mold 193, 278
Bullion for R. R. Cars 322
Buoys for Raising Vessels 322
Burning Fluid 394, 306
Burners Fluid 193
Butt Hinge Machine 206
Butter Cooler 294
Butter Worker 182

Cabins, Floating 314
Cable Stoppers 174
Caldron and Furnace Combined 182
Calorifiers 46
Cans, Self-sealing 142, 362, 402
Cans, Sealed 154
Cans for holding Liquids 46
Cannon, Breech Loading 14, 166
Candlesticks 206, 402
Candle Mold Machine 150, 214, 370
Capstans for Ships 362
Car Coupling 362 [2]
Car Ventilator 174, 230
Car Brake 338, 30, 394
Car Seats 330, 22, 30, 46, 110, 246, 402 [2]
Car, Dumping 35
Car Wheels, Forging 142
Cars, Running Gear of 110
Cars, Retaining on the track 182, 330
Cars, Excluding dust from 378
Cars, Apparatus for starting 93
Cars, Replacing on the track 394
Carriages 166, 370, 412
Carriage Seats 166
Carriage Wheels 174 [2], 2, 3
Carriage Bodies, Hang 9, 118
Carriage Tops, Setting Hows to 346
Carriage Coupling 114
Carriage, Joint Bodied 294
Carriage for Steam Fire Engine 298
Carpet fastening 330, 354, 311
Carpets and Rugs 62, 386
Carpets, Securing Floors 118
Cars, Self-loading, &c., 222, 230, 278
Cartridges 70, 230, 306
Carding Machine 206
Cards, Cleaning 94
Card Exhibitor 254
Casters for Furniture 290
Catch for Breast pins 214
Center Bit fastening 154
Chairs 233
Chairs, Dentists 306, 386
Chairs, Cabin 254
Chairs, Frames 30
Chairs, Rail Road 46, 142, 62
Chair and Cushion Machine 182
Chain Silk Machine 203
Cheese Vats 118
Chimney Caps 6
Chimney Safes 193
Chimney for Steam Boilers 190
Chlorine, Compounds for neutralizing 46
Chuck for turning Eccentrics 330
Chuck for turning Elliptical Cylinders 142
Churns 110, 142, 182, 190, 338, 362, 394
Cider Mills 306
Clay Pulverizer 354
Clay Knitting Machine 314
Clamp, Clothes 94
Clamp for lumber jointing Machine 233
Clocks, Callender 22 [2], 371
Clocks, Electric 30
Clock Fronts, 51, 236
Cloth, Drying 386
Clothes, Ornamental Felt 311
Clothes, Waterproofing 114
Clothes Drying Apparatus 94
Clothes Pin Machine 278
Clover Hauler 102, 174, 190
Clover Seed Cleaner 206
Coal Distilling 378
Coal Cars, Hoisting and Dumping 246
Coal Screen 214, 230
Coal Holes 246
Coal Hoies, Covers for 246 [2],
Coffee Roasters 395
Coffins 118, 166, 222, 338
Coke Oven 153
Composition for treating Rubber and Gutta Percha 394
Cone Valves, Two motion 330
Condensers for Steam Engines 14, 70, 118, 126, 245
Condensers for Fibrous materials 294
Cord, Planing and Twisting 206, 286
Cordure Machinery 298
Cork Machinery 347
Cork Planter 278, 330, 333, 346 [2], 336, 394
Corn Shellers 14, 78 (2), 206, 333, 346
Corn and Cob Crusher 182, 306, 402
Cotton Thread, Covering with Wool 110
Cotton Gins 142, 190, 246, 293, 338, 394
Cotton Gin Saws 412
Cotton, Ginning and Cleaning 46, 62, 126
Cotton Picker 70
Cotton Seed Planter 294
Cotton Seed Milling 238
Counting Machine 22
Coupling, Car 8, 214, 254
Coupling for Organs, &c. 322
Cracker Machine 190
Cramp, Carriage 150
Crank Connection 142
Crescenting the edges of Leather Straps 294
Crest Sheet Metal Pipes 306
Cross Head Attachment 362
Crowbar 166

Cultivators 86 (2), 142, 198, 214, 222, 230, 238 (3), 246, 264, 262
Cultivator Teeth 174
Curbs for Water Wheels 298
Curtain, Fixtures 6, 14, 33, 42, 166, 222, 246, 294 (2), 402
Cut off Valve 306
Cutters for Rotary Disks 330
Cutter Head for Irregular Forms 370
Cutting Cavities 346
Cutter Head for Irregular Forms 386
Cylinders, Turning Wooden 374

Daguerreotype Cases 38, 206, 386
Daguerreotype Plates, Polishing 22, 230
Daguerreotype Plate Holder 182, 254
Daguerreotype Mats, Beveling, &c. 346
Dampers for Ovens 46
Derricks 362
Desks for School Rooms 214
Dies for Copper Tube Machine 174
Dies for Bolt Forging 262
Dies for Ornamental Metal Tubes 245
Ditching Machine 222
Dock Holders for Horses 118
Doors 330
Doors for Baggage Cars 6
Door Fasteners 8, 204
Door Knobs 158, 402
Dough, Machine for Kneading 150
Dove-Tailing Machine 142
Drawbridge, R. R.
Drawbridge and Switch Telegraph 38
Draft in Locomotives 354
Drains for Sewers 314
Dredging Machine 150, 262
Dressing Conical Surfaces 346
Drills, Rock 46
Drills, Pawl 46
Drills, Metal 102
Drills for Artesian Wells 254
Drill Machine 336
Dry Docks 110
Dumb Waiters 2, 6
Duster, Bran 62
Dynamometers, Registering 126

Ear Trumpet 306
Elastic Goods 30
Engines, Air 22, 378
Engines, Air and Steam 354
Engines, Fire 14, 102 (2), 166 (2), 206 (2), 278
Engines, Gas 262
Engines, Hydro pneumatic 254
Engines, Locomotive 30
Engines, Exhaust Pipes in Locomotive 214
Engines, Oscillating 14, 118, 150, 166, 298
Engines, Rotary 62, 78, 262 (2), 330
Engines, Vapor 306
Engraving, Calico Printers Rollers 402
Entry Lights 180
Evaporating Apparatus 222
Excavators 86 (2), 246, 298, 354, 362
Excluding Dirt from R. R. Rails 222

Fabrics Printing Textile 386
Facing Bed for Grinding Granite 286
Fans, Revolving 126
Fans, Wheel 322
Fan Blower 330, 362, 378
Fatty Bodies, Purifying 322
Faucets 236 (2), 306, 322, 394
Feed Motion for Sawing Lumber 118
Feeding Water to Steam Boilers 314
Fellies, Dressing 118
Felt Goods, Manufacturing 182
Fences 298
Fermenting Tuns for Beer 142
Ferry Boats, Guard for 123
File Cutting 370
Filter 322 (4),
Filtering Apparatus for Steam Boilers 168
Fire Arms 22 (3), 30, 46, 62, 70, 78, 86, 102 (2), 142, 198 (3), 174, 206 (3), 222 (3), 230 (2), 246 (4), 264, 286, 298, 322, 346, 362 (3), 378, 402, 412
Fire Extinguisher 110, 222
Fire Proof Floor and Ceiling 246
Fireplaces 70, 214, 378
Fish Hook 330
Fish for Manure, &c. 214
Flags, Signal 142
Flag Dresser 6
Flax and Hemp Breaker 6
Floors, Prepared 386
Flour Bolt 4, 182, 198
Flour Packing Machine 126
Flour, Drying and Cooling 347
Fluids, Distributing 14
Flyers 118
Forceps, Surgical 94
Forging Machine 306, 394
Forks and Spoons 230, 246
Forks for Gold Diggers 206
Freezing Steam Boilers from Sediment 246
Freezers, Ice Cream 6
Friction Rollers 254
Fruit Dryers 142
Fuel, Artificial 142, 322 (2), 286
Furnaces, Hot Air 30, 38, 62, 118, 166, 174, 206, 294, 298, 322, 330, 378,
Furnaces, Soldering 70
Furnaces, Glass 78 (2),
Furnaces, Iron 60
Furnaces, Zinc White 174, 370
Furnaces, Feeding Fuel to 230
Furnaces for Heating Buildings 78, 314, 394 (2)
Furnaces, Charcoal 238
Furnaces for burning Wet Fuel 254
Furnaces for Locomotives 362
Furnaces for burning Gas 278
Furnaces, Steam Boiler 333
Fuse Tape 286
Fuse Stock for Bomb Shells 338

Galvanic Battery 294
Garments, Fastening for 38, 46
Gas Generators 30, 262
Gas from Wood 30
Gas Retort 38, 262
Gas Meter 38
Gas Heater 166
Gas Purifying 214
Gas Regulator 222, 254, 286, 306, 314, 354, 384, 394
Gas Burners, Valves for 222, 388
Gas Burners, Regulators for 14
Gas Lighter 338
Gas Burning Gridirons 362
Gates, Farm 78, 278, 298
Gates, Self-regulating Water 198
Gates, Opening and Closing 246, 298, (3), 395, 402
Gates, Balance Water 370
Gates Circular 322
Gauge, Steam 38, 402
Gauge, Saw 86
Gauge, Slitting 294
Gauge for Stair Rails 354
Generators, Steam 182, 254
Glass Toilet, Joint for 54
Glass, Manufacture of Plate 354, 337
Glue, Clarifying 174
Gold Collector 118
Gold Washer 157
Governors, Combination of 238
Governors, for Marine Engines 357, 394
Granaries 62
Grain Mill 200
Grain Cleaner 222, 246, 322
Grain Drying 298
Grain, Measuring and Weighing 336
Grain Drills 313
Grate Bar, 70, 294, 306
Griddle 198
Grist Mill 14

Guards for Door Locks 214
Guard Rails for R. R. 322
Guides for Hemming and Carding 286
Guides, Mandrel 338
Gums, Vulcanizing 78
Gun Locks 394
Gutta Percha Stereotype Composition 62
Gutta Percha, Desulphurizing 78
Gutters for Buildings 222

Handles, Turning Fancy 150
Hand Rails for Stairs 166
Hanging Plane Stocks, &c. 346
Hammers, Forge 270
Hammers, Trip 346
Harness, Weavers 142
Harness, Saddle Trees 214
Harness, Saddles 78
Harness, Clasp for Looms 30
Harness for Looms 338
Harrows 118, 198, 241, 254, 372
Harvesters 22 (2), 30, 54, 86, 110, 198 (2), 142 (2), 143 (7), 150, 158, 174 (3), 182 (2), 190, 214 (4), 230, 238, 246, 264, 262 (3), 270 (3), 286 (2), 294, 298, 306, 314, 322, 346 (2), 364, 362, 370, 394, 402, 412
Harvester Rakes, Motion of 330
Harvester, Attaching Rakers Seat to 338
Harvesters, Cutters of 338, 346, 354, 394
Harvesters, Guard Fingers of 338
Harvester Reels 333
Harvester Rakes 70, 94, 412
Harvesters, Changing from Reapers to 338
Hats, Ventilating 378
Hats, Manufacture of 142, 314 (2)
Hat Bodies, Felted 30, 174, 190, 364
Hat Bodies, Making 38, 46, 78
Hat Bodies, Sizing 370
Hat Bodies, Trimming 54
Hats and Bonnets, Pressing 182
Hat Making Machine 166, 262
Hay Press 262
Head Supporters for R. R. Cars 190
Heater, Air 193
Heating Wrought Iron Wheels for Forging 322
Heating Feed Water to Steam Boilers 346, 362
Heels for India Rubber Soles 363
Hemp Rotting Process 94
Hemp Cutters 402
Hides, Unhairing 142
Hinges 412
Hinges of Rolling Iron Shutters 270
Hinges, Spring 294, 371
Hoes, Coal 78
Hoes 118
Hogs, Machine for Slaughtering 190
Holding Vessels in Docks 126 (2)
Hominy Machine 294
Hones, Metallic 362
Hooks and Eyes, Attaching to cards 386
Hoops, Manufacturing 198
Hoops, Cutting Locks of &c., 330
Hoop Jacks for Sailing Vessels 222
Hop Extrating Apparatus 150
Hop Frames 190
Horn, Splitting 43
Horse Shoe Machine 126
Horse Collars, Stuffing 214
Horse Power 262, 278, 299, 346, 355
Hose Coupling 246, 293, 300
Hot Water Apparatus 395
Hubs, Turning 46, 370
Hubs, Boring 254, 370
Hub Band for Carriages 118
Hub and Axle Fastening 306
Hullers, Buckwheat 298
Huller, Cotton Seed 70

Ice House 330
Ice Pitcher 338
Inhaling Apparatus 94
India Rubber Cloth 142, 174
India Rubber, De-vulcanizing 306
Inkstand 386, 412
Ink, Printers 362
Instrument for Cutting out Stone 166
Iron Beam for turning Flanges on 142
Iron Building 54, 14, 386
Iron Bridges 54
Iron Enamelling 54
Iron Wrought from the Ore 62
Iron Smelting 370
Iron Compressing 378
Iron Rolling 142
Irregular Forms, Cutting 412

Joints for Stove Pipes 330
Joints of Pipes for Artesian Wells 330
Journal Boxes for Carriages 142
Journal Boxes, Packing for 38
Journal Boxes, Alloys for 178, 394, 402
Journal Boxes, Glass 402

Kerosene, Manufacture of 238
Kettles, Machine for forming 150
Knives for Calcining Plaster of Paris 94
Key for Tuning Pianofortes 70
Knife for Cutting Leather for Whips 70
Knobs for Curtains, &c. 230
Knitting Machine 30, 38, 102, 110, 298 (2), 346, 362

Labels for Bottles, &c. 377
Ladder, Fire Escape 46
Lamps 6, 22, 30, 46, 94, 222, 130, 286, 346, 362
Lamp Caps 86, 190
Lamp Shades 153
Lamp Shade Protector 246
Lanterns 62 (2), 174 (2), 102, 150, 166, 362 (2), 402
Lancet 246
Lathes 46, 102, 394 (2)
Lathes, Slat Rest for 198, 262 (2), 394
Latches for Door 174, 346
Leather Banding 78
Leather Splitting Machine 136, 190, 377
Leather, Composition for Dressing 144
Leather Extractive Tannin from 42
Leather, Japanese 90
Leather, Bleaching 166
Leather, Polishing 78
Leather Straps, Shearing 106
Legs, Artificial 378, 386
Legs for Pianos, &c. 354
Life Boats 14, 190, 14, 230
Life Preserving Seats, &c. 126, 142, 150, 185, 396, 402
Lighting Rods, Attachment for 346
Lifting Jacks 78, 166, 132
Lights, Vault 4
Lime Kilns 158, 412
Loading Rifled Cannon 246
Locks 78 (2), 118, 158, 198, 222, 246, 322, 389, 396
Locks for Fire Arms 142
Locks, Alarm for 78
Logs, Controlling in Saw Mills 86 (2)
Looms 38, 46, 54 (2), 62, 86, 10, 118, 142, 150 (2), 156 (2), 166, 230, 238 (2), 246, 270, 306 (2), 314 (2), 346 (2), 354, 353, 371, 386
Looms Operating by Electricity 118
Looms, Temple for 158, 94, 337
Looms, Shuttle Motion of 396
Lubricants 153, 138, 78, 94
Lubricating Compounds 62, 298, 306, 354
Lubricating Cylinder of Steam Engines 94, 110
Lumber Dressing 371
Lumber Sawing 385

Mandrel for Holding Carriage Hubs 206
Mandrel for Cutting Tapering Sticks 298
Mandrel Circular Saw 378
Marquetry 166
Mat Hoops 70
Mats, Machine 150
Match Frames, Filling 70
Match Machine 166
Measures for Tailors 70 (2)
Meat Chopping Machine 190
Meat Curing 222
Medicine Administrator 370
Metal Bars, Straightening 126
Metal Bars, Reducing 294
Metal Folding Machine 166
Metal, Cutting Sheet 370
Metal Supplying Furnaces 166
Metal Tubes, Rollers for making 262
Metals, Amalgamating 306
Metals, Bending 118
Metals, Burnishing 278
Meter, Water 54, 70, 158, 370
Meter, Dry Gas 110
Meter, Fluid 94
Mills 62, 110, 136, 143, 150, 182, 347, 394
Mills, Grinding Surface in 54
Mill Bushes 62, 322
Mill Stones, Dressing 6, 14, 22, 94, 198, 330
Mill Stones, Hanging 386
Mill Step 346
Miter Box 102, 278
Miter Machine 214, 306
Miter and Bevel Square 338, 294
Mitering Printers Rules 346
Minerals, Machine for Crushing, &c. 18
Molds for Pressing Bonnet Frames 102 (2)
Molding Machine 168 (2)
Mortising and Tenoning Machine 230, 346
Mortising Machine, Feeding 166
Mosquito Curtains 38
Motion, Converting Reciprocating into Rotary 102
Moving Stereoscopic Pictures 330
Mowing Machine 206, 230, 306, 314, 346, 412
Mule, Self-acting 38
Multigrad Iron Screw 86
Musical Instruments 6, 86, 378
Music, Composing 314

Nail Machine 126
Needles, Sewing 38
Nozzle for Hose Pipes 286
Nut Machine 150, 331 [2], 362

Obstetrical Extractor 402
Odometer 70 [2]
Oils, Fictitious 246
Oil Cloth, Printing 314
Oil Dippers 378
Omnibus Register 86
Ordnance 222, 362
Ore, Machine for Crushing 110, 150
Ore, Working Franklinite 174
Ore, Cleaning 333
Ovens for Baking 110, 378
Oven for Cooks, Range 126
Overshoes, India Rubber 86

Packing for Stuffing Boxes 333
Paddle Wheels 38, 166, 206, 246, 346
Paddle Wheels, Feathering 102
Paddles, 143
Pads for Trusses 306
Pain for Cooks, Range 126
Paint Mill 198, 254
Palate for Artificial Teeth 14
Paper, Polishing 62
Paper Making Machine 110 [2]
Paper Stock, Washing 166
Paper, Strip, & cutting of 182, 866
Paper from Bark 185
Paper feeder for Printing Presses 6, 142, 198, 246, 254, 370, 346, 270
Paper Box Machine 222
Paper Mill Machine 262
Paper Bag and Envelope Machine 278
Papering Walls, Machine for 262
Parrel and Bow 30
Pavements, Cast Iron 142 [2], 262
Pegging Machine 306
Pendulum for Time Pieces 150
Penmanship, Teaching 190
Pen Fountain 166, 262
Pen Holder 62, 254, 262 [70]
Pen and Pencil Case 38 [2], 54, 62 [2],
Pencils for Drawing 94
Pencil Sharpener 262
Pianoforte Stools 38
Pianofortes 142, 174, 182, 262, 270, 330
Pianoforte Frames 206
Pile Driving, Atmospheric 142
Pilk Making Machine 306
Pin, Sewing 38
Pin Sticking Machine 306
Pipes, Water 54
Pitchers, Molasses 386
Plane Stocks, Hanging 6
Plane Stock, Iron 278
Plane Straper 336
Planes, Shoemakers 45
Planing Machine 102, 206, 294
Planing Machine, Cutter Heads for 33
Planing Machine, Presser Bar for 94
Planing Machine, Feeding Planks to 378
Planing Machine, Hanging the Knife in 142
Planing and Matching Machine 150
Planing Metal, Machine for 270
Plank Hoofs for buildings 322
Platform, Folding 402
Plows 62, 86, 158, 174 [2], 190 [3], 246 [2], 278, 286, 330, 346, 412
Plugs for Lubricating Axles 153
Polishing Machine 38, 222
Polypus 118 [2]
Porfolios 314
Posts, Fence 278
Potato Digger 78, 262, 286, 306, 322, 370
Potash and Soda 370
Powder Flasks 70
Presses, Printing 38, 143 [2], 230 [2], 322, 370, 394
Presses for Printing Colors 70, 142
Presses, Hay and Cotton 102, 246, 394
Presses, Cheese 371
Presses, Cotton 322, 345, 313
Preparing Liquids for Aiding Digestion 236
Printing Blocks 86
Printing from Engraved Plates 150
Prismatic Foams, Turning 126
Propellers 150, 206, 232, 286, 306, 322, 370
Projectiles, Molds for 153
Projectiles, Press for making 230
Projectiles, Press [2], 402
Pulleys, Attaching to Shafts 6
Pulleys, Bearings for 62
Pumps 14, 22, 48, 110, 126, 150, 174 [2], 178 [2], 214, 270 [2], 283 [2], 246 [3], 378, 392
Pumps, Piston for 14, 215, 370
Pumps Operating by Wind 222
Pump Air Chamber of 230
Pump, Elastic Rubber for 232
Pump, Ship 354
Pump, Water for 354
Pump, Operating Valves of 362
Pump, Wrecking 362
Punching Machine, Metal 262 [2]
Purchase, Suspended 142

Quartz Crusher 110, 299

Rails, Rolling R. R. 286
Rakes 142, 190, 362
Rakes and Elevators 230, 246
Railway Chairs 370
Rams, Hydraulic 22, 110
Rattan Machine 118, 142, 378
Refrigerators 150, 370
Refining Jewellers Scraps 238
Regulating Furnaces of Hot Water Apparatus 110, 118
Regulators for Steam Engines 118, 314
Rifling Machine 166
Rigging Machinery for Worming 6
Riving Machine 6
Rive Machine 346
Roads, Repairing 182
Rods and Tubes, Metal 102
Roller Catch in Self-Acting Mule 62
Rollers, for Pattern Chains for Looms 86
Rollers for Corrugating Sheet Metal 166
Rolls and Drier for Paper Making 206
Rope and Cordage Machine 46, 70, 102, 354, 370
Roving Regulating the size of 142
Rubber Compounds, Re-working 150

Saddle Trees 262, 298, 354
Safes 62, 238, 294
Salt, Manufacture of 46
Salting, Process of Treating 118
Sand Paper Cutting Machine 346
Sand Washer 346
Sash Fastener 126, 222, 262, 294, 412
Sash Supporter 278, 286
Sash Clamping Machine 278
Sashes, Window 286, 322, 338, 394
Saucers 94
Sausage Stuffers 22
Saws, Cotton Gin 412
Saw Frames 33
Saw Gummer 46
Saw Plates 214
Saw Teeth 254
Saw Spindles 254
Saw Mills 322
Saw Sets 142
Saws, Stone 38, 286
Saws, Flattening and Tempering 70
Saws, Reciprocating 198, 254
Saws, Hand 38, 78, 142, 150
Saws, Circular 78, 142, 150
Saws, Straining 394
Saws, Hanging 36 [2], 412, 412
Sawing Machine 22 [2], 54, 142, 174, 322 [2], 370, 378, 394
Sawing Firewood 22, 278
Sawing off Piles under water 70, 278
Sawing Wedges or Shingles 286
Sawing a Log by its own weight 286
Sawing and Planing Clapboards 294
Scaffolds 142, 330
Scales 30, 153, 354, 370, 412
Scrapper for Boots and Shoes 246
Screw Blank, Threading 94
Screw Jacks 266
Screw Fastening 346
Seythe Fastening 94, 322, 412
Seats for Public Buildings 102, 110
Seats for Wagons 70
Seed Planters 6 [2], 62, 94 [2], 118 [3], 142, 153 [3], 136, 174 [2], 132, 206 [2], 222, 238 [3], 238 [2], 246 [2], 294, 230, 298 [3], 314 [2], 370, 336
Seed Drill 330
Seeding Machine 333, 378
Separators, Gold 22, 230
Separators, Grain 38, 62
Separators, Metal 123
Separators, Flour and Bran 222
Sewing Machines 14, 38, 78, 86, 4, 102, 136, 142, 182, 138 [2], 14, [2], 132, 190, 153, 230 [2], 262, 278, 294 [2], 299 [3], 306 [322] [2], 346 [3], 354, 362 [378] [2]
Sewing Machine Cases 412
Sewing Bird 306
Sewing, Arranging at an angle 278
Shafts, Wrought Iron 371
Shears, Tailors 14
Sheep Shearing Machine 270
Sheet Metal Folding Machine 322
Ships, Construction of 46
Ships, Standing Rigging of 190
Ships Riding 246
Ships, Ventilator for 314
Ships Spars 354
Ships Iron 362
Shingle Machine 22, 46 [2], 70, 86, 94, 126, 142, 150, 234, 286, 346, 402
Shovel Handle Machine 78, 330
Shovel for Grain Mills 306
Shuttle for Looms 27 [2], 371
Shutters, Metallic Slat 14
Shutters, Rolling Iron 153, 294, 412
Sifting Apparatus 394
Sifting and Bolting Machine 62
Signals R. R. 394, 386
Sizing, Framing at 286
Silvering Looking-glasses 286
Skates 198 [2]
Skiving Boot and Shoe Counters 314
Slate Machine 142
Slate, Machinery 142
Sleigh 222, 294
Slingers, Cutting Wood into 198
Smut Machines 46, 54, 62, 86, 182, 286
Soap Making 142
Soap Cutting Machine 378 [2]
Socks, Handles for 100s 350
Soda Water Apparatus 214 [2], 322
Spark Arresters 70, 153, 286, 294, 298, 354
Spade Plows 206
Spikes 293
Spinning Frames 94, 314
Spinning Machine 294
Spinner, Catch Fish 322
Spiral Wheel for Replacing Cars on the Track 254
Spirit Levels 190
Splice Piece for Railways 254
Spoke Machine 14, 206, 357
Spoons 347
Spring, Metallic 198, 294
Spring Wagon 214
Springs, India Rubber 262
Springs, Carriage 270, 294
Springs for Hinges 330
Springs, Pneumatic 344
Springs, Rollers for Curtains 278, 294 [2]
Spurs 174
Square, Scale, Level and Bevel 62
Staff Screws for Ship Carpenters 174
Staging, Portable 22
Stages, Portable
Stalk Cutter 41
Stalk Gatherer 394
Stalls for Horses 370
Stamp, Hand 206, 370, 402, 412
Starch Apparatus 236, 371
Statue, Egyptian 294
Staves, Bolt for 78
Stave Machine 150, 298, 322 [3], 354
Stays for Presses 184
Steam Machinery 156
Steam, Regulating Discharge of 278
Steering Apparatus 110, 155, 214
Stereoscopic Case 203
Stereoscopic Medallion 153
Stereotyping Apparatus 142
Stilk, Rosin 29, 354
Stone Dressing Machine 78, 78, 371
Stone Polishing 78, 270
Stone Carving Machine 83
Stone Pasteboard 222
Stone, Machine for Raising 254
Stone Sawn Machine 330
Stone, Artificial 330
Stoppers of Bottles 78, 150, 222
Stock Cocks 150, 402
Stop Water for Ships 354

Stoves and Ranges 14, 38, 54 [3], 62, 78 [3], 102 [3], 110, 118, 143 [4], 166 [5], 180, 198, 206, 214, 230, 270, 286 [2], 306 [3], 346 [2], 370, 395
Stoves, Gas Cooking 206, 262
Stove Pipe Tube 246
Stove Plates 338, 395
Straw Cutters 14, 30, 158, 174, 198, 254
[5], 306, 338, 364, 384, 412
Street Sweeping Machine 182
Stretchers for Boots and Shoes 278
Stud and Button Fastening 262
Stump Extractor 214, 222, 330
Sugar Making Apparatus 46
Sugar Molds 126
Sugar Mill 362
Sugar Draining 354
Sulphurets, Treating 306
Sunac Mill 214
Swell for Moledeons 298
Switches R. R. 110
Swimming Glove 402
Swivel for Watch Chains 230
Syrphon, Attachment to 70

Tables 6, 230
Table Leaves, Supporting 238
Table and Desk combined 270
Telegraphic Apparatus 336
Tenoning Machine 198, 206, 322
Tenoning Tool 294
Thrashers and Cleaners of Grain 190
Thread Dressing 294
Thread, Twisting 362
Throshles for Spinning Cotton 118
Ticks, Heater 278
Tidal Alarm Apparatus 338
Tide Machine 362
Time Keepers 402
Tires, Securing to Wheels 386
Tobacco, Substitute for 198
Tobacco, Pressing in Plug 322
Tool for Grooving Molds 286 [2]
Tooth Clothing for Picking Cylinders 70
Tongue Iron 336
Tonguing and Grooving Machine 142
Tops for Carriages 262
Topsails, Reefing 6, 110, 306
Towel of Clothes Horse 102
Trap, Mole 14
Trap for Animals 78, 142, 412
Trap, Tape Worm 86 [2]
Trap, Rat 293
Trees, Sawing 286, 362
Trenail Machine 298, 362
Truck, Hand 158
Truck, Locomotive 182
Trusses 14, 166, 394
Trussing Yards to Vessels' Masts 113
Tubes, Roving 54
Tubes, Metal 150, 362
Turning the Leaves of Books 14, 202
Turning, Boring and Slotting Machine 222
Turpentine, Distilling 286
Type Casting 86

Umbrellas 298
Uterine Supporters 306

Valves, Steam Engine 78, 190, 222, 230, 238, 246, 294, 375 [2]
Valve, Slide 86, 94, 102, 142, 150 [2]