

Scientific American.

THE ADVOCATE OF INDUSTRY, AND JOURNAL OF SCIENTIFIC, MECHANICAL, AND OTHER IMPROVEMENTS.

VOLUME X.]

NEW-YORK, AUGUST 18, 1855.

[NUMBER 49.

THE
Scientific American,
PUBLISHED WEEKLY
At 123 Fulton Street, N. Y. (Sun Buildings.)
BY MUNN & COMPANY.

D. D. MUNN, S. H. WALES, A. E. BEACH.

Agents,
Federhen & Co., Boston. Dexter & Bro., New York
A. Winch, Philadelphia. E. B. Fuller, Halifax, N. S.
A. G. Courtenay, Charleston. S. W. Pease, Cincinnati, O.
Avery, Bellford & Co., London. M. Gardisal & Co., Paris

Responsible Agents may also be found in all the principal cities and towns in the United States.

Single copies of the paper are on sale at all the periodical stores in this city, Brooklyn, and Jersey City.

TERMS—\$2 a year—\$1 in advance and the remainder in six months.

Street Pavements.

Five years ago, in the SCIENTIFIC AMERICAN of June 1st, 1850, we presented three engravings of different kinds of pavements for streets, and expressed our opinions of the kind that would be the best for this city. At that time there were two kinds of pavements in use, viz.: the old cobble stone and the Russ; (Perrine's was just being laid.) We presented reasons against the cobble stone, Russ, and Perrine kinds, and advised our city authorities to adopt the small oblong trap block pavement, illustrated by one of the figures referred to. There was not then a single yard of such pavement in our city, but now quite a number of streets have been laid with it, and such has been the satisfaction it has given, that in a very few years the whole of our city will be paved with no other kind, as street after street of the old cobble stones are being lifted, and the beautiful little oblong blocks laid down in their place. It affords us no small degree of pleasure to witness our city authorities adopting any useful suggestions for the benefit of the city; but the greatest pleasure we have experienced relating to our new pavements, is to behold the satisfaction it has given to our carmen, and to hear the praises it has received from all our citizens.

The Ericsson under Steam.

The *Nautical Magazine* contains a letter from J. B. Kitching, one of those who went to Havre in the Ericsson,—giving an account of the voyage. We must say that its tone is not good, as it makes a charge against some "steam friends" who doubted that the Ericsson could be propelled faster, at a less cost, than other boats. For the horse power expended by her, in the passage across the Atlantic, we do not see that she consumed any less fuel than some other steam vessels. She was in ballast trim—having taken no cargo—yet it took 14 days to reach Havre. The economy of fuel by the Ericsson, (22 tons per diem,) if correctly stated, is a strong argument in favor of steam, and is equally so against hot air.

Rain fell during nineteen days last month. It has been the most rainy summer in sixty-seven years.

Improvement in Horse Powers.

The annexed figure is a perspective view of an improvement in horse powers for which a patent was granted to H. H. Fultz, of Lexington, Holmes Co., Mississippi, on the 3rd of last month. The nature of the improvement consists in placing a driving wheel on the outer end of a bar, the inner end of which turns on a pivot shaft. The horse is attached as shown in the figure, at *d*, and the driving wheel gives motion to a vertical shaft through gearing, and a horizontal shaft.

A is a bar the inner end of which is strapped to and turns on a pivot in the socket, G. On the outer end of A, the large broad wheel, H, is secured, and rotates on a journal of the shaft, A. It rests and rolls upon the ground. It has cogs, *c*, on its inner periphery, and these gear with a small pinion, C, on the outer end of the small shaft, B, which is supported and

FULTZ'S HORSE POWER.

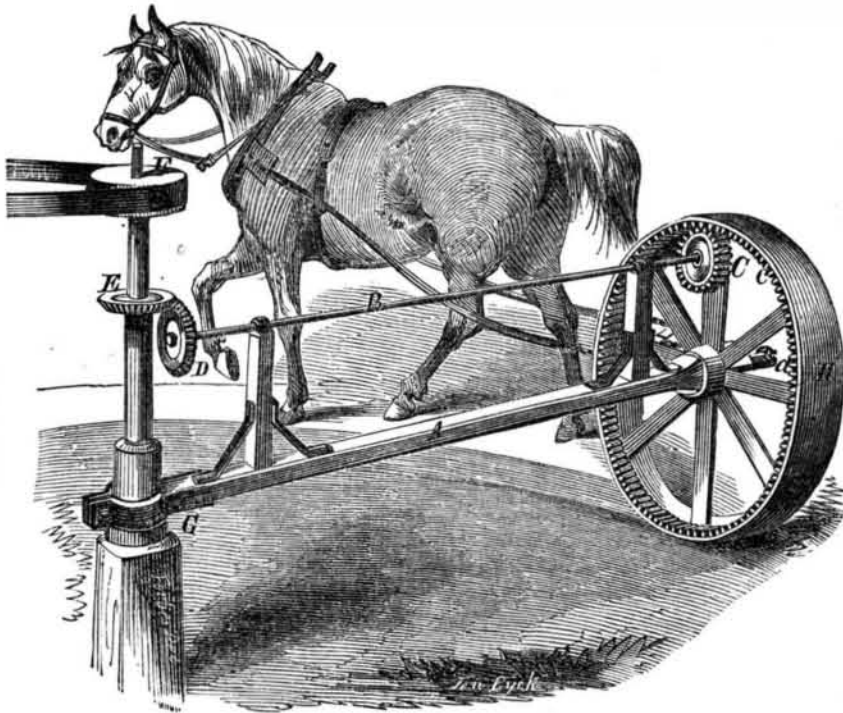

rotates in bearings on uprights secured to bar A. D is a bevel wheel on the inner end of shaft, B, and E is a bevel pinion on a stout vertical shaft supported in the pivot post that sustains the bar, A. F is a pulley on said shaft from which the power is taken by a band to drive other machinery, such as cotton gins, presses, thrashing machines, &c. The horse being attached as represented, the driving wheel, H, rotates, and the shaft, B, drives pinion D, which takes into the pinion, E, giving a rapid motion to its vertical shaft, thus operating the driving pulley, F, from which power is taken to drive other machinery by a belt.

This horse power is very simple to make and run at a good high speed. It can also be constructed very cheaply. One of these has been

used for a considerable time by the patentee, for driving a cotton saw gin of fifty saws, and it works admirably. Any mechanic of ordinary ability may construct such a horse power if he can obtain the castings for the wheels; if not, these may be made of wood boiled in oil. The figure tells the whole story, and requires no further description to render it any clearer to the reader.

For Southern and Western localities, where cheapness of construction, simplicity of management, and effectiveness of operation is wanted, this power will come into extensive use. It is one of the latest novelties in its class.

More information may be obtained by letter addressed to Mr. Fultz, at his residence above named.

HOLMES'S PATENT CAPSTAN.

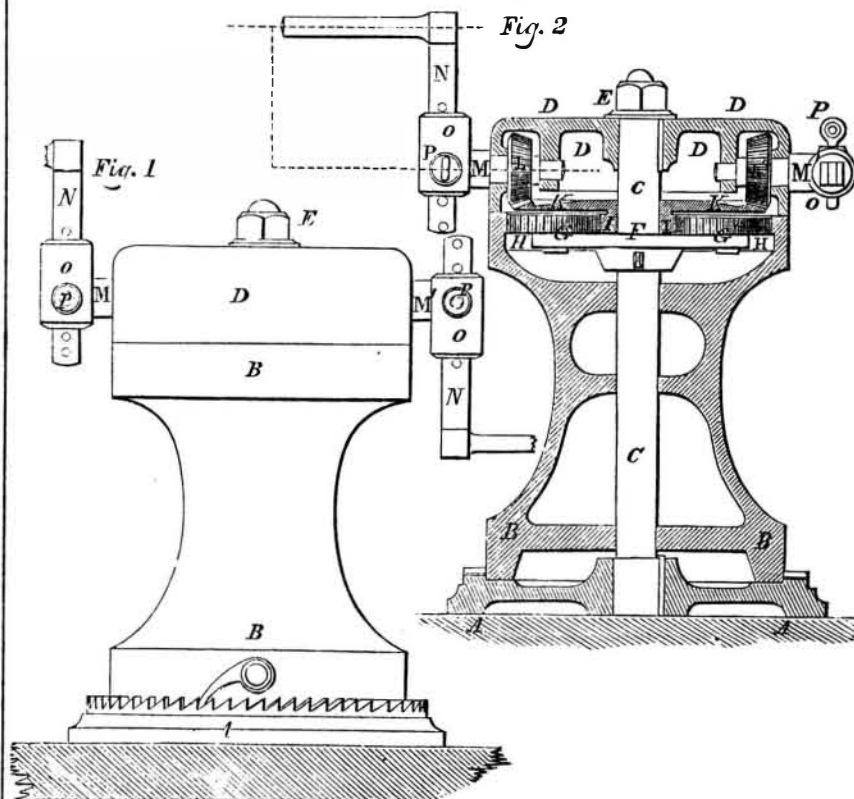

The accompanying engravings are views of an improvement in Capstans, for which a patent was granted to John B. Holmes, of this city, on the 7th of last month.

Figure 1 is a side elevation of the capstan, and fig. 2 is a longitudinal vertical section,

showing the interior. Similar letters refer to like parts.

The nature of the invention consists in the arrangement of a stationary drum head in combination with a stationary base and spindle and revolving rope barrel or body, said barrel

being moved by gearing and cranks.

A is the bottom part or bed plate of the capstan, and of ordinary construction, secured to the flooring or deck of the vessel: the eye in its center receives the vertical spindle or axis C, made of wrought iron and keyed fast to the bottom plate, A. B B is the cast-iron and hollow barrel of the capstan, revolving freely upon the center shaft, C. D D represents the hollow top or drum head; it is also made firm and stationary with the spindle, C, and kept in the proper proximity to B, by means of the top nut, E, thereby allowing the barrel to move closely between the bed plate, A, and the top, D. F is a round plate, firmly secured to the spindle, C, and placed in a proper position to form the support, and the fixed centers for the two spur wheels, G G', these wheels are alternately in gear, with the toothed rim, H H, fig. 2, of the barrel. B B, and in the same time with a third wheel or pinion, I I. This pinion also forms one piece with the large bevel, K K, and both of them are made to revolve loosely upon the fixed spindle, C, maintaining their respective positions to G G'. The hollow top or drum head, D D, contains the bearings for the two shafts, M M', which carry in the interior of the head the two pinions, L L', gearing both into the bevel wheel, K, whilst the other extremities of the shafts project through the top of the capstan, for the purpose of receiving the cranks, N N, then by turning the cranks, proper motions are imparted to the wheel, K, with its pinion, I, and by means of the intermediate wheels, G G', to the barrel, B. The shafts, M M', are provided with cast-iron sockets, O O, arranged so as to allow the crank, N N, to slide through them for the purpose of varying the throw of the latter, as set forth; eye bolts, P P, being provided in the sockets, to keep them in the proper position, when once set and adjusted.

In the use of the common capstan, the men are obliged to jump over the cable or chain, as they walk around with the levers. This very serious objection is wholly done away with in the present improvement, while a compact, convenient and effective capstan is furnished, the expense of which, considering its increased utility, is small.

For more information address the assignee of the patent, J. R. Pratt, No. 62 Attorney st., this city.

Rapacious Claims of Patentees.

Some patentees having discovered one process, set up claims to all others which produce the like results. Their object is to shut off opposition to their interests, and they have not the candor to admit the just claims of after inventors in the same line, when these interfere with their profits, although the inventions may be very different. This spirit has caused more patent litigation in our country than any other. The greatest law-suits have been between contending patentees in the same line of business. The recent decisions of the Supreme Court, U. S., on the Morse Telegraph and the Woodworth Planing Machines, have greatly rebuked this exacting and encroaching spirit. It is to be regretted that so much patent litigation has resulted from the rapacity of some men in obtaining re-issued patents embracing new claims, not embraced in nor discovered when their original patents were taken out, and if encouraged by the courts, it will tend to deter improvement and invention, and defeat the very purpose of the law established to "encourage discovery and improvement" in the arts, by granting patents to each for his own improvement. *

The pressure of the wind increases according to the square of the velocity. It amounts to 12 1-2 lbs. on the square foot in a storm moving at the rate of 50 miles per hour, and 50 lbs. on the square foot in gale of 100 miles per hour velocity.