

New Inventions.

Shaving and FellyCutting Machine

The accompanying engravings represent an improved machine for cutting fellies, and also for shaving wood into fine slivers, &c., for which a patent was granted to S. R. Smith, and Elijah Cowles, of Amherst, Mass., on the 20th of February last. The improvements in this machine relate to the peculiar means employed for giving the necessary feed motion to the cutters; also the arrangement and construction of the cutter head and guide, by which the cutters are made to pass over the stuff to be cut.

Figure 1 is a plan or top view of the machine; figure 2 is a side view of the same, the right side of the frame being removed. Similar letters refer to like parts.

A represents the frame of the machine; B represents a vertical shaft at the back end of the frame, A, said shaft working in a suitable bearing, a. The lower end of the shaft, B, works in a step, b, attached to the upper part of a spring, C. This shaft has two pulleys, D E; D a working, and E is an idle pulley. The working one, D, is attached to a hollow shaft, F, which fits over the shaft, B, and is secured to it by a feather and groove, so as to allow the shaft, B, to rotate when the pulley, D, rotates, and at the same time allow the shaft, B, to be depressed, without depressing the pulley, D. The idle pulley, E, is merely fitted loosely on the hollow shaft, F. The lower part of the shaft, B, has a series of grooves or recesses, c, cut in it, and in these recesses a segment rack, G, gears, said rack being at the end of a lever, H, which has its fulcrum at d. To the outer end of the lever, H, there is attached a weight, I, and also a cord, e, passing over a pulley, f, at the upper part of the frame, A, and having its end secured to a clutch, g, which is on a small shaft, J, the bearings, h, of which are attached to the back end of the frame. On the shaft, J, there is a worm wheel, K, which gears into a screw, L, on the hollow shaft, F, of the pulley, D; M is a lever having its fulcrum at i, one end of this lever is underneath the spring, C, and the opposite end is underneath slide N, attached to the front end of the frame. O is a lever having its fulcrum at j, one end of this lever (the outer end) passes through an upright arm, P, having an inclined or bevelled edge at one end, and the opposite end is fitted in a notch, or underneath a projection on a plate attached to the front end of the frame, A, directly above the slide, N. The outer end of the lever, O, is provided with a wire, m, having a loop in it through which a belt, n, passes, said belt passing around the working pulley, D, and also a driving pulley, R, at the front end of the frame, A. A' is a spring which bears upon the lever, O; S is a slide through which the upright arm, P, passes. The inner end of this slide is attached to the clutch, g. T is a cap which is fitted on the upper end of the shaft, B, and secured thereon by a screw, o. This cap has a flat metal plate, p, secured to its upper surface, and the edges or sides of this plate are bent upwards, as shown in figure 2; n is a plate formed precisely similar to the plate, p, only inverted and placed directly over the plate, p. The two plates being secured together by bolts, q; V are rectangular bars which are fitted between the plates, p, and u, said bars having racks, r, cut in their sides, in which pinions, s, gear, said pinions being upon small upright shafts secured between the plates, p and u, the upper ends of the pinion shafts are provided with cranks, W; x is a sliding stock which works on the outer end of one of the bars, V, one stock only is shown, but in practice each bar is provided with one. The stock, x, near its outer end is provided with a cutter formed of a chisel slightly inclined from a horizontal position, and a series of cutting points, three or more, directly behind it. Near the inner end of the stock, x, there is an arm, w, which projects downwards, and has a slot, x, cut in its end. Y is a disk secured on the upper part of the frame, A, and having an upright rim or ledge, y, around it. This disk is of nearly,

but not quite, circular form, one side being curved or bent, as shown at z, figure 1.—The rim or ledge, y, fits in the slot in the lower end of the arm, w, as shown in figure 2.

OPERATION—Motion being given the driving pulley, R, the pulley, D, is made to rotate, and also the shaft, B, with the bars, V V. Each bar, V, being provided with a stock, X, and cutter attached to it. The cutter, as the bars, V, rotate, passes in a right or straight line over the "stuff," which is

placed on the upper part of the frame, A, and represented by a'. The cutters pass over the stuff in a straight line, owing to the irregular curved portion, z, of the rim or ledge, y, said portion, z, operating or moving the cutter stock, X, in consequence of the arm, w, fitting on or over the rim or ledge, y. The cutters as they pass over the stuff, cut thin narrow shavings, the chisel, u, cutting a broad shaving, and the small cutters dividing it into narrow ones. The cut-

SHAVING, AND FELLY CUTTING MACHINE.

Fig. 1

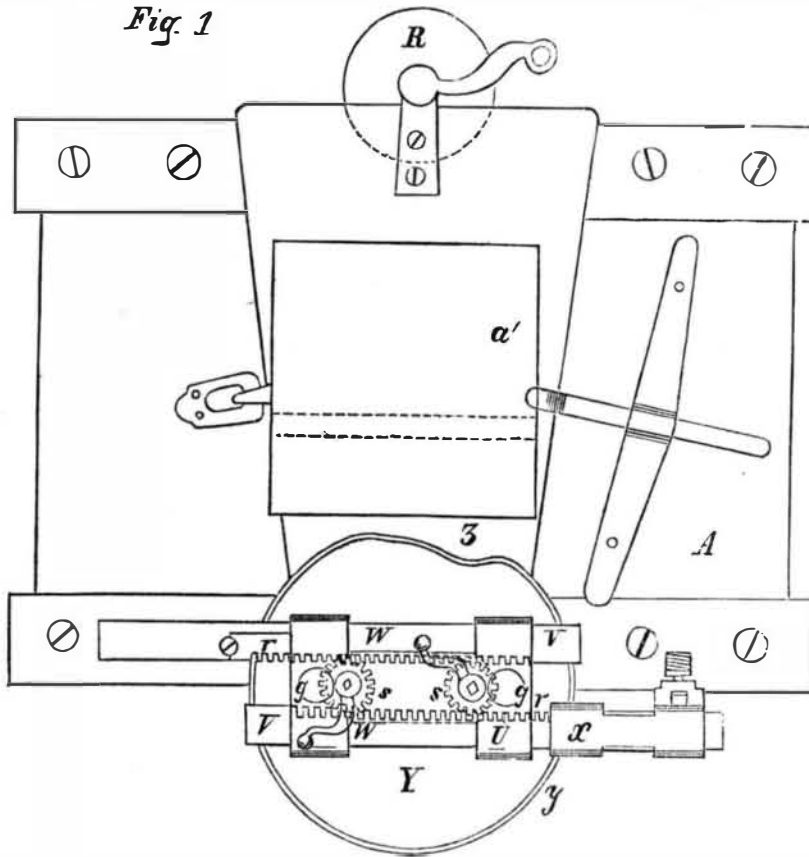

ters are fed down upon the stuff in the following manner:—As the hollow shaft, F, rotates, the screw, L, upon it communicates motion to the worm-wheel, K, and the small shaft, J, rotates, and the cord, e, is wound upon the one part of the clutch, g, the weighted end of the lever, H, is consequently raised, and the inner end depressed, and as the rack, G, gears into the recesses, c, the shaft B, is gradually depressed, and the cut-

ters fed to the stuff. When the cutters have descended a distance equal to the thickness of the stuff, the spring, C, is depressed sufficiently to cause the inner end of the lever, M, to act upon the slide, N, and throw the inner end of the lever, O, out from underneath its catch, and the spring, A', throws the inner end of the lever, O, upward, and the upright arm, P, in moving, throws the slide, S, in such manner as to separate or

Fig. 2

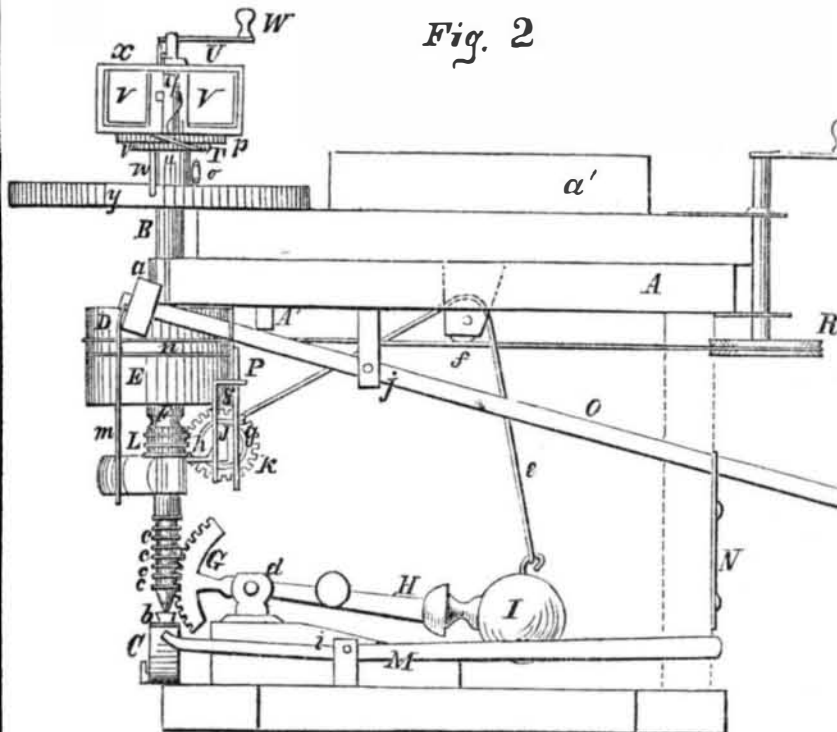

disconnect the clutch, g, and consequently the feed motion ceases, the shaft, B, and lever, H, returning to their original position, by means of the spring, C, and weight, I, the belt, n, by the downward movement of the lever, O, being thrown on the idle pulley, E. The cutters are then moved outward so as to take another cut by turning the cranks, W. The inner end of lever, O, is placed under its catch, and the operation above described is repeated. It is necessary that the cutters should pass in a straight line over the stuff in order that the shavings may be

cut in the direction of the grain, and not transversely with it; in the latter case the shavings would be brittle and have no elasticity.

Messrs. Smith and Cowles have applied this machine to cutting out fellies, which gives great satisfaction, but as a shaving machine, to make fine shavings for upholstering and other purposes, it stands without a competitor.

More information may be obtained by letter addressed to the patentees, at Amherst, Mass.

Improved Support for Articles of Dress.

On the 13th of last month, John Dick, of this city, obtained a patent for an improvement in stays for articles of wearing apparel, the claim of which was published on page 190.

Figure 1 is an edge view of the improved stay or supporter, and fig. 2 shows its application to the leg of a boot. This supporter is composed of two or more supporting pieces of whalebone, rattan, steel, or any other suitable material, with a spring applied to them in such a way as tends to keep them extended lengthwise. It is applied to such part of a garment (or article of dress, like fig. 2) as is liable to become wrinkled by the movements of the body, or otherwise, for the purpose of keeping such part in proper shape, and also bringing it back to proper shape when contracted by the motions of the body. The supporter represented is composed of two supporting pieces of whalebone, a a', and one spring, b, composed of a strip of india rubber webbing. One end of the spring is connected by sewing or lacing to the upper end of a. This supporter is placed and secured in a garment in the same manner as whalebone strips in corsets, or on the waists of frocks, care being taken to have it well secured at the ends, and to have it a little contracted, so that the spring will have some tension upon it. By applying this supporter to the legs of boots, these can be made of canvas or woven cloth, which is much cheaper, and in some respects better than leather, but which, without being stayed or supported, is unfit to be so applied, as it will not stand up. Even leather boots fall down into wrinkles, and are greatly improved by this kind of staying to prevent creasing, and thus make pantaloons sit neat upon them.

Fig. 1

Fig. 2

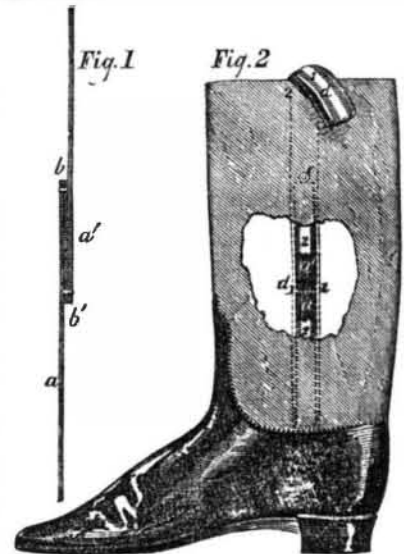

To apply this supporter to a boot, the straps, d, are extended double all the way down the interior of the leg, and the supporter is placed between the inner part, 1, and the outer part, 2, of the strap, confining it at the ends and edges by stitching 1 and 2 together, or by eyelet fastening, e. These straps require to be secured to the boot at their lower end and near the top, by stitching, as shown by the dotted lines.

This useful improvement may be applied to all parts of ladies' dresses for which whalebone is now employed. It can also be applied to the bottom of the legs of pantaloons, to keep them in proper shape; indeed, it is applicable to a great many articles of dress.

More information may be obtained by letter or otherwise, of Mr. Dick, at 405 Broadway, this city.

Safety Ferry Bridge.

The invention for which a patent was granted, in our list of last week, to Henry Lawrence, of this city, is designed to prevent persons and vehicles passing over the edge of the floating bridge, after a boat has started, by which many lives are lost in this city every year. A gate is provided on the bridge, and hung in such a manner that when the boat comes in and strikes the bridge, the gate swings and opens to allow passengers and vehicles to pass into and out of the boat, but which, when the boat leaves, immediately closes automatically.