

THE MAGNETO-ELECTRIC DISK TELEGRAPH.

[Translated for the Scientific American.]

Messrs. Siemens & Halske are the proprietors of a large manufactory of telegraphic instruments in Berlin, Prussia, and the instrument which we are about to describe is rendered prominent by its compactness, and by its surety and rapidity of operation, whereby it is particularly adapted for railroads. Three hundred of these instruments are already in use on the different railroad lines in Bavaria alone.

The construction of this instrument will be easily understood by the aid of the accompanying engravings, in which Fig. 1 represents a transverse vertical section of this instrument; Fig. 2 is an enlarged view of the coil and its appendages for the purpose of moving the index; Fig. 3 is a sectional plan of the electro-magnetic coil which produces the opposing currents necessary to propel the index; and Fig. 4 is a transverse vertical section of the same.

The poles of an electro-magnet, A, which is reversible in its integument, are placed between the opposite poles of two steel magnets, B B'. These steel magnets are arranged on a carriage, C, and they are adjusted so that both exert an attraction of equal power on the electro-magnet, which takes the place of the armature. To the reversible electro-magnet, an arm, D, is screwed, from which two prongs, *d d'*, extend, that are furnished with spring hooks, *e e'*. These hooks engage with the teeth of a small ratchet-wheel, *f*, which is turned for one tooth by each backward or forward motion of the lever, D.

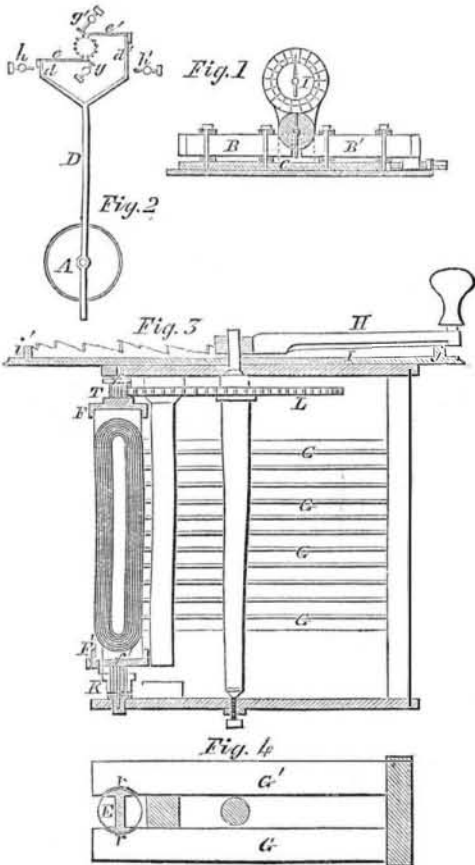

The hooks, *e e'*, are furnished with projections extending beyond the wheel, and bent down, which strike against screws, *g g'*, whenever the motion of the arm, by coming in contact with the set-screws, *h h'*, has arrived on its extreme point. By these means, the progress of the wheel beyond the required distance is prevented.

The axle of the ratchet-wheel, *f*, bears the index.

If, now, a current passes through the coil of the electro-magnet, its poles are attracted by one and repelled by the other of the electro-magnets, and the wheel, *f*, is turned for one tooth. If, now, a current passes through in the opposite direction, the attraction and repulsion is reversed, and the second motion of the wheel is effected, and so on.

The opposing currents of equal intensity necessary to propel the index are produced by a magnetic-inductor, which is represented separately in Figs. 3 and 4, and the construction of which differs considerably from those now in use.

This inductor consists of an iron cylinder, E, provided with a groove of about 7-16 of the diameter in depth, and

2-3 of the diameter in width, and extending in a longitudinal direction all round the cylinder, as clearly shown in Fig. 3. This groove is filled up with braided copper-wire, in such a manner that the cylindrical form of the iron, E, is restored.

Secured to the ends of this cylinder are the boxes, F F', with the pivots, *f f'*, which latter form the journals for the cylinder, E.

Said cylinder rotates between the poles of a number of small steel magnets, G G', placed in pairs, one above and at a short distance from the other, as clearly shown in Fig. 4.

Said steel magnets are formed of magnetic steel rods, and segmental recesses, *r*, are cut out of their front ends, exactly opposite to the cylinder, E, and nearly filled up by the same, and their rear ends are united by horse-shoe-shaped rods of soft iron. From this, it will be seen that the cylinder, E, forms the common armature for the several steel magnets, G G', and if said cylinder is rotated, the magnetism in the inner flat iron core is reversed for every half revolution; and, whenever this takes place, a current is produced, the intensity of which is in direct ratio with the quantity of magnetism confined in said core. The successive currents run alternately in one and in the other direction, and their magnetic value is exactly alike.

The cylinder, E, is rotated by means of a cog-wheel, L, which goes into a pinion, T. A crank, H, is mounted on the arbor of the cog-wheel, L, and said crank rotates on the face of the dial-plate, I, which is marked with the letters and figures of the telegraph. The handle of this crank can be depressed by a slight exertion of the hand, and a nose secured to its under side catches into recesses, *i i'*, on the edge of the dial-plate, whereby the wheel, L, and the cylinder, E, is arrested.

The ends of the helix of the cylinder, E, communicate with one end of the helix of the appertaining telegraphing instrument (the other end of this helix communicates with the line wire), and with the earth.

The indexes of the telegraphs thus inserted on two stations rotate, therefore, with every half revolution of the cylinder, E, for one tooth.

When the cylinder, E, is at rest, a contact, K, closes the circuit of the helix on this cylinder; so that the arriving current cannot pass through it before said contact is removed.

The advantages of this inductor over others now in use, are:—

First, That it gives only two currents in opposite directions, and of perfectly equal intensity, for every revolution of the cylinder; whereas, all the inductors as now used, produce four separate currents—one in removing one of the iron poles from one of the magnet-poles; a second one in the same direction when the iron approaches the opposite pole of the magnet; a third in the opposite direction, by removing the iron from this pole; and a fourth in the same direction of the third current, when the iron approaches the first pole of the magnet.

Second, The inertia of the rotary cylinder is only about 1-20 of that of similar cylinders used in the usual manner. For this reason, it is easy to effect the rotation by hand, as described, or by a running-gear, without any extra power, if it is preferred to use a series of keys for arresting the same.

Third, Instead of two large magnets, an indefinite number of small magnets can be employed. And, as the power of steel magnets is as the square root of their weights, a much more intensive current is obtained with an equal weight of steel by using the above-described inductor. From this it will be seen that not only a great amount of steel is saved, but the intensity of the current can be increased at pleasure, and at a comparatively small expense.—*Dingler's Polytechnic Journal*.

LACASSAGNE & THIERS' DRY GALVANIC BATTERY.

[Translated for the Scientific American.]

This battery is, for itself, or in combination with other elements, a powerful source of electricity. One part of the elements is employed to produce a metal which not only covers the cost of the battery, but which contains another advantage arising from the decomposition of the substances used for charging the battery.

A vertical central section of this apparatus is represented in Fig. 1, and Fig. 2 is a plan of the same.

The battery consists of a vessel, A, of fire-proof clay. Into this vessel an iron cylinder, B, is placed, which is open on both ends, and to which a conducting-wire, G, is attached. In the interior of this cylinder, there is a diaphragm, C, of clay, which receives a rod, H, of gold, platina or charcoal, to which the other conducting-wire, E, is attached.

The exciting medium consists of common salt, which is placed into the outer vessel, and chloride of aluminium or chloride of manganese; free of water, which is put into the inner diaphragm of clay. This battery is heated in a common stove to a red heat. The chloride of soda excites the positive metal, B; the chloride of aluminium the negative element, H. If both the salts are red-hot, and if the conducting-wires are now united, an electric current is produced, which turns a piece of soft iron, inserted between the currents, into a powerful electro-magnet.

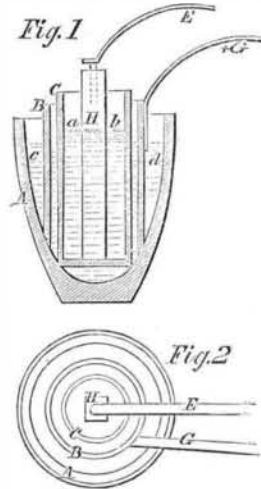

The metal, B, is eaten up by the corrosive power of the common salt, and the chloride of aluminium is decomposed into chlorine (which escapes) and into aluminium, which collects on the bottom of the diaphragm, C. It is obvious that a number of such batteries may be united and a current may be formed of sufficient power for any practical purpose, and, at the same time, a quantity of aluminium is obtained. In order to effect the positive element more rapidly, a small amount of nitrate of potash or chloride of potash may be added to the chloride of soda.—*Armstrong's Genie Industriel*.

MILK WHICH DOES NOT YIELD BUTTER, AND THE MEANS TO REMEDY IT.

M. Deneubourg addresses those who are chiefly interested in cases in which there is no disease of the mammary gland nor loss of milk, but a want of oleaginous matters in the fluid. In the causes of this deficiency of butter-making quality, he concludes that there are two principal ones, viz.: idiosyncrasy and alimentation; but there is another which cannot be so easily defined, and which occurs in animals that are well kept, and whose milk has been previously rich in butter. It is to these that the remedy is principally directed. The remedy consists in giving the animal two ounces of the sulphuret of antimony, with three ounces of coriander seeds, powdered and well mixed. This is to be given as a soft bolus, and followed by a draught composed of half a pint of vinegar, a pint of water, and a handful of common salt, for three successive mornings, on an empty stomach.

The remedy, according to the author, rarely fails, and the milk produced some days after its exhibition is found to be richer in cream. The first churning yields a larger quantity of butter, but the second and the third are still more satisfactory in their results.

A letter from a farmer states that he had fourteen cows in full milk, from which he obtained very little butter, and that of a bad quality. Guided by the statements of M. Deneubourg, which had appeared in the *Annales Veterinaires*, he had separately tested the milk of his cows, and found that the bad quality of it was owing to one cow only, and that the milk of the others yielded good and abundant butter. It was, therefore, clearly established that the loss he had so long sustained was to be attributed to this cow only. He at once administered the remedy recommended by M. Deneubourg, which effected a cure.—*Veterinarian*.