

**QUIMBY'S MONITOR CLOCK.**

This device is designed particularly for the use of schools. Its object is to enable the teacher so to arrange the clock as to indicate, by the stroke of a hammer upon a bell, the time for commencing and closing each recitation.

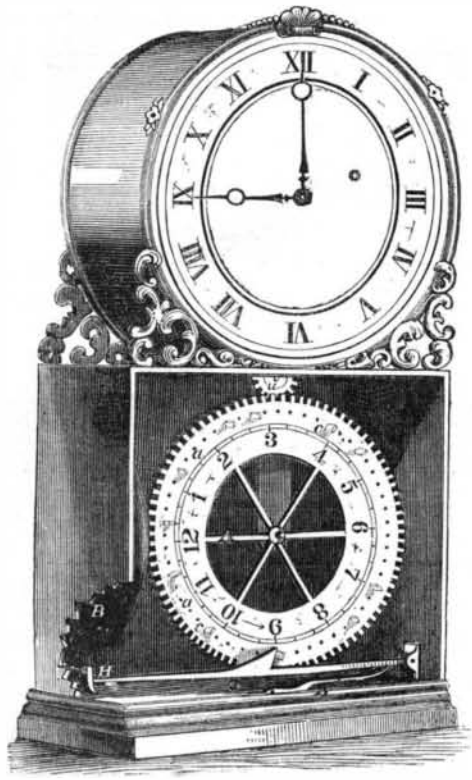

The engraving represents a perspective view of this invention. The wheel, A, is so connected with the clock-work by the gear, u, that it (the wheel) revolves once in every 12 hours in the direction of the arrow marked upon it. In this wheel are drilled 144 holes, a a, which receive the pins, c, which are so arranged that they can be inserted or removed at pleasure. Some of these pins are represented in their place. Each pin, as it passes the cam, C, causes the hammer, H, to strike, by means of the spring, S, upon the bell, B. Thus, by inserting the pins at the proper intervals, as indicated by the figures on the wheel, A, the time of each recitation may be indicated, however irregular those intervals may be. When all the pins are in their place, the hammer will strike once in five minutes. If every other pin is removed, the hammer will strike once in 10 minutes, and so on; and it will easily be understood how the hammer may be caused to strike at different and still shorter intervals by increasing the speed of the wheel, A, or the number of the pins, c.

Those who appreciate the importance of promptitude and regularity in the school-room will readily see the utility of a monitor so vigilant and incorruptible. But this device may also be used for railroad-stations, and for other purposes where irregular portions of time are required to be audibly indicated. This invention was patented June 14, 1859, by E. T. Quimby, of New Ipswich, N. H., and further information of the same will be furnished by addressing Newton Brooks, of the same place.

**IMPROVED CAST STEEL.**

In a communication to the London *Engineer*, Mr. Robert Mushet, in commenting upon the "Bessemer process" for manufacturing iron, describes improvements which he has made in producing steel from cast-iron. In an experiment with Welsh No. 1 pig-iron, which was purified in a Bessemer furnace, he added 10 pounds of a triple compound of malleable iron, carbon and manganese, to every 70 pounds of the cast-iron, and the ingots made from this were good welding cast-steel, on the other hand, ingots made from the same pig metal without the manganese and carbon being added, were so brittle that they cracked to pieces at both a high and low heat when worked under the hammer. He asserts that there never was, or can be, a bar of first-rate cast-steel made by the Bessemer process alone. In all pig-iron there is generally too much phosphorus, sulphur, or oxyd of iron, either of which prevents it from becoming steel. As metallic manganese is about the most oxydizable of metals,

a small portion of it suddenly combined with liquid iron, holding oxyd in solution, takes up the oxyd from the iron, converts it into the oxyd of manganese, which passes into the slag, and in this manner the metal is purified. It is generally held that molten iron cannot contain oxyd of iron in solution, but Mr. Mushet is of a different opinion. He also asserts, that a very small quantity of metallic manganese introduced among molten cast-iron counteracts all the pernicious effects of phosphorus and sulphur in it. He says, "I have merely availed myself of a great metallurgical fact, namely, that the presence of metallic manganese in iron or steel, conferred upon both an amount of toughness, when cold and heated, which the pressure of a notable amount of sulphur or phosphorus cannot overcome." In another portion of his letter he says, "The great remedy for red-shortness in iron or steel is simply the addition of a little metallic manganese thereto. Why are the Prussian irons celebrated for their excessive red-toughness and cold-toughness? Simply because they contain a small alloy of metallic manganese."

Here is information for our iron manufacturers who are endeavoring (or those who may wish to engage in the business) to make steel from pig-iron. Metallic manganese combined with cast-iron in a crucible converts it into good steel, according to Mr. Mushet's statement, and he has received a patent in England for the invention. It must not be forgotten that it is not the oxyd of the manganese which is usually employed in making steel, but the metal itself which is used. And it will not do to mix it with the pig-iron in the smelting furnace, because in that case, the manganese will all be oxydized by the air, instead of taking up the oxyd from the iron to purify it. This is a subject of no small importance, for if a little metallic manganese can convert iron scraps into good cast-steel when smelted in a crucible, every machine-shop in our country may easily manufacture its own steel.

**IMPROVED CAM PRESS.**

Here is a novel idea for a press, which, in the directness with which it multiplies the power, makes a not distant approach to the hydraulic press itself. A brief inspection of the engraving will enable one to understand the nature of the device.

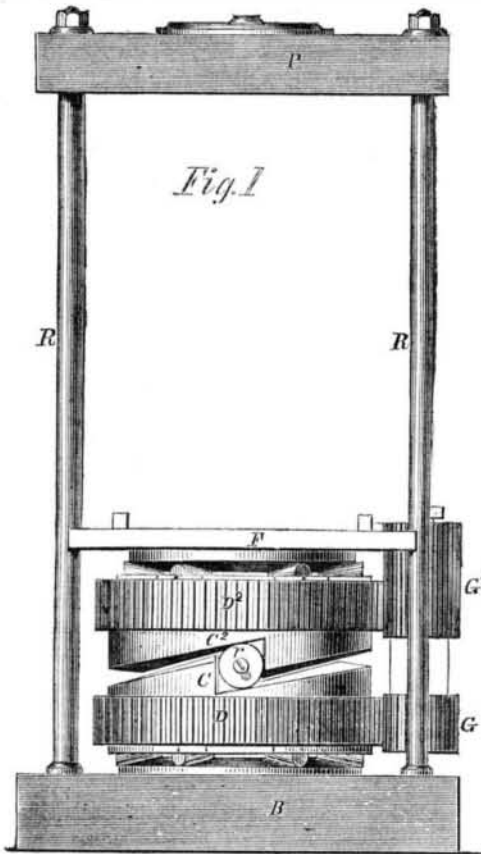

The circular base, B B, is connected with the circular platen, P P, by means of the rods, R R R R. It will be seen that if the upper disk, D2, is made to revolve while the lower disk, D, is held stationary, the upper disk must rise, because it rolls the roller, r, up the inclined cam, C, and its own cam, C2, also presses upon the roller in a way to raise the disk. But in order to increase the power, instead of holding the lower cam stationary, it is caused to revolve only a very little more slowly than

the upper cam. This is effected by having the geared periphery of the upper disk contain one more tooth than the periphery of the lower disk. The disks are made to revolve by turning the gears, G and G2, by means of the lever, L, which works with a click or pawl. Friction-rollers are interposed between the base, B, and the lower disk, and between the upper disk and the follower, F. These rollers, as well as the rollers, r, between the cams, are hung to frames, f f f, which run loosely about the shaft, S. All these rollers are provided with beveled tracks above and below.

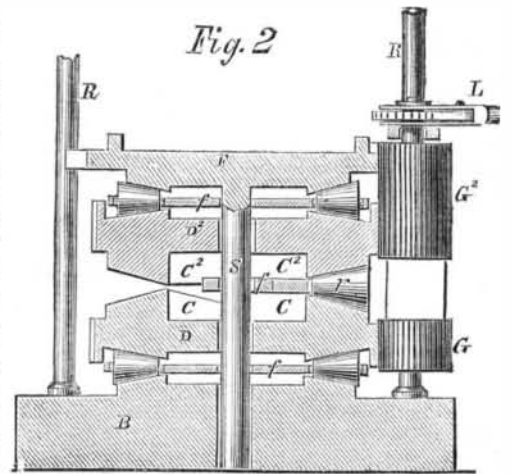

When the press is used as a punch, the punch is attached to the lower end of the shaft, S, the follower is braced in its place, and the upper disk only caused to revolve by means of a crank attached to one of the friction rollers which interpose between it and the follower; the gears, G and G2, in this case being dispensed with.

The patent for this invention was granted to Thomas R. Hopkins, of Petersburg, Va., August 23, 1859.

**MECHANICS, INVENTORS, MILLWRIGHTS, AND MANUFACTURERS.**

The SCIENTIFIC AMERICAN is a paper peculiarly adapted to all persons engaged in these pursuits, while to the Farmer, Housekeeper, and Man-of-Science, it will be found of equal interest and use.

The SCIENTIFIC AMERICAN has been published FOURTEEN YEARS, and has the largest circulation of any journal of its class in the world. It is indispensable to the Inventor and Patentee; each number containing a complete official list of the claims of all the patents issued each week at the United States Patent Office, besides elaborate notices of the most important inventions, many of which are accompanied with engravings executed in the highest degree of perfection.

To the Mechanic and Manufacturer the SCIENTIFIC AMERICAN is important, as every number treats of matters pertaining to their business, and as often as may be deemed necessary a column or two on the metal and lumber markets will be given; thus comprising, in a useful, practical, scientific paper, a Price Current which can be relied upon.

The SCIENTIFIC AMERICAN is published weekly, in a form suitable for binding, each number containing sixteen pages of letter-press, with numerous illustrations, making a yearly volume of 832 pages of useful matter not contained in any other paper.

**Terms.**

Two volumes will be issued each year; but there will be no CHANGE IN THE TERMS OF SUBSCRIPTION, as the two yearly volumes together will be Two Dollars a Year, or One Dollar for Six Months.

**Club Rates.**

Five Copies, for Six Months.....	\$4
Ten Copies, for Six Months.....	\$8
Ten Copies, for Twelve Months.....	\$15
Fifteen Copies, for Twelve Months.....	\$22
Twenty Copies, for Twelve Months.....	\$28

For all clubs of Twenty and over, the yearly subscription is only \$1 40. Names can be sent in at different times and from different Post-offices. Specimen copies will be sent gratis to any part of the country.

Southern, Western, and Canadian money or Post-office stamps taken at par for subscriptions. Canadian subscribers will please to remit twenty-six cents extra on each year's subscription to pre-pay postage.

When persons order the SCIENTIFIC AMERICAN they should be careful to give the name of the Post-office, County, and State to which they wish the paper sent. And when they change their residence, and wish their paper changed accordingly, they should state the name of the Post-office where they have been receiving it and that where they wish it sent in future.

**Rates of Advertising.**

Thirty cents per-line for each and every insertion, payable in advance. To enable all to understand how to calculate the amount they must send when they wish advertisements published, we will explain that ten words average one line. Engravings will not be admitted into our advertising columns; and, as heretofore, the publishers reserve to themselves the right to reject any advertisement sent for publication.

MUNN & CO.  
Publishers, No. 37 Park-row, New York.